

VIVONET

Vivonet POS Validated Integration with Oracle Hospitality OPERA 5.5

A point of sale (POS) to property management system (PMS) integration made simple.



Suite 1790
1188 West Georgia Street
Vancouver BC V6E4A2
Canada
Tel.: +1.604.215.2033
vivonet.com

The Vivonet Cloud POS platform is a completely configurable, enterprise-grade solution that offers hotels a seamless connection to their organization.

Company Overview

Vivonet is a leading provider of consumer, operational, and enterprise technology solutions for the hospitality industry. Through its cloud-based platform, Vivonet delivers insights and intelligence to businesses, enabling them to increase revenues, reduce costs, and improve overall organizational performance.

Integration Overview

Vivonet POS terminals integrate to Oracle Hospitality OPERA PMS through a custom PMS gateway. POS terminals are integrated with the PMS gateway via a REST API; then, the PMS gateway is integrated with Oracle Hospitality OPERA PMS via TCP socket. Functionality supported includes posting charges to rooms and doing a room inquiry to confirm a guest is registered to a room. The integration also supports itemizers on the revenue center level.

Integration Details

This integration includes operational and administrative functionality. Operational features include enabling food and beverage employees to:

- Post charges to a guest room on their behalf.
- Post a charge to multiple guests in the same room.
- Do an inquiry by room number to confirm a guest is registered to a room.
- Do an inquiry by guest's last name to find a room number.
- Swipe a room card on the POS to post a charge to a guest's room.

Administrative functionality includes:

- Support for up to 16 itemizer categories.
- Option to send all POS transaction data to Oracle Hospitality OPERA PMS.



Validated Integration

Oracle Hospitality

Oracle Validated Integration provides customers with confidence that a partner's integration with an Oracle on-premises application is functionally sound and performs as designed. This can help customers reduce deployment risk, lower total cost of ownership, and improve the user experience related to the partner's integrated offering.

AVAILABILITY

For additional information about Vivonet’s consumer, operational, and enterprise solutions, contact

Tel.: 1.866.512.2033
 Email: sales@vivonet.com

SUPPORT

For technical support, contact
 Tel.: 1.888.778.4256
 Email: support@vivonet.com

The PMS gateway is a custom component enabling Oracle Hospitality OPERA PMS to communicate with multiple POS terminals. The connector between the PMS gateway and Oracle Hospitality OPERA PMS was developed according to the Oracle Hospitality PMS Interface . The PMS gateway exposes a REST API that is consumed by POS terminals to send requests to Oracle Hospitality OPERA PMS.

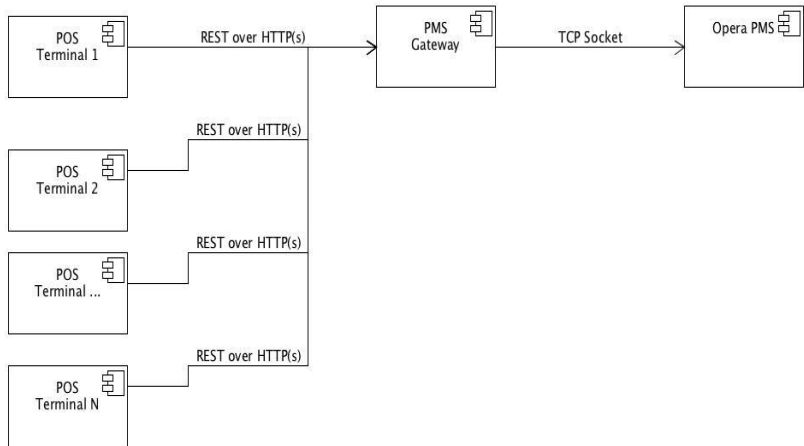

Figure 1. Integration architecture between Vivonet POS and Oracle Hospitality OPERA

Technical Details

Environment	
Partner Environment	Oracle Environment
<ul style="list-style-type: none"> Vivonet POS 3.0.10 and above 	<ul style="list-style-type: none"> Oracle Hospitality OPERA 5.5 Oracle Hospitality Interface IFC8 8.10.1.10
Product ID	
Product ID (FKT)	Description and Name
<ul style="list-style-type: none"> IFC_VIV 	<ul style="list-style-type: none"> Oracle Hospitality OPERA POS for Vivonet POS - Vivonet Acquisition, Ltd
Supported Protocol/TCP-Socket Connection	
<ul style="list-style-type: none"> Direct Socket Connection 	