

ORACLE
OPTIMIZED SOLUTIONS

An Oracle Technical White Paper
January 2013

Implementation Guide for Highly Available SAP on Oracle SPARC SuperCluster

Based on the Oracle Optimized Solution for SAP

ORACLE

About this Document	2
Introduction	3
Solution Layout Overview	3
Highly Available Architecture	4
Oracle Solaris Cluster Setup	5
Step 1. Configuring Hostnames Resolution	5
Step 2. Quorum device iSCSI LUN and NFS file systems	7
Step 3. Oracle Solaris Cluster installation	10
Step 4. Configuring the Oracle Solaris 10 GP domains into a cluster.....	13
Initial Zone Cluster Setup	16
Step 5. Creation of the zone clusters for SAP	16
Step 6. Preparing the zone cluster environment	23
Step 7. SPARC SuperCluster specific tuning	23
Step 8. Creating initial resource groups and logical host resources	23
Step 9. Preparing the NFS file systems for Zone Clusters.....	25
Step 10. Configuring the plug-in for Oracle Solaris Cluster fencing and creating storage resources	28
SAP Setup.....	36
Step 11. Installing SAP	36
Step 12. Database Migration to Exadata Storage	92
Step 13. Add RAC VIPs and Listeners on the IPoIB network	103
Step 14. Connect the SAP instances to Oracle RAC	106
Step 15. Move the Connections from 10 GbE to InfiniBand.....	110
Step 16. SAP Resource Creation	111
Final Zone Cluster Setup	121
Step 17. Finalize the Storage Configuration.....	121
Step 18. Configure the Oracle External Proxy resource	121
Step 19. Configure the cross-zone clusters dependencies	122
Step 20. Configure CPU resource control for the zone clusters	123
Step 21. Configure Policy-based Failover	123
References and Documentation	125

About this Document

This document contains best practice examples for the installation and configuration of Highly Available SAP on the Oracle SPARC SuperCluster T4-4 engineered system. Created and validated during the development of the Oracle Optimized Solution for SAP, these step-by-step instructions show how to prepare and configure the infrastructure, including zone clusters, RAC Framework, or creating users and resource groups for SAP.

The examples provided in this document follow and complement the official product documentation and best practices published by SAP and Oracle and do not replace these documents. The References section lists links to recommended additional documentation, whitepapers and best practices related to installing and configuring SAP on a similar infrastructure or its subcomponents.

These instructions apply to a fully functional SPARC SuperCluster system, in good operating condition, with all its components in their default pre-configured states as delivered by Oracle service engineers. The intent of this document is neither to diagnose nor to reconfigure the infrastructure. Contact your Oracle service representative for instructions to fix or reconfigure your Oracle systems if necessary.

For best results, it is recommended to leverage the Oracle Solution Center for SAP and Oracle Advanced Customer Services (ACS) to deploy this solution.

The Oracle Solution Centers provide presales support, including capacity planning, proof of concept (POC) deployments and IT infrastructure optimization, to help customers discover a proven way to architect SAP deployments on Oracle technology. A simple engagement framework provides access to Oracle's state-of-the-art facilities and Oracle and SAP architects, as well as Oracle Database and hardware support teams. With a global presence and facilities located in Santa Clara (California, USA), Walldorf (Germany), and Tokyo (Japan) the Oracle Solution Center team helps IT organizations assess current SAP deployments and achieve optimal results when transitioning to Oracle engineered systems, new Oracle servers, and other Oracle technology. To learn more about Oracle Solutions Center for SAP, visit <http://www.oracle.com/osc>.

Oracle Advanced Customer Services (ACS) are designed to help customers achieve the optimization of SAP on SPARC SuperCluster architectures. Oracle staff members possess deep product knowledge and, together with the Oracle Solution Center for SAP, are used frequently to supply staffing and deliver content for SAP technical events, as well as provide Oracle database and systems related SAP Notes. Offering a full range of services—Install and Configuration Diagnostic Review, Installation Service, Configuration Service, SAP-specific Oracle-to-Oracle (O2O) and Oracle-to-Oracle Online (Triple O) Migrations, Production Support Readiness, and a Patch Deployment Service—Oracle ACS can help IT organizations get SAP landscapes up and running on engineered systems quickly.

Introduction

This document reproduces the steps that were followed by the Oracle engineering team while configuring SPARC SuperCluster and installing SAP during the development of the Oracle Optimized Solution for SAP. Additional architecture details and test results can be found in the Oracle technical white paper “How to Improve the Efficiency and Performance of an SAP Environment with the Oracle Optimized Solution for SAP” available from:

<http://www.oracle.com/us/solutions/oos/sap/overview/index.html>

Solution Layout Overview

For this example, Oracle VM for SPARC was used to divide each SPARC T4-4 server node into two separate domains, the App domain (also called General Purpose domain or GP domain) where SAP is installed and the Database domain (DB domain) running Oracle Database 11g Release 2 and Oracle Real Application Clusters (RAC).

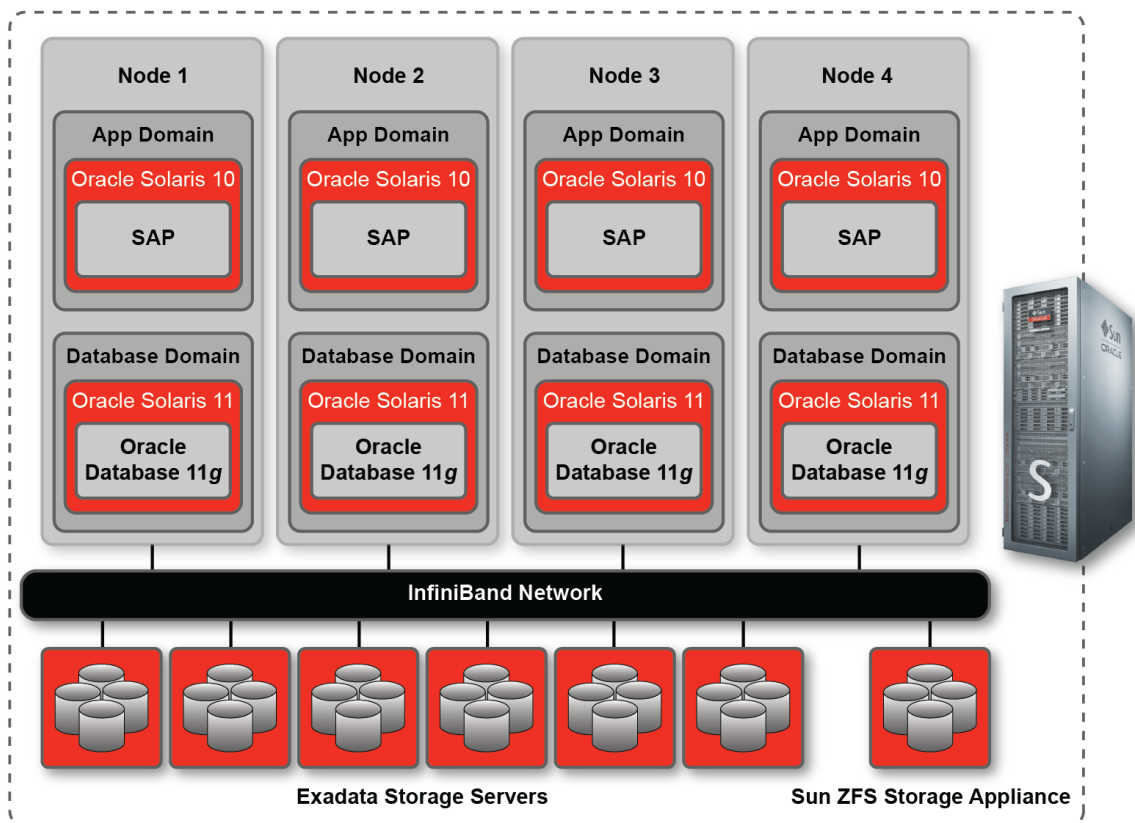

Figure 1. Each SPARC T4-4 node is split in two domains using Oracle VM for SPARC.

Highly Available Architecture

This configuration example is for an ABAP-only SAP system "QO1" with Oracle Database.

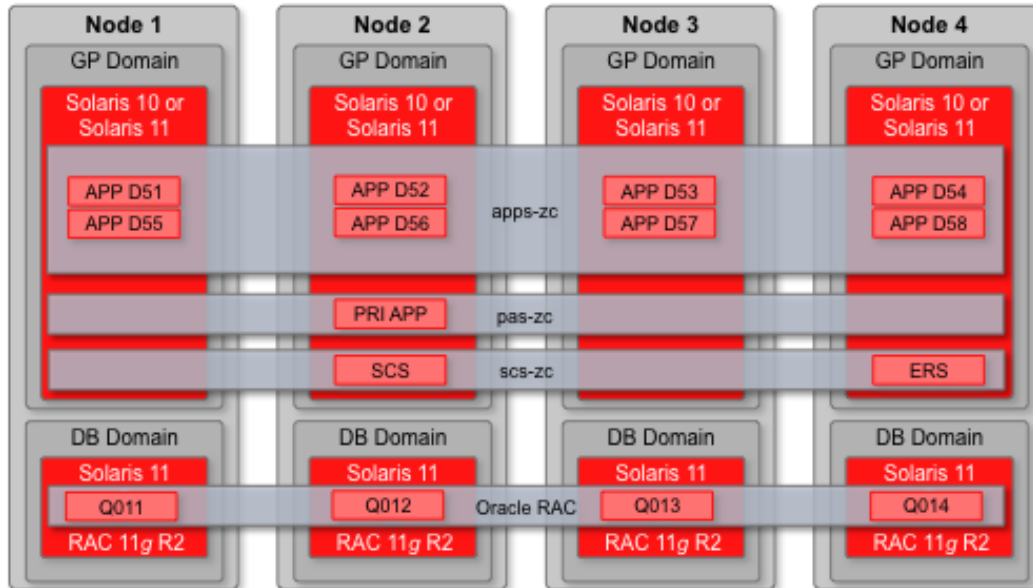

Figure 2. Virtual clusters ensure high availability of critical SAP services.

Oracle Solaris Cluster is leveraged in the GP Domains to ensure maximum availability of the SAP Central Services and of the business-critical application servers. The number of necessary zone clusters will vary depending on the requirements of the implementation. 4 zone clusters were created in our example:

- **<sapdev-zc>** for development and an initial Oracle Database supporting the SAP installation. Not shown in Figure 2 above, as it is not part of the production environment.
- **<scs-zc>** for the ABAP SAP central services (ASCS) and Enqueue Replication Server (ERS).
- **<pas-zc>** for the SAP primary application server instance (PAS for newer SAP releases, or Central Instance for previous SAP releases)
- **<apps-zc>** for 8 SAP application server dialogue instances D51-D58 (AAS for newer SAP releases, or Dialog Instances for previous SAP releases)

All the operations were performed in the Oracle Solaris 10 General Purpose domains, which are also referred to as "nodes" in this document, since they will become Oracle Solaris Cluster nodes.

Note: Although the present example shows an implementation of the application tier in General Purpose domains running Oracle Solaris 10, running Oracle Solaris 11 is also a supported option.

In the DB Domain, Oracle Clusterware is the cluster technology, fully integrated with Oracle Real Application Clusters (RAC).

Oracle Solaris Cluster Setup

Oracle Solaris Cluster extends the Oracle Solaris OS to provide enhanced availability to SAP environments. Oracle Solaris Cluster delivers instant support for SAP through specific integration modules called agents that monitor an application to detect whether it is operating correctly, or take action if a problem is detected.

The steps in this section are an example of Oracle Solaris Cluster setup for an SAP environment and would have to be repeated for each zone cluster to be created. The ctnet application allows connecting to multiple nodes using telnet or ssh and issuing commands that will be sent to all nodes, avoiding repetition. For more details see the Oracle Solaris Cluster Reference Manual.

Step 1. Configuring Hostnames Resolution

As a best practice, highly available environments should be able recover without dependency to external services, such as name resolution services, therefore any hostname used during the configuration should be resolvable on each node locally using the `/etc/hosts` file.

On each node, add to the global zone file `/etc/hosts`, all physical and logical hostnames as used for the zone clusters and SAP configurations.

Important considerations regarding hostname resolution

- All the hosts running SAP instances need to be in `/etc/hosts` with their fully qualified domain name (FQDN).
- Hosts with a name starting with an “e” can be accessed externally over the 10 GbE interfaces and should be resolvable by the infrastructure DNS or other name resolution services. It is recommended to include the FQDN for these hosts in the `/etc/hosts` file.
- Hosts with a name starting with an “i” are strictly internal (on the InfiniBand ports) and used within the SPARC SuperCluster system only. They do not need to be resolvable by the infrastructure DNS or any other name service outside of SPARC SuperCluster. It is however required to include the FQDN for these hosts in the `/etc/hosts` file.

The following example shows the file `/etc/hosts` from one of the node, as used in our example environment. Each node should have an identical configuration.

```

# cat >> /etc/hosts
# hostnames on the 10GbE network
10.129.184.150 esapdev1
10.129.184.151 esapdev2
10.129.184.152 esapdev3
10.129.184.153 esapdev4

10.129.184.154 escs1
10.129.184.155 escs2
10.129.184.156 escs3
10.129.184.157 escs4

10.129.184.158 eapps1
10.129.184.159 eapps2
10.129.184.160 eapps3
10.129.184.161 eapps4

10.129.184.162 epas1
10.129.184.163 epas2
10.129.184.164 epas3
10.129.184.165 epas4

10.129.184.166 esapdb-lh
10.129.184.167 escs-lh
10.129.184.168 erep-lh
10.129.184.169 ewas-lh
10.129.184.170 eapp1-lh
10.129.184.171 eapp2-lh
10.129.184.185 eapp3-lh
10.129.184.186 eapp4-lh
10.129.184.7 eapp5-lh
10.129.184.8 eapp6-lh
10.129.184.9 eapp7-lh
10.129.184.10 eapp8-lh
10.129.184.172 epas-lh

# hostnames on the IPoIB network
192.168.30.1 etc4sn1-stor etc4sn1-stor.example.domain.com
192.168.30.11 etc4-01-appl-stor etc4-01-appl-stor.example.domain.com
192.168.30.12 etc4-02-appl-stor etc4-02-appl-stor.example.domain.com
192.168.30.13 etc4-03-appl-stor etc4-03-appl-stor.example.domain.com
192.168.30.14 etc4-04-appl-stor etc4-04-appl-stor.example.domain.com
192.168.30.25 etc4-01-ib-vip
192.168.30.26 etc4-02-ib-vip
192.168.30.27 etc4-03-ib-vip
192.168.30.28 etc4-04-ib-vip
192.168.30.31 isapdev1
192.168.30.32 isapdev2
192.168.30.33 isapdev3
192.168.30.34 isapdev4 isapdev4.example.domain.com
192.168.30.35 isapdb-lh
192.168.30.41 iscs1
192.168.30.42 iscs2
192.168.30.43 iscs3
192.168.30.44 iscs4
192.168.30.45 iscs-lh iscs-lh.example.domain.com
192.168.30.46 irep-lh irep-lh.example.domain.com
192.168.30.51 iapps1
192.168.30.52 iapps2
192.168.30.53 iapps3
192.168.30.54 iapps4
192.168.30.55 iapp1-lh iapp1-lh.example.domain.com
192.168.30.56 iapp2-lh iapp2-lh.example.domain.com
192.168.30.57 iapp3-lh iapp3-lh.example.domain.com
192.168.30.58 iapp4-lh iapp4-lh.example.domain.com
192.168.30.66 iapp5-lh iapp5-lh.example.domain.com
192.168.30.67 iapp6-lh iapp6-lh.example.domain.com
192.168.30.68 iapp7-lh iapp7-lh.example.domain.com
192.168.30.69 iapp8-lh iapp8-lh.example.domain.com
192.168.30.61 ipas1
192.168.30.62 ipas2

```

192.168.30.63	ipas3	
192.168.30.64	ipas4	
192.168.30.65	ipas-1h	ipas-1h.example.domain.com

Step 2. Quorum device iSCSI LUN and NFS file systems

An iSCSI LUN must be configured on the clustered storage for use as the quorum device. A quorum device is a shared storage device or quorum server that is shared by two or more nodes and that contributes votes used to establish a quorum and prevent partitions. This step describes the creation and the configuration of the Quorum device.

2a) Adding a Quorum device

Execute the following commands on each Oracle Solaris 10 General Purpose domain:

```
# iscsiadm modify discovery -s enable
# iscsiadm list discovery
Discovery:
  Static: enabled
  Send Targets: disabled
  iSNS: disabled
# iscsiadm list initiator-node
Initiator node name: iqn.1986-03.com.sun:01:00144ffae18a.4e5b7811
Initiator node alias: ovmt-1
  Login Parameters (Default/Configured):
    Header Digest: NONE/-
    Data Digest: NONE/-
  Authentication Type: NONE
  RADIUS Server: NONE
  RADIUS access: unknown
  Tunable Parameters (Default/Configured):
    Session Login Response Time: 60/-
    Maximum Connection Retry Time: 180/-
    Login Retry Time Interval: 60/-
  Configured Sessions: 1

# hostname
etc4-01-app1
# iscsiadm modify initiator-node -A `hostname`

# hostname
etc4-02-app1
# iscsiadm modify initiator-node -N iqn.1986-03.com.sun:01:00144ffae18a.4e5b7812 -
A `hostname`

# hostname
etc4-03-app1
# iscsiadm modify initiator-node -N iqn.1986-03.com.sun:01:00144ffae18a.4e5b7813 -
A `hostname`

# hostname
etc4-04-app1
# iscsiadm modify initiator-node -N iqn.1986-03.com.sun:01:00144ffae18a.4e5b7814 -
A `hostname`
```

Check back on each node (example for 4 nodes):

Node 1:

```
# iscsiadm list initiator-node
Initiator node name: iqn.1986-03.com.sun:01:00144ffae18a.4e5b7811
Initiator node alias: etc4-01-appl
  Login Parameters (Default/Configured):
    Header Digest: NONE/-
    Data Digest: NONE/-
  Authentication Type: NONE
  RADIUS Server: NONE
  RADIUS access: unknown
  Tunable Parameters (Default/Configured):
    Session Login Response Time: 60/-
    Maximum Connection Retry Time: 180/-
    Login Retry Time Interval: 60/-
  Configured Sessions: 1
```

Node 2:

```
# iscsiadm list initiator-node
Initiator node name: iqn.1986-03.com.sun:01:00144ffae18a.4e5b7812
Initiator node alias: etc4-02-appl
  Login Parameters (Default/Configured):
    Header Digest: NONE/-
    Data Digest: NONE/-
  Authentication Type: NONE
  RADIUS Server: NONE
  RADIUS access: unknown
  Tunable Parameters (Default/Configured):
    Session Login Response Time: 60/-
    Maximum Connection Retry Time: 180/-
    Login Retry Time Interval: 60/-
  Configured Sessions: 1
```

Node 3:

```
# iscsiadm list initiator-node
Initiator node name: iqn.1986-03.com.sun:01:00144ffae18a.4e5b7813
Initiator node alias: etc4-03-appl
  Login Parameters (Default/Configured):
    Header Digest: NONE/-
    Data Digest: NONE/-
  Authentication Type: NONE
  RADIUS Server: NONE
  RADIUS access: unknown
  Tunable Parameters (Default/Configured):
    Session Login Response Time: 60/-
    Maximum Connection Retry Time: 180/-
    Login Retry Time Interval: 60/-
  Configured Sessions: 1
```

Node 4:

```
# iscsiadm list initiator-node
Initiator node name: iqn.1986-03.com.sun:01:00144ffae18a.4e5b7814
Initiator node alias: etc4-04-appl
  Login Parameters (Default/Configured):
    Header Digest: NONE/-
    Data Digest: NONE/-
  Authentication Type: NONE
  RADIUS Server: NONE
  RADIUS access: unknown
  Tunable Parameters (Default/Configured):
    Session Login Response Time: 60/-
    Maximum Connection Retry Time: 180/-
    Login Retry Time Interval: 60/-
  Configured Sessions: 1
```

2b) Configuring the Quorum Device

The iSCSI Quorum Device is configured using the Sun ZFS Storage Appliance graphical user interface.

In the Sun ZFS Storage Appliance (ZFSSA) GUI:

- Go to 7320 SAN Configuration
- create iSCSI Target "QuorumTarget"
- choose ipmp1 interface
- drag and drop it to the iSCSI Target Group to create a new group
- name it "QuorumGroup"
- click "Apply".

Write down the Target IQN

in our example: iqn.1986-03.com.sun:02:9ab50402-48ee-6c7f-a6fb-db2afe325e57

- Select the Initiators headlight
- create the iSCSI Initiator using the cluster nodes initiator id from above
- name them with nodes IB subnet internal hostname or 10GbE hostname
- drag and drop it to the iSCSI Initiator Group to create a new group
- name it QuorumGroup and select both iSCSI Initiators previously created
- click "Apply".

In the shares page

- Select Project
- create a new project "QuorumProject" in the app-pool pool.

In that project, in the LUNs tab

- Create a new LUN of 1G size
- name it QuorumLUN
- select the drop down menus to put it in the created QuorumGroup Target Group and the QuorumGroup Initiator Group
- select also LU Number 0 and Fix LU number
- click "Apply".

Execute the following on each node:

```
# iscsiadm add static-config iqn.1986-03.com.sun:02:9ab50402-48ee-6c7f-a6fb-
db2afe325e57,192.168.30.1

# iscsiadm list static-config
# iscsiadm list target -S
Target: iqn.1986-03.com.sun:02:9ab50402-48ee-6c7f-a6fb-db2afe325e57
  Alias: QuorumTarget
  TPGT: 2
  ISID: 4000002a0000
  Connections: 1
  LUN: 0
      Vendor: SUN
      Product: ZFS Storage 7320
```

```
OS Device Name: /dev/rdsk/c1t600144F0A67C70FB00004F2CA5A70001d0s2
```

From one of the nodes use the command format to create a VTOC for the LUN

```
# format
```

2c) Configure NFS file systems for SAP on the 7320c

Using the web management interface of the ZFS Storage appliance, go to the Shares panel and perform the following:

- Create a new project named "sap" set its "Mountpoint" property to "/export/etc4"
- In that project, create the following file systems and verify that they have the corresponding mount points:

NAME	MOUNTPOINT
oracle	/export/etc4/oracle
trans	/export/etc4/trans
PASshare	/export/etc4/PASshare
SCSshare	/export/etc4/SCSshare
sapmnt_Q01	/export/etc4/sapmnt_Q01
APPShare_Q01	/export/etc4/APPShare_Q01

- Create a new project named "oradb" set its "Mountpoint" property to "/export/etc4"
- In that project, create the following file systems and verify that they have the corresponding mount points:

NAME	MOUNTPOINT
saplog	/export/etc4/saplog
oraInst	/export/etc4/oraInst
sapdata	/export/etc4/sapdata

Note: The above operations for iSCSI Quorum device and NFS file systems could also be performed using the ZFS Storage appliance command line interface.

Step 3. Oracle Solaris Cluster installation

In this step we are going to install Oracle Solaris Cluster 3.3 5/11 Release (OSC3.3u1) for SPARC, as well as its latest associated patches and the Oracle External Proxy (OEP).

3a) Initial Steps

The next tasks will consist of downloading Oracle Solaris Cluster 3.3u1 and latest patches from the Oracle Technology Network (OTN) and My Oracle Support (MOS).

Since the steps will have to be performed on each node, it is recommended, and assumed that the files are copied to an NFS share, read-writable mounted on all Oracle Solaris 10 General Purpose domains. That NFS share could be created on the SPARC SuperCluster ZFS Storage Appliance. We will call the mounted location of that share **<OSC Installation NFS share dir>**.

From one Oracle Solaris 10 General Purpose domain, perform the following:

```
# mkdir <OSC Installation NFS share dir>/sap-ssc
# cd <OSC Installation NFS share dir>/sap-ssc
# mkdir OSC3.3u1 patches ZFSSA-SC-plugin oep
```

Download Oracle Solaris Cluster 3.3 5/11 Release (OSC3.3u1) for SPARC from OTN:

<http://www.oracle.com/technetwork/server-storage/solaris-cluster/downloads/index.html>

Save the downloaded file in <OSC Installation NFS share dir>/sap-ssc/OSC3.3u1, then unzip it:

```
# cd <OSC Installation NFS share dir>/sap-ssc/OSC3.3u1
# /bin/unzip solaris-cluster-3_3u1-ga-sparc.zip
```

Download the following patches for OSC3.3u1 from MOS (support.oracle.com) into the directory <OSC Installation NFS share dir>/sap-ssc/patches

145333-10
145335-09
145337-04
145341-04
145343-04
145345-03
146089-04
146091-06
146093-03
146762-04
146764-05

Then unzip the patches:

```
# cd <OSC Installation NFS share dir>/sap-ssc/patches
# /bin/unzip '*.zip'
# ls -l | grep -v zip > patch_order
# cat ./patch_order
145333-10
145335-09
145337-04
145341-04
145343-04
145345-03
146089-04
146091-06
146093-03
146762-04
146764-05
```

Download patch 12736304 (Generic Platform) from MOS (support.oracle.com) into the directory <OSC Installation NFS share dir>/sap-ssc/ZFSSA-SC-plugin and unzip it:

```
# cd <OSC Installation NFS share dir>/sap-ssc/ZFSSA-SC-plugin
# /bin/unzip p12736304_120_Generic.zip
# unzip SunZFSNFSSC.zip
```

Download from MOS (support.oracle.com) patch 13987101 for Oracle Solaris on SPARC in to the <OSC Installation NFS share dir>/sap-ssc/oep directory and unzip it:

```
# cd <OSC Installation NFS share dir>/sap-ssc/oep
# /bin/unzip p13987101_330_SOLARIS64.zip
Archive:  p13987101_330_SOLARIS64.zip
  inflating: readme.txt
 extracting: solaris-cluster-ha-external-proxy-3_3ul-sparc.zip
# /bin/unzip solaris-cluster-ha-external-proxy-3_3ul-sparc.zip
```

3b) Installing Oracle Solaris Cluster

From each node, run the JES installer:

```
# pwd
<OSC Installation NFS share dir>/sap-ssc/SC3.3ul/Solaris_sparc
# export DISPLAY=cheetah-c5:5
# ./installer
```

Select “Oracle Solaris Core”

- “HA for Oracle”
- “Support for Oracle RAC”
- “HA for SAP liveCache”
- “HA for SAPDB”
- “HA for SAP Web Application Server”
- “HA for SAP”

The summary should look like this:

```
Product: Oracle Solaris Cluster
Uninstall Location: /var/sadm/prod/SUNWentsysssc33u1
Space Required: 582.40 MB
-----
Java DB
  Java DB Server
  Java DB Client
Oracle Solaris Cluster 3.3ul
  Oracle Solaris Cluster Core
  Oracle Solaris Cluster Manager
Oracle Solaris Cluster Agents 3.3ul
  Oracle Solaris Cluster HA for Oracle
  Oracle Solaris Cluster Support for Oracle RAC
  Oracle Solaris Cluster HA for SAP liveCache
  Oracle Solaris Cluster HA for SAPDB
  Oracle Solaris Cluster HA for SAP Web Application Server
  Oracle Solaris Cluster HA for SAP
```

3c) Installing the latest patches

Once the software installation has completed, install the latest patches:

```
root@sup30: pwd
<OSC Installation NFS share dir>/sap-ssc/patches
```

```
# patchadd -M . ./patch_order
```

3d) Installing the Oracle External Proxy

```
root@sup30: pwd
<OSC Installation NFS share dir>/sap-ssc/oeop
```

The generic instructions on how this feature is installed and configured are provided in this file:

```
root@sup30: ls Docs/oracle-external-proxy.pdf
Docs/oracle-external-proxy.pdf
```

Install the Oracle External Proxy (OEP) package on each node:

```
# pwd
<OSC Installation NFS share dir>/sap-
ssc/oeop/Solaris_sparc/Product/sun_cluster_agents/Solaris_10/Packages
# ls
ORCLscoep
# pkgadd -d . ORCLscoep
# pkginfo ORCLscoep
application ORCLscoep Oracle Solaris Cluster HA for Oracle External Proxy
```

3e) Add /usr/cluster/bin to /etc/profile

Add /usr/cluster/bin to the PATH environment variable in /etc/profile

3f) Install the Sun ZFS Storage Appliance plugin for Oracle Solaris Cluster

```
# cd <OSC Installation NFS share dir>/sap-ssc/ZFSSA-SC-plugin
# pkgadd -d . SUNWsczfsnfs
```

Step 4. Configuring the Oracle Solaris 10 GP domains into a cluster

In this step we are going to configure the Oracle Solaris 10 General Purpose domains into a cluster.

First we must identify and write down the cluster "transport adapters" by running these commands on the last node:

```
# grep 8501 /etc/path to inst
"/pci@700/pci@2/pci@0/pci@3/pciex15b3,673c@0/ibport@2,8501,ipib" 7 "ibd"
# grep 8502 /etc/path to inst
"/pci@600/pci@2/pci@0/pci@3/pciex15b3,673c@0/ibport@1,8502,ipib" 1 "ibd"
```

ibd7 and ibd1 are respectively the first and second "transport adapters" to be used in the configuration.

From etc4-04-app1 (the last node)

```
# /usr/cluster/bin/scinstall
```

Use the typical options and provide the above adapters when asked.

Once all the nodes have been rebooted by this configuration task, log back in and check:

```
# clnode status
=== Cluster Nodes ===

--- Node Status ---

Node Name                               Status
-----
etc4-01-appl                            Online
etc4-02-appl                            Online
etc4-03-appl                            Online
etc4-04-appl                            Online

# clq status
=== Cluster Quorum ===

--- Quorum Votes Summary from (latest node reconfiguration) ---

          Needed   Present   Possible
          -----   -
          3         4         4

--- Quorum Votes by Node (current status) ---

Node Name           Present   Possible   Status
-----
etc4-01-appl        1         1         Online
etc4-02-appl        1         1         Online
etc4-03-appl        1         1         Online
etc4-04-appl        1         1         Online

# clintr status
=== Cluster Transport Paths ===

Endpoint1           Endpoint2           Status
-----
etc4-01-appl:ibd7   etc4-04-appl:ibd1   Path online
etc4-01-appl:ibd1   etc4-04-appl:ibd7   Path online
etc4-01-appl:ibd7   etc4-02-appl:ibd7   Path online
etc4-01-appl:ibd1   etc4-02-appl:ibd1   Path online
etc4-01-appl:ibd7   etc4-03-appl:ibd1   Path online
etc4-01-appl:ibd1   etc4-03-appl:ibd7   Path online
etc4-02-appl:ibd7   etc4-03-appl:ibd1   Path online
etc4-02-appl:ibd7   etc4-04-appl:ibd1   Path online
etc4-02-appl:ibd1   etc4-03-appl:ibd7   Path online
etc4-02-appl:ibd1   etc4-04-appl:ibd7   Path online
etc4-03-appl:ibd1   etc4-04-appl:ibd1   Path online
etc4-03-appl:ibd7   etc4-04-appl:ibd7   Path online

# scdidadm -L
1   etc4-01-appl:/dev/rdisk/clt5000C5004311C9AFd0 /dev/did/rdisk/d1
2   etc4-01-appl:/dev/rdisk/clt5000C500430FCC5Fd0 /dev/did/rdisk/d2
3   etc4-01-appl:/dev/rdisk/clt50015179596667C7d0 /dev/did/rdisk/d3
4   etc4-01-appl:/dev/rdisk/clt5001517959697454d0 /dev/did/rdisk/d4
5   etc4-03-appl:/dev/rdisk/clt600144F0A67C70FB00004F2CA5A70001d0
/dev/did/rdisk/d5
5   etc4-01-appl:/dev/rdisk/clt600144F0A67C70FB00004F2CA5A70001d0
/dev/did/rdisk/d5
5   etc4-02-appl:/dev/rdisk/clt600144F0A67C70FB00004F2CA5A70001d0
/dev/did/rdisk/d5
5   etc4-04-appl:/dev/rdisk/clt600144F0A67C70FB00004F2CA5A70001d0
/dev/did/rdisk/d5
6   etc4-02-appl:/dev/rdisk/clt50015179596332D6d0 /dev/did/rdisk/d6
7   etc4-02-appl:/dev/rdisk/clt50015179596974D9d0 /dev/did/rdisk/d7
8   etc4-02-appl:/dev/rdisk/clt5000C5004327733Fd0 /dev/did/rdisk/d8
9   etc4-02-appl:/dev/rdisk/clt5000C50043276973d0 /dev/did/rdisk/d9
10  etc4-03-appl:/dev/rdisk/clt5001517959697498d0 /dev/did/rdisk/d10
11  etc4-03-appl:/dev/rdisk/clt5000C50043551B2Fd0 /dev/did/rdisk/d11
```

```

12 etc4-03-appl:/dev/rdisk/clt5000C500432923B7d0 /dev/did/rdsk/d12
13 etc4-03-appl:/dev/rdisk/clt500151795966904Fd0 /dev/did/rdsk/d13
14 etc4-04-appl:/dev/rdisk/clt500151795966AFB4d0 /dev/did/rdsk/d14
15 etc4-04-appl:/dev/rdisk/clt5000C50043276D6Bd0 /dev/did/rdsk/d15
16 etc4-04-appl:/dev/rdisk/clt50015179596974CAAd0 /dev/did/rdsk/d16
17 etc4-04-appl:/dev/rdisk/clt5000C50043292B67d0 /dev/did/rdsk/d17

```

If the automatic quorum selection was not selected, add a quorum device now using the iSCSI LUN identified (as d5) above:

```

# clq add d5
# clq status

=== Cluster Quorum ===

--- Quorum Votes Summary from (latest node reconfiguration) ---

      Needed   Present   Possible
      -----   -
      4         7         7

--- Quorum Votes by Node (current status) ---

Node Name      Present   Possible   Status
-----
etc4-01-appl   1         1         Online
etc4-02-appl   1         1         Online
etc4-03-appl   1         1         Online
etc4-04-appl   1         1         Online

--- Quorum Votes by Device (current status) ---

Device Name     Present   Possible   Status
-----
d5              3         3         Online

```

Initial Zone Cluster Setup

Two types of clusters can be configured with the Oracle Solaris operating system: global clusters and zone clusters.

- **Global cluster.** The global cluster contains all global zones in a collection of Oracle Solaris hosts. Only the global zone in the global cluster has the privileges needed to perform administrative actions for a zone cluster.
- **Zone cluster.** A zone cluster is a virtual cluster composed of one or more non-global zones, which are all of zone brand type cluster. Each cluster node of a zone cluster resides on a different Oracle Solaris host. A zone cluster appears to applications as a cluster dedicated for those applications.

This section provides the steps to create the zone clusters and prepare the zone cluster environment for the SAP installation.

Step 5. Creation of the zone clusters for SAP

In this step we are going to prepare the storage and create the zone clusters.

5a) Prepare a dedicated ZFS file system for the zone clusters.

Execute the following on each node:

```
# zfs create -o mountpoint=/zones BIRpool/zones
# zfs list
NAME                USED  AVAIL  REFER  MOUNTPOINT
BIRpool              138G  136G   107K   /BIRpool
BIRpool/ROOT         24.5G  136G    31K   legacy
BIRpool/ROOT/s10s_u10wos_17b 24.5G  136G   24.5G   /
BIRpool/dump         64.0G  136G   64.0G   -
BIRpool/export        63K   136G    32K   /export
BIRpool/export/home   31K   136G    31K   /export/home
BIRpool/swap          49.5G  186G    16K   -
BIRpool/zones         31K   136G    31K   /zones
```

5b) Zone clusters creation

From node 1:

sapdev-zc zone cluster

```
# cat /var/tmp/sapdev-zc-sroot.conf
create
set zonepath=/zones/sapdev-zc
set autoboot=true
add sysid
set root_password=f/ouCDtWx.rIA
set name_service="NIS{domain_name=example.domain.com
name_server=ns.example.domain.com (10.129.184.238)}"
set nfs4_domain=dynamic
set security_policy=NONE
set system_locale=C
set terminal=xterms
set timezone=US/Pacific
end
add node
```

```
set physical-host=etc4-01-app1
set hostname=isapdev1
add net
set address=isapdev1
set physical=ibd3
end
add net
set address=esapdev1
set physical=ixgbe0
end
end
add node
set physical-host=etc4-02-app1
set hostname=isapdev2
add net
set address=isapdev2
set physical=ibd3
end
add net
set address=esapdev2
set physical=ixgbe0
end
end
add node
set physical-host=etc4-03-app1
set hostname=isapdev3
add net
set address=isapdev3
set physical=ibd3
end
add net
set address=esapdev3
set physical=ixgbe0
end
end
add node
set physical-host=etc4-04-app1
set hostname=isapdev4
add net
set address=isapdev4
set physical=ibd3
end
add net
set address=esapdev4
set physical=ixgbe0
end
end
set limitpriv="default,proc_prioctl,proc_clock_highres"
add net
set address=esapdb-lh
end
add net
set address=isapdb-lh
end
commit
# clzc configure -f /var/tmp/sapdev-zc-sroot.conf sapdev-zc
# time clzc install sapdev-zc
Waiting for zone install commands to complete on all the nodes of the zone cluster
"sapdev-zc"...

real    3m51.11s
user    1m2.43s
sys     1m5.37s

# time clzc boot sapdev-zc
Waiting for zone boot commands to complete on all the nodes of the zone cluster
"sapdev-zc"...

real    0m2.36s
user    0m0.19s
sys     0m0.04s
```

scs-zc zone cluster

```
# cat /var/tmp/scs-zc-sroot.conf
create
set zonepath=/zones/scs-zc
set autoboot=true
add sysid
set root_password=f/ouCDtWx.rIA
set name_service="NIS{domain_name=example.domain.com
name_server=ns.example.domain.com(10.129.184.238)}"
set nfs4_domain=dynamic
set security_policy=NONE
set system_locale=C
set terminal=xterms
set timezone=US/Pacific
end
add node
set physical-host=etc4-01-app1
set hostname=iscs1
add net
set address=iscs1
set physical=ibd3
end
add net
set address=escs1
set physical=ixgbe0
end
end
add node
set physical-host=etc4-02-app1
set hostname=iscs2
add net
set address=iscs2
set physical=ibd3
end
add net
set address=escs2
set physical=ixgbe0
end
end
add node
set physical-host=etc4-03-app1
set hostname=iscs3
add net
set address=iscs3
set physical=ibd3
end
add net
set address=escs3
set physical=ixgbe0
end
end
add node
set physical-host=etc4-04-app1
set hostname=iscs4
add net
set address=iscs4
set physical=ibd3
end
add net
set address=escs4
set physical=ixgbe0
end
end
set limitpriv="default,proc_prioctl,proc_clock_highres"
add net
set address=escs-1h
end
```

```

add net
set address=iscs-lh
end
add net
set address=erep-lh
end
add net
set address=irep-lh
end
commit

```

```

# time clzc configure -f /var/tmp/scs-zc-sroot.conf scs-zc

real    0m3.70s
user    0m0.10s
sys     0m0.07s
# time clzc install scs-zc
Waiting for zone install commands to complete on all the nodes of the zone cluster
"scs-zc"...

real    2m40.39s
user    1m4.25s
sys     1m1.82s
# time clzc boot scs-zc
Waiting for zone boot commands to complete on all the nodes of the zone cluster
"scs-zc"...

real    0m2.39s
user    0m0.19s
sys     0m0.04s

```

apps-zc zone cluster

```

# cat /var/tmp/apps-zc-sroot.conf
create
set zonepath=/zones/apps-zc
set autoboot=true
add sysid
set root_password=f/ouCDtWx.rIA
set name_service="NIS{domain name=example.domain.com
name_server=ns.example.domain.com(10.129.184.238)}"
set nfs4_domain=dynamic
set security_policy=NONE
set system_locale=C
set terminal=xterms
set timezone=US/Pacific
end
add node
set physical-host=etc4-01-app1
set hostname=iapps1
add net
set address=iapps1
set physical=ibd3
end
add net
set address=eapps1
set physical=ixgbe0
end
end
add node
set physical-host=etc4-02-app1
set hostname=iapps2
add net
set address=iapps2
set physical=ibd3
end
add net

```

```
set address=eapps2
set physical=ixgbe0
end
end
add node
set physical-host=etc4-03-app1
set hostname=iapps3
add net
set address=iapps3
set physical=ibd3
end
add net
set address=eapps3
set physical=ixgbe0
end
end
add node
set physical-host=etc4-04-app1
set hostname=iapps4
add net
set address=iapps4
set physical=ibd3
end
add net
set address=eapps4
set physical=ixgbe0
end
end
set limitpriv="default,proc_prioctl,proc_clock_highres"
add net
set address=eapp1-1h
end
add net
set address=iapp1-1h
end
add net
set address=eapp2-1h
end
add net
set address=iapp2-1h
end
add net
set address=eapp3-1h
end
add net
set address=iapp3-1h
end
add net
set address=eapp4-1h
end
add net
set address=iapp4-1h
end
add net
set address=eapp5-1h
end
add net
set address=iapp5-1h
end
add net
set address=eapp6-1h
end
add net
set address=iapp6-1h
end
add net
set address=eapp7-1h
end
add net
set address=iapp7-1h
end
end
```

```

add net
set address=eapp8-lh
end
add net
set address=iapp8-lh
end
commit

```

```

# time clzc configure -f /var/tmp/apps-zc-sroot.conf apps-zc

real    0m3.75s
user    0m0.11s
sys     0m0.07s
# time clzc install apps-zc
Waiting for zone install commands to complete on all the nodes of the zone cluster
"apps-zc"...

real    2m43.14s
user    1m4.84s
sys     1m2.02s
# time clzc boot apps-zc
Waiting for zone boot commands to complete on all the nodes of the zone cluster
"apps-zc"...

real    0m2.81s
user    0m0.20s
sys     0m0.04s

```

pas-zc zone cluster

```

# cat /var/tmp/pas-zc-sroot.conf
create
set zonepath=/zones/pas-zc
set autoboot=true
add sysid
set root_password=f/ouCDtWx.rIA
set name_service="NIS{domain name=example.domain.com
name_server=ns.example.domain.com(10.129.184.238)}"
set nfs4_domain=dynamic
set security_policy=NONE
set system_locale=C
set terminal=xterms
set timezone=US/Pacific
end
add node
set physical-host=etc4-01-app1
set hostname=ipas1
add net
set address=ipas1
set physical=ibd3
end
add net
set address=epas1
set physical=ixgbe0
end
end
add node
set physical-host=etc4-02-app1
set hostname=ipas2
add net
set address=ipas2
set physical=ibd3
end
add net
set address=epas2
set physical=ixgbe0
end

```

```

end
add node
set physical-host=etc4-03-app1
set hostname=ipas3
add net
set address=ipas3
set physical=ibd3
end
add net
set address=epas3
set physical=ixgbe0
end
end
add node
set physical-host=etc4-04-app1
set hostname=ipas4
add net
set address=ipas4
set physical=ibd3
end
add net
set address=epas4
set physical=ixgbe0
end
end
set limitpriv="default,proc_prioctl,proc_clock_highres"
add net
set address=epas-lh
end
add net
set address=ipas-lh
end
commit

```

```

# clzc configure -f /var/tmp/pas-zc-sroot.conf pas-zc
# time clzc install pas-zc
# time clzc boot pas-zc

# clzc status

=== Zone Clusters ===

--- Zone Cluster Status ---

Name          Node Name      Zone HostName  Status  Zone Status
----          -
sapdev-zc    etc4-01-app1   isapdev1       Online  Running
              etc4-02-app1   isapdev2       Online  Running
              etc4-03-app1   isapdev3       Online  Running
              etc4-04-app1   isapdev4       Online  Running

scs-zc       etc4-01-app1   iscs1          Online  Running
              etc4-02-app1   iscs2          Online  Running
              etc4-03-app1   iscs3          Online  Running
              etc4-04-app1   iscs4          Online  Running

apps-zc      etc4-01-app1   iapps1         Online  Running
              etc4-02-app1   iapps2         Online  Running
              etc4-03-app1   iapps3         Online  Running
              etc4-04-app1   iapps4         Online  Running

pas-zc       etc4-01-app1   ipas1          Online  Running
              etc4-02-app1   ipas2          Online  Running
              etc4-03-app1   ipas3          Online  Running
              etc4-04-app1   ipas4          Online  Running

```

Step 6. Preparing the zone cluster environment

On each node, edit the profile file for each zone cluster:

```
/zones/*/root/etc/profile
PATH=$PATH:/usr/cluster/bin

/zones/*-zc/root/etc/ssh/sshd_config
#PermitRootLogin no
PermitRootLogin yes

# for zc in `clzc list`; do zlogin $zc svcadm restart ssh; done
```

Add to the zone cluster hosts file all relevant entries in the global zone's hosts file (see step 1 for complete list and recommendations).

```
/zones/*/root/etc/hosts

# cat > /var/tmp/zc-hosts
# hostnames on the 10GbE network
10.129.184.150  esapdev1
...
# hostnames on the IPoIB network
192.168.30.1   etc4sn1-stor
...
192.168.30.65  ipas-lh
^D

# cat /var/tmp/zc-hosts >> /zones/sapdev-zc/root/etc/hosts
# cat /var/tmp/zc-hosts >> /zones/scs-zc/root/etc/hosts
# cat /var/tmp/zc-hosts >> /zones/apps-zc/root/etc/hosts
# cat /var/tmp/zc-hosts >> /zones/pas-zc/root/etc/hosts
```

Step 7. SPARC SuperCluster specific tuning

In /etc/system

```
* SSC tuning for SAP
set nfs:nfs3_bsize = 131072
set nfs:nfs4_bsize = 131072
set rpcmod:clnt_max_conns = 8
set zfs:zfs_arc_max = 0x1000000000
set rlim_fd_cur=8192
set pg_contig_disable=1
```

Note: set rlim_fd_cur=8192 (parameter can be deleted after SAP installation)

```
# cat > /etc/rc2.d/S99ndd
ndd -set /dev/tcp tcp_xmit_hiwat 1048576
ndd -set /dev/tcp tcp_recv_hiwat 1048576
ndd -set /dev/tcp tcp_cwnd_max 2097152
ndd -set /dev/tcp tcp_max_buf 2097152
# chmod a+rx /etc/rc2.d/S99ndd
```

Step 8. Creating initial resource groups and logical host resources

In this step we create the initial resource groups and the associated logical host resources for the zone clusters.

8a) scs-zc zone cluster

```
# zlogin scs-zc
[Connected to zone 'scs-zc' pts/3]
Last login: Sat Feb  4 17:02:48 on console
Oracle Corporation      SunOS 5.10      Generic Patch   January 2005
# ksh -o emacs
# clrg create scs-rg
# clrslh create -g scs-rg escs-lh
# clrslh create -g scs-rg iscs-lh
# clrg online -eM scs-rg
# clrg create rep-rg
# clrslh create -g rep-rg erep-lh
# clrslh create -g rep-rg irep-lh
# clrg online -eM rep-rg
```

Note: Once central services are installed and running, additional affinities will have to be configured.

8b) pas-zc zone cluster

```
# zlogin pas-zc
[Connected to zone 'pas-zc' pts/3]
Last login: Sat Feb  4 17:27:15 on console
Oracle Corporation      SunOS 5.10      Generic Patch   January 2005
# ksh -o emacs
# clrg create pas-rg
# clrslh create -g pas-rg epas-lh
# clrslh create -g pas-rg ipas-lh
# clrg online -eM pas-rg
# clrsl status

=== Cluster Resources ===

Resource Name      Node Name      State      Status Message
-----
ipas-lh            ipas1          Online     Online - LogicalHostname online.
                   ipas2          Offline    Offline
                   ipas3          Offline    Offline
                   ipas4          Offline    Offline
epas-lh            ipas1          Online     Online - LogicalHostname online.
                   ipas2          Offline    Offline
                   ipas3          Offline    Offline
                   ipas4          Offline    Offline
```

8c) apps-zc zone cluster

```
# zlogin apps-zc
[Connected to zone 'apps-zc' pts/3]
Last login: Sat Feb  4 17:14:16 on console
Oracle Corporation      SunOS 5.10      Generic Patch   January 2005
# ksh -o emacs
# clrg create -p failback=true -n 1,2,3,4 D51-rg
# clrg create -p failback=true -n 2,3,4,1 D52-rg
# clrg create -p failback=true -n 3,4,1,2 D53-rg
# clrg create -p failback=true -n 4,1,2,3 D54-rg
# clrg create -p failback=true -n 1,2,3,4 D55-rg
# clrg create -p failback=true -n 2,3,4,1 D56-rg
# clrg create -p failback=true -n 3,4,1,2 D57-rg
# clrg create -p failback=true -n 4,1,2,3 D58-rg
# clrslh create -g D51-rg eapp1-lh
# clrslh create -g D52-rg eapp2-lh
# clrslh create -g D53-rg eapp3-lh
# clrslh create -g D54-rg eapp4-lh
```

```
# clrslh create -g D55-rg eapp5-lh
# clrslh create -g D56-rg eapp6-lh
# clrslh create -g D57-rg eapp7-lh
# clrslh create -g D58-rg eapp8-lh
# clrslh create -g D51-rg iapp1-lh
# clrslh create -g D52-rg iapp2-lh
# clrslh create -g D53-rg iapp3-lh
# clrslh create -g D54-rg iapp4-lh
# clrslh create -g D55-rg iapp5-lh
# clrslh create -g D56-rg iapp6-lh
# clrslh create -g D57-rg iapp7-lh
# clrslh create -g D58-rg iapp8-lh
# clrg online -eM +
```

8d) sapdev-zc zone cluster

```
# zlogin sapdev-zc
# ksh -o emacs
# clrg create sapdb-rg
# clrslh create -g sapdb-rg esapdb-lh
# clrslh create -g sapdb-rg isapdb-lh
# clrg online -eM sapdb-rg
```

Step 9. Preparing the NFS file systems for Zone Clusters

The SAP installer and runtime procedures are all hard-coded to use `/usr/sap`.

Zone clusters are created as sparse-root zones, to minimize the local storage requirement for the zone path and to speed up the zone cluster installation by reducing the number of files to copy. For these reasons, `/usr` is a read-only file system in the zone cluster, i.e. the user cannot create any new sub directories under `/usr`. Additionally, `/opt` is on a private writable file system in the zone cluster.

Therefore a symbolic link from `/usr/sap` to `/opt/sap` will fulfill both requirements: SAP sees `/usr/sap` as expected, and from inside the zone cluster, the user can create any new sub directories under `/usr/sap`.

On all nodes, create this symbolic link in the global zone:

```
# ln -s /opt/sap /usr/sap
```

Log in to each zone cluster to create a mount point and add entries in `/etc/vfstab`

9a) sapdev-zc zone cluster

```
# zlogin sapdev-zc
# mkdir -p /oracle /sapmnt/Q01 /opt/sap/trans
# mkdir /oraInst /sapdata /saplog
```

Add to `/etc/vfstab`:

```
# SAP file systems
etc4sn1-stor:/export/etc4/oracle - /oracle nfs - yes
rw,bg,hard,nointr,rsiz=131072,wsiz=131072,proto=tcp,vers=3,noac,suid
etc4sn1-stor:/export/etc4/sapmnt_Q01 - /sapmnt/Q01 nfs - yes
rw,bg,hard,nointr,rsiz=131072,wsiz=131072,proto=tcp,vers=3
```

```

etc4sn1-stor:/export/etc4/trans      - /opt/sap/trans nfs - yes
rw,bg,hard,nointr,rsize=131072,ws
size=131072,proto=tcp,vers=3
etc4sn1-stor:/export/etc4/orainst   - /orainst      nfs - yes
rw,bg,hard,nointr,rsize=131072,ws
size=131072,proto=tcp,vers=3,noac,
suid
etc4sn1-stor:/export/etc4/sapdata   - /sapdata      nfs - yes
rw,bg,hard,nointr,rsize=131072,ws
size=131072,proto=tcp,vers=3,noac,
suid,forcedirect
io
etc4sn1-stor:/export/etc4/saplog    - /saplog       nfs - yes
rw,bg,hard,nointr,rsize=131072,ws
size=131072,proto=tcp,vers=3,noac,
suid,forcedirect
io

```

```

# mountall
# df -h -F nfs
Filesystem                size  used  avail capacity  Mounted on
etc4sn1-stor:/export/etc4/orainst
                          16T   31K   16T     1%   /orainst
etc4sn1-stor:/export/etc4/oracle
                          16T   31K   16T     1%   /oracle
etc4sn1-stor:/export/etc4/sapmnt_Q01
                          16T   31K   16T     1%   /sapmnt/Q01
etc4sn1-stor:/export/etc4/sapdata
                          16T   31K   16T     1%   /sapdata
etc4sn1-stor:/export/etc4/trans
                          16T   31K   16T     1%   /opt/sap/trans
etc4sn1-stor:/export/etc4/saplog
                          16T   31K   16T     1%   /saplog

```

9b) scs-zc zone cluster

```

# zlogin scs-zc
[Connected to zone 'scs-zc' pts/4]
Last login: Sat Feb  4 19:33:25 on pts/3
Oracle Corporation      SunOS 5.10      Generic Patch    January 2005
# ksh -o emacs
# mkdir -p /oracle /sapmnt/Q01 /opt/sap

```

Add to /etc/vfstab:

```

# SAP file systems
etc4sn1-stor:/export/etc4/oracle   - /oracle       nfs - no
rw,bg,hard,nointr,rsize=131072,ws
size=131072,proto=tcp,vers=3,noac,
suid
etc4sn1-stor:/export/etc4/sapmnt_Q01
- /sapmnt/Q01   nfs - no
rw,bg,hard,nointr,rsize=131072,ws
size=131072,proto=tcp,vers=3
etc4sn1-stor:/export/etc4/SCSshare  - /opt/sap      nfs - no
rw,bg,hard,nointr,rsize=131072,ws
size=131072,proto=tcp,vers=3
etc4sn1-stor:/export/etc4/trans     - /opt/sap/trans
nfs - no
rw,bg,hard,nointr,rsize=131072,ws
size=131072,proto=tcp,vers=3

```

```

# mount /oracle /sapmnt/Q01 /opt/sap

# mkdir /opt/sap/trans
# mount /opt/sap/trans

# df -h -F nfs
Filesystem                size  used  avail capacity  Mounted on
etc4sn1-stor:/export/etc4/oracle
                          16T   31K   16T     1%   /oracle
etc4sn1-stor:/export/etc4/sapmnt_Q01
                          16T   31K   16T     1%   /sapmnt/Q01
etc4sn1-stor:/export/etc4/SCSshare
                          16T   31K   16T     1%   /opt/sap
etc4sn1-stor:/export/etc4/trans

```

16T	31K	16T	1%	/opt/sap/trans
-----	-----	-----	----	----------------

9c) pas-zc zone cluster

```
# zlogin pas-zc
[Connected to zone 'pas-zc' pts/4]
Last login: Sat Feb  4 21:28:16 on pts/3
Oracle Corporation      SunOS 5.10      Generic Patch   January 2005
# ksh -o emacs
# mkdir -p /oracle /sapmnt/Q01 /opt/sap
```

Add to /etc/vfstab:

```
# SAP file systems
etc4sn1-stor:/export/etc4/oracle - /oracle      nfs - no
rw,bg,hard,nointr,rsiz=131072,wsiz=131072,proto=tcp,vers=3,noac,suid
etc4sn1-stor:/export/etc4/sapmnt_Q01 - /sapmnt/Q01  nfs - no
rw,bg,hard,nointr,rsiz=131072,wsiz=131072,proto=tcp,vers=3
etc4sn1-stor:/export/etc4/PASshare - /opt/sap     nfs - no
rw,bg,hard,nointr,rsiz=131072,wsiz=131072,proto=tcp,vers=3
etc4sn1-stor:/export/etc4/trans - /opt/sap/trans nfs - no
rw,bg,hard,nointr,rsiz=131072,wsiz=131072,proto=tcp,vers=3
```

```
# mount /oracle /sapmnt/Q01 /opt/sap

# mkdir /opt/sap/trans
# mount /opt/sap/trans

# df -h -F nfs
Filesystem      size  used  avail capacity  Mounted on
etc4sn1-stor:/export/etc4/oracle
                16T   31K   16T     1%    /oracle
etc4sn1-stor:/export/etc4/sapmnt_Q01
                16T   31K   16T     1%    /sapmnt/Q01
etc4sn1-stor:/export/etc4/PASshare
                16T   31K   16T     1%    /opt/sap
etc4sn1-stor:/export/etc4/trans
                16T   31K   16T     1%    /opt/sap/trans
```

9d) apps-zc zone cluster

```
# zlogin apps-zc
[Connected to zone 'apps-zc' pts/4]
Last login: Sat Feb  4 19:40:37 on pts/3
Oracle Corporation      SunOS 5.10      Generic Patch   January 2005
# ksh -o emacs
# mkdir -p /oracle /sapmnt/Q01 /opt/sap
```

Add to /etc/vfstab:

```
# SAP file systems
etc4sn1-stor:/export/etc4/oracle - /oracle      nfs - no
rw,bg,hard,nointr,rsiz=131072,wsiz=131072,proto=tcp,vers=3,noac,suid
etc4sn1-stor:/export/etc4/sapmnt_Q01 - /sapmnt/Q01  nfs - no
rw,bg,hard,nointr,rsiz=131072,wsiz=131072,proto=tcp,vers=3
etc4sn1-stor:/export/etc4/APPSshare_Q01 - /opt/sap     nfs - no
rw,bg,hard,nointr,rsiz=131072,wsiz=131072,proto=tcp,vers=3
etc4sn1-stor:/export/etc4/trans - /opt/sap/trans nfs - no
rw,bg,hard,nointr,rsiz=131072,wsiz=131072,proto=tcp,vers=3
```

```
# mount /oracle /sapmnt/Q01 /opt/sap
# mkdir /opt/sap/trans
# mount /opt/sap/trans

# df -h -F nfs
Filesystem                size      used  avail capacity  Mounted on
etc4sn1-stor:/export/etc4/oracle
                          16T       31K   16T      1%    /oracle
etc4sn1-stor:/export/etc4/sapmnt_Q01
                          16T       31K   16T      1%    /sapmnt/Q01
etc4sn1-stor:/export/etc4/APFSshare_Q01
                          16T       31K   16T      1%    /opt/sap
etc4sn1-stor:/export/etc4/trans
                          16T       31K   16T      1%    /opt/sap/trans
```

Step 10. Configuring the plug-in for Oracle Solaris Cluster fencing and creating storage resources

Configure the Sun ZFS Server Appliance plug-in for Oracle Solaris Cluster fencing and create the storage resources

```
oracle> ssh -l root etc4-snl
Password:
Last login: Mon Mar  5 21:58:50 2012 from 10.129.205.70
etc4-snl:> shares
etc4-snl:shares> select sap
etc4-snl:shares sap> ls
Properties:
      aclinherit = restricted
      aclmode = discard
      atime = true
      checksum = fletcher4
      compression = off
      dedup = false
      compressratio = 100
      copies = 1
      creation = Sun Feb 05 2012 05:34:58 GMT+0000 (UTC)
      logbias = latency
      mountpoint = /export/etc4
      quota = 0
      readonly = false
      recordsize = 128K
      reservation = 0
      rstchown = true
      secondarycache = all
      nbmand = false
      sharesmb = off
      sharenfs = sec=sys,rw,root=@192.168.30.0/24
      snapdir = hidden
      vscan = false
      sharedav = off
      shareftp = off
      sharesftp = off
      sharetftp =
      pool = ssc
      canonical_name = ssc/local/sap
      default_group = other
      default_permissions = 700
      default_sparse = false
      default_user = nobody
      default_vobblocksize = 8K
      default_volsize = 0
      exported = true
      nodestroy = false
      space_data = 373G
```

```

        space_unused_res = 0
    space_unused_res_shares = 0
        space_snapshots = 0
        space_available = 15.6T
        space_total = 373G
        origin =

Shares:

Filesystems:

NAME          SIZE      MOUNTPOINT
oracle        31K       /export/etc4/oracle
trans         31K       /export/etc4/trans
PASshare      31K       /export/etc4/PASshare
SCSshare      31K       /export/etc4/SCSshare
sapmnt_Q01    31K       /export/etc4/sapmnt_Q01
APPSshare_Q01 31K       /export/etc4/APPSshare_Q01

Children:

        groups => View per-group usage and manage group
                quotas
        replication => Manage remote replication
        snapshots => Manage snapshots
        users => View per-user usage and manage user quotas

etc4-snl:shares sap> get sharenfs
        sharenfs = sec=sys,rw,root=@192.168.30.0/24
etc4-snl:shares sap> get readonly
        readonly = false

```

Identify and write down the IPoIB zone cluster hostnames:

```

192.168.30.41 iscs1
192.168.30.42 iscs2
192.168.30.43 iscs3
192.168.30.44 iscs4
192.168.30.51 iapps1
192.168.30.52 iapps2
192.168.30.53 iapps3
192.168.30.54 iapps4
192.168.30.61 ipas1
192.168.30.62 ipas2
192.168.30.63 ipas3
192.168.30.64 ipas4

```

```

etc4-snl:shares sap> set
sharenfs="sec=sys,root=@192.168.30.0/24:@192.168.30.41/32:@192.168.30.42/32:@192.168.30.43/32:@192.168.30.44/32:@192.168.30.51/32:@192.168.30.52/32:@192.168.30.53/32:@192.168.30.54/32:@192.168.30.61/32:@192.168.30.62/32:@192.168.30.63/32:@192.168.30.64/32,rw=@192.168.30.0/24:@192.168.30.41/32:@192.168.30.42/32:@192.168.30.43/32:@192.168.30.44/32:@192.168.30.51/32:@192.168.30.52/32:@192.168.30.53/32:@192.168.30.54/32:@192.168.30.61/32:@192.168.30.62/32:@192.168.30.63/32:@192.168.30.64/32"
        sharenfs =
sec=sys,root=@192.168.30.0/24:@192.168.30.41/32:@192.168.30.42/32:@192.168.30.43/32:@192.168.30.44/32:@192.168.30.51/32:@192.168.30.52/32:@192.168.30.53/32:@192.168.30.54/32:@192.168.30.61/32:@192.168.30.62/32:@192.168.30.63/32:@192.168.30.64/32,rw=@192.168.30.0/24:@192.168.30.41/32:@192.168.30.42/32:@192.168.30.43/32:@192.168.30.44/32:@192.168.30.51/32:@192.168.30.52/32:@192.168.30.53/32:@192.168.30.54/32:@192.168.30.61/32:@192.168.30.62/32:@192.168.30.63/32:@192.168.30.64/32
(uncommitted)
etc4-snl:shares sap> commit
etc4-snl:shares sap> get sharenfs

```

```

sharenfs =
sec=sys,root=@192.168.30.0/24:@192.168.30.41/32:@192.168.30.42/32:@192.168.30.43/3
2:@192.168.30.44/32:@192.168.30.51/32:@192.168.30.52/32:@192.168.30.53/32:@192.168
.30.54/32:@192.168.30.61/32:@192.168.30.62/32:@192.168.30.63/32:@192.168.30.64/32,
rw=@192.168.30.0/24:@192.168.30.41/32:@192.168.30.42/32:@192.168.30.43/32:@192.168
.30.44/32:@192.168.30.51/32:@192.168.30.52/32:@192.168.30.53/32:@192.168.30.54/32:
etc4-snl:shares sap> get readonly
        readonly = false

```

```

etc4-snl:shares sap> cd ../../
etc4-snl:> maintenance workflows
etc4-snl:maintenance workflows> ls
Properties:
        showhidden = false

Workflows:
WORKFLOW      NAME                                OWNER      SETID ORIGIN
workflow-000  Configure for Oracle Solaris Cluster NFS root      false Oracle
Corporation
workflow-001  Unconfigure Oracle Solaris Cluster NFS root      false Oracle
Corporation
workflow-002  Configure for Oracle Enterprise Manager Monitoring root      false
Sun Microsystems, Inc.
workflow-003  Unconfigure Oracle Enterprise Manager Monitoring root      false Sun
Microsystems, Inc.

```

```

etc4-snl:maintenance workflows> select workflow-000
etc4-snl:maintenance workflow-000> execute
etc4-snl:maintenance workflow-000 execute (uncommitted)> set password=welcome1
        password = *****
etc4-snl:maintenance workflow-000 execute (uncommitted)> set changePassword=false
        changePassword = false
etc4-snl:maintenance workflow-000 execute (uncommitted)> commit
OSC configuration successfully completed.
etc4-snl:maintenance workflow-000> ls
Properties:
        name = Configure for Oracle Solaris Cluster NFS
description = Sets up environment for Oracle Solaris Cluster
NFS
        owner = root
        origin = Oracle Corporation
        setid = false
        alert = false
        scheduled = false

```

```

etc4-snl:maintenance workflow-000> cd ../../
etc4-snl:maintenance> cd ..
etc4-snl:> configuration users
etc4-snl:configuration users> show
Users:
NAME                                USERNAME      UID      TYPE
Oracle Solaris Cluster Agent osc_agent 2000000000 Loc
Super-User                          root         0        Loc

```

10a) scs-zc zone cluster

```

# zlogin scs-zc
[Connected to zone 'scs-zc' pts/22]
Last login: Wed Mar 21 07:50:43 from ipas1
Oracle Corporation      SunOS 5.10      Generic Patch      January 2005

```

```
# ksh -o emacs
# getent hosts `clnode list`
192.168.30.41 iscs1
192.168.30.42 iscs2
192.168.30.43 iscs3
192.168.30.44 iscs4
# clnas add -t sun_uss -p userid=osc_agent etc4sn1-stor
Enter password:
(welcome1)
```

```
# clnas set -p "nodeIPs{iscs1}"=192.168.30.41 \
-p "nodeIPs{iscs2}"=192.168.30.42 \
-p "nodeIPs{iscs3}"=192.168.30.43 \
-p "nodeIPs{iscs4}"=192.168.30.44 etc4sn1-stor
# clnas find-dir etc4sn1-stor

=== NAS Devices ===

Nas Device:                               etc4sn1-stor
Type:                                       sun_uss
Unconfigured Project:                       ssc/local/QuorumProject
Unconfigured Project:                       ssc/local/oradb
Unconfigured Project:                       ssc/local/sap
```

```
# clnas add-dir -d ssc/local/sap etc4sn1-stor
# clnas show -v -d all

=== NAS Devices ===

Nas Device:                               etc4sn1-stor
Type:                                       sun_uss
userid:                                    osc_agent
nodeIPs{iscs4}:                             192.168.30.44
nodeIPs{iscs3}:                             192.168.30.43
nodeIPs{iscs2}:                             192.168.30.42
nodeIPs{iscs1}:                             192.168.30.41
Project:                                     ssc/local/sap
File System:                                /export/etc4/oracle
File System:                                /export/etc4/SCSshare
File System:                                /export/etc4/PASshare
File System:                                /export/etc4/sapmnt_Q01
File System:                                /export/etc4/trans
File System:                                /export/etc4/APPSshare_Q01
```

```
# clrg create -S scalmnt-rg
# df -h -F nfs
Filesystem                size  used  avail capacity  Mounted on
etc4sn1-stor:/export/etc4/oracle
                        16T   31K   16T     1%   /oracle
etc4sn1-stor:/export/etc4/sapmnt_Q01
                        16T   31K   16T     1%   /sapmnt/Q01
etc4sn1-stor:/export/etc4/SCSshare
                        16T   31K   16T     1%   /opt/sap
etc4sn1-stor:/export/etc4/trans
                        16T   31K   16T     1%   /opt/sap/trans
```

```
# tail -5 /etc/vfstab
# SAP file systems
etc4sn1-stor:/export/etc4/oracle - /oracle      nfs - no
rw,bg,hard,nointr,rsize=131072,wsiz=131072,proto=tcp,vers=3,noac,suid
etc4sn1-stor:/export/etc4/sapmnt_Q01 - /sapmnt/Q01  nfs - no
rw,bg,hard,nointr,rsize=131072,wsiz=131072,proto=tcp,vers=3
etc4sn1-stor:/export/etc4/SCSshare - /opt/sap     nfs - no
rw,bg,hard,nointr,rsize=131072,wsiz=131072,proto=tcp,vers=3
```



```
etc4sn1-stor:/export/etc4/trans - /opt/sap/trans nfs - no
rw,bg,hard,nointr,rsiz=131072,wsiz=131072,proto=tcp,vers=3
```

Mount at boot set to "no"

```
# clrt register ScalMountPoint
# clrs create -d -g scalmnt-rg -t ScalMountPoint -x MountPointDir=/oracle \
-x FileSystemType=nas \
-x TargetFileSystem=etc4sn1-stor:/export/etc4/oracle ora-fs-rs

# clrs create -d -g scalmnt-rg -t ScalMountPoint -x MountPointDir=/sapmnt/Q01 \
-x FileSystemType=nas \
-x TargetFileSystem=etc4sn1-stor:/export/etc4/sapmnt_Q01 sapmnt-fs-rs

# clrs create -d -g scalmnt-rg -t ScalMountPoint -x MountPointDir=/opt/sap \
-x FileSystemType=nas \
-x TargetFileSystem=etc4sn1-stor:/export/etc4/SCSshare usrsap-fs-rs
# clrs create -d -g scalmnt-rg -t ScalMountPoint \
-x MountPointDir=/opt/sap/trans -x FileSystemType=nas \
-x TargetFileSystem=etc4sn1-stor:/export/etc4/trans \
-p Resource_dependencies_offline_restart=usrsap-fs-rs trans-fs-rs
# clrg online -eM scalmnt-rg
# clrs status -g scalmnt-rg
```

=== Cluster Resources ===

Resource Name	Node Name	State	Status Message
trans-fs-rs	iscs1	Online	Online
	iscs2	Online	Online
	iscs3	Online	Online
	iscs4	Online	Online
usrsap-fs-rs	iscs1	Online	Online
	iscs2	Online	Online
	iscs3	Online	Online
	iscs4	Online	Online
sapmnt-fs-rs	iscs1	Online	Online
	iscs2	Online	Online
	iscs3	Online	Online
	iscs4	Online	Online
ora-fs-rs	iscs1	Online	Online
	iscs2	Online	Online
	iscs3	Online	Online
	iscs4	Online	Online

10b) pas-zc zone cluster

```
# zlogin pas-zc
[Connected to zone 'pas-zc' pts/22]
Last login: Sun Mar 25 15:39:58 on pts/9
Oracle Corporation      SunOS 5.10      Generic Patch   January 2005
You have new mail.
# ksh -o emacs
# getent hosts `clnode list`
192.168.30.61 ipas1 loghost
192.168.30.62 ipas2
192.168.30.63 ipas3
192.168.30.64 ipas4
# clnas add -t sun_uss -p userid=osc_agent etc4sn1-stor
Enter password:
(welcome1)
```

```
# clnas set \
-p "nodeIPs{ipas1}"=192.168.30.61 \
-p "nodeIPs{ipas2}"=192.168.30.62 \
-p "nodeIPs{ipas3}"=192.168.30.63 \
-p "nodeIPs{ipas4}"=192.168.30.64 etc4sn1-stor
# clnas find-dir etc4sn1-stor

=== NAS Devices ===

Nas Device:                               etc4sn1-stor
Type:                                         sun_uss
Unconfigured Project:                       ssc/local/QuorumProject
Unconfigured Project:                       ssc/local/oradb
Unconfigured Project:                       ssc/local/sap
```

```
# clnas add-dir -d ssc/local/sap etc4sn1-stor
# clnas show -v -d all

# clrg create -S scalmnt-rg
# df -h -F nfs
Filesystem                size  used  avail capacity  Mounted on
etc4sn1-stor:/export/etc4/oracle
                          16T   31K   16T     1%    /oracle
etc4sn1-stor:/export/etc4/sapmnt_Q01
                          16T   31K   16T     1%    /sapmnt/Q01
etc4sn1-stor:/export/etc4/PASshare
                          16T   31K   16T     1%    /opt/sap
etc4sn1-stor:/export/etc4/trans
                          16T   31K   16T     1%    /opt/sap/trans
```

```
# tail -5 /etc/vfstab
# SAP file systems
etc4sn1-stor:/export/etc4/oracle - /oracle      nfs - no
rw,bg,hard,nointr,rsize=131072,wsiz=131072,proto=tcp,vers=3,noac,suid
etc4sn1-stor:/export/etc4/sapmnt_Q01 - /sapmnt/Q01  nfs - no
rw,bg,hard,nointr,rsize=131072,wsiz=131072,proto=tcp,vers=3
etc4sn1-stor:/export/etc4/PASshare - /opt/sap    nfs - no
rw,bg,hard,nointr,rsize=131072,wsiz=131072,proto=tcp,vers=3
etc4sn1-stor:/export/etc4/trans - /opt/sap/trans nfs - no
rw,bg,hard,nointr,rsize=131072,wsiz=131072,proto=tcp,vers=3
```

=> Mount at boot set to "no"

```
# clrt register ScalMountPoint

# clrs create -d -g scalmnt-rg -t ScalMountPoint -x MountPointDir=/oracle \
-x FileSystemType=nas \
-x TargetFileSystem=etc4sn1-stor:/export/etc4/oracle ora-fs-rs
# clrs create -d -g scalmnt-rg -t ScalMountPoint -x MountPointDir=/sapmnt/Q01 \
-x FileSystemType=nas \
-x TargetFileSystem=etc4sn1-stor:/export/etc4/sapmnt_Q01 sapmnt-fs-rs
# clrs create -d -g scalmnt-rg -t ScalMountPoint -x MountPointDir=/opt/sap \
-x FileSystemType=nas \
-x TargetFileSystem=etc4sn1-stor:/export/etc4/PASshare usrsap-fs-rs
# clrs create -d -g scalmnt-rg -t ScalMountPoint \
-x MountPointDir=/opt/sap/trans -x FileSystemType=nas \
-x TargetFileSystem=etc4sn1-stor:/export/etc4/trans \
-p Resource_dependencies_offline_restart=usrsap-fs-rs trans-fs-rs
# clrg online -eM scalmnt-rg
# clrs status -g scalmnt-rg

=== Cluster Resources ===

Resource Name      Node Name      State      Status Message
-----
-----
-----
-----
```

trans-fs-rs	ipas1	Online	Online
	ipas2	Online	Online
	ipas3	Online	Online
	ipas4	Online	Online
usrsap-fs-rs	ipas1	Online	Online
	ipas2	Online	Online
	ipas3	Online	Online
	ipas4	Online	Online
sapmnt-fs-rs	ipas1	Online	Online
	ipas2	Online	Online
	ipas3	Online	Online
	ipas4	Online	Online
ora-fs-rs	ipas1	Online	Online
	ipas2	Online	Online
	ipas3	Online	Online
	ipas4	Online	Online

```
# clrg status
=== Cluster Resource Groups ===
```

Group Name	Node Name	Suspended	Status
pas-rg	ipas1	No	Offline
	ipas2	No	Offline
	ipas3	No	Online
	ipas4	No	Offline
scalmnt-rg	ipas1	No	Online
	ipas2	No	Online
	ipas3	No	Online
	ipas4	No	Online

10c) apps-zc zone cluster

```
# zlogin apps-zc
[Connected to zone 'apps-zc' pts/22]
Last login: Sun Mar 25 15:52:12 on pts/9
Oracle Corporation      SunOS 5.10      Generic Patch   January 2005
# ksh -o emacs
# getent hosts `clnode list`
192.168.30.51  iapps1
192.168.30.52  iapps2
192.168.30.53  iapps3
192.168.30.54  iapps4
# clnas add -t sun_uss -p userid=osc_agent etc4sn1-stor
Enter password:
# clnas set \
-p "nodeIPs{iapps1}"=192.168.30.51 \
-p "nodeIPs{iapps2}"=192.168.30.52 \
-p "nodeIPs{iapps3}"=192.168.30.53 \
-p "nodeIPs{iapps4}"=192.168.30.54 etc4sn1-stor
# clnas find-dir etc4sn1-stor

=== NAS Devices ===

Nas Device:                               etc4sn1-stor
Type:                                         sun_uss
Unconfigured Project:                       ssc/local/QuorumProject
Unconfigured Project:                       ssc/local/oradb
Unconfigured Project:                       ssc/local/sap

# clnas add-dir -d ssc/local/sap etc4sn1-stor
# clnas show -v -d all

# clrg create -S scalmnt-rg
```

```
# df -h -F nfs
Filesystem                size      used  avail capacity  Mounted on
etc4sn1-stor:/export/etc4/oracle
                          16T       31K   16T     1%    /oracle
etc4sn1-stor:/export/etc4/sapmnt_Q01
                          16T       31K   16T     1%    /sapmnt/Q01
etc4sn1-stor:/export/etc4/APPSshare_Q01
                          16T       31K   16T     1%    /opt/sap
etc4sn1-stor:/export/etc4/trans
                          16T       31K   16T     1%    /opt/sap/trans
```

```
# tail -5 /etc/vfstab
# SAP file systems
etc4sn1-stor:/export/etc4/oracle      - /oracle      nfs - no
rw,bg,hard,nointr,rsize=131072,wsiz=131072,proto=tcp,vers=3,noac,suid
etc4sn1-stor:/export/etc4/sapmnt_Q01  - /sapmnt      nfs - no
rw,bg,hard,nointr,rsize=131072,wsiz=131072,proto=tcp,vers=3
etc4sn1-stor:/export/etc4/APPSshare_Q01 - /opt/sap     nfs - no
rw,bg,hard,nointr,rsize=131072,wsiz=131072,proto=tcp,vers=3
etc4sn1-stor:/export/etc4/trans      - /opt/sap/trans nfs - no
rw,bg,hard,nointr,rsize=131072,wsiz=131072,proto=tcp,vers=3
```

Mount at boot set to "no"

```
# clrt register ScalMountPoint

# clrs create -d -g scalmnt-rg -t ScalMountPoint -x MountPointDir=/oracle \
-x FileSystemType=nas \
-x TargetFileSystem=etc4sn1-stor:/export/etc4/oracle ora-fs-rs
# clrs create -d -g scalmnt-rg -t ScalMountPoint -x MountPointDir=/sapmnt/Q01 \
-x FileSystemType=nas \
-x TargetFileSystem=etc4sn1-stor:/export/etc4/sapmnt_Q01 sapmnt-fs-rs
# clrs create -d -g scalmnt-rg -t ScalMountPoint \
-x MountPointDir=/opt/sap/trans -x FileSystemType=nas \
-x TargetFileSystem=etc4sn1-stor:/export/etc4/trans trans-fs-rs
# clrs create -d -g scalmnt-rg -t ScalMountPoint \
-x MountPointDir=/opt/sap -x FileSystemType=nas \
-x TargetFileSystem=etc4sn1-stor:/export/etc4/APPSshare_Q01 apps-fs-rs
-p Resource_dependencies_offline_restart=usrsap-fs-rs trans-fs-rs
# clrg online -eM scalmnt-rg
# clrs status -g scalmnt-rg

=== Cluster Resources ===

Resource Name      Node Name      State      Status Message
-----
trans-fs-rs        iapps1        Online     Online
                   iapps2        Online     Online
                   iapps3        Online     Online
                   iapps4        Online     Online

sapmnt-fs-rs       iapps1        Online     Online
                   iapps2        Online     Online
                   iapps3        Online     Online
                   iapps4        Online     Online

ora-fs-rs          iapps1        Online     Online
                   iapps2        Online     Online
                   iapps3        Online     Online
                   iapps4        Online     Online

apps-fs-rs         iapps1        Online     Online
                   iapps2        Online     Online
                   iapps3        Online     Online
                   iapps4        Online     Online
```

SAP Setup

Step 11. Installing SAP

This section provides the steps to download, install and configure SAP ERP 6.0 Enhancement Package 5 on SPARC SuperCluster.

Important: The following instructions are provided as example. For the sake of simplicity, default values were accepted for most of the inputs during the installation. Appropriate values and selections should be used instead to match specific configuration requirements.

Regularly refer to SAP Note 1693680 “Running SAP Software on Oracle SPARC SuperCluster” and to SAP Note 724713 “Parameter Settings for Solaris 10” to get the latest information.

Before installing the SAP software, take the logical hosts up but not DEPRECATED, there are issues with some versions of sapinst. Use the command “ifconfig -a” to double-check. If it needs to be changed, logon to the global zone and run the command

```
ifconfig <interface> -deprecated up
```

After the SAP installation, the logical hosts can be set back to deprecated as required by Oracle Solaris Cluster.

After the SAP installation, verify that all the files and environment are identical on the zones in the same zone cluster.

11a) Requirements

Prior to starting the installation some Oracle Solaris groups and users need to be created and parameters and resources need to be set.

Add Oracle Solaris groups and users for the SAP installation

```
groupadd -g 1000 sapinst
groupadd -g 1001 sapsys
groupadd -g 1002 dba
groupadd -g 1003 oper
useradd -c "SAP System Administrator" -d "/export/home/qoladm" -u 1000 -s
"/bin/tcsh" -g sapsys -G dba,oper,sapinst -m qoladm
useradd -c "SAP Database Administrator" -d "/oracle/Q01" -u 1001 -s "/bin/tcsh" -g
dba -G sapinst,oper -m oraql
useradd -c "SAP System Administrator" -d "/export/home/sapadm" -u 1002 -s
"/bin/tcsh" -g sapsys -G sapinst -m sapadm
useradd -c "SAP System Administrator" -d /export/home/daadm -u 1004 -s
"/bin/tcsh" -g sapsys -G sapinst -m daadm
```

Set Oracle Solaris Parameters

Set the parameter according to SAP Note 724713.

If running Oracle Solaris 10 Update 10 (Solaris 10 8/11), do not set the "priv" level for process.max-file-descriptor. Use these following kernel parameters instead:

```
set pg_contig_disable=1
```

Add the project for SAP SID Q01:

```
projadd -p 222 -c "SAP System Q01" \
-U qoladm,oraqol,sapadm,daaadm \
-K "process.max-file-descriptor=(basic,65536,deny)" \
-K "process.max-sem-nsems=(priv,2048,deny)" \
-K "project.max-sem-ids=(priv,1024,deny)" \
-K "project.max-shm-ids=(priv,256,deny)" \
-K "project.max-shm-memory=(priv,18446744073709551615,deny)" Q01
```

In order to define the default project for the SAP system and the database administrator, add the following lines to file /etc/user_attr:

```
qoladm:::project=Q01
oraqol:::project=Q01
sapadm:::project=Q01
daaadm:::project=Q01
```

Set the resources for root

Before installing SAP, set resource settings for user root:

```
projmod -s \
-K "process.max-file-descriptor=(basic,65536,deny),(priv,65536,deny)" \
-K "process.max-sem-nsems=(priv,2048,deny)" \
-K "project.max-sem-ids=(priv,1024,deny)" \
-K "project.max-shm-ids=(priv,256,deny)" \
-K "project.max-shm-memory=(priv,18446744073709551615,deny)" \
user.root
```

As mentioned previously, when using Oracle Solaris 10 Update 10, do not use the priv level for process.max-file-descriptor.

After installing SAP, these resource settings for user root can be removed (default settings will apply afterwards):

```
projmod -r \
-K "process.max-file-descriptor=(basic,65536,deny),(priv,65536,deny)" \
-K "process.max-sem-nsems=(priv,2048,deny)" \
-K "project.max-sem-ids=(priv,1024,deny)" \
-K "project.max-shm-ids=(priv,256,deny)" \
-K "project.max-shm-memory=(priv,18446744073709551615,deny)" \
user.root
```

11b) Required software

Download SAP ERP 6.0 Enhancement Package 5

Download SAP ERP software from the SAP Software Download Center:

From the URL <http://service.sap.com/swdc> go to:

Installation and Upgrades → A-Z Index → E → SAP ERP → SAP ERP Enhance Package → EHP5 for SAP ERP 6.0 → Installation → DB System based on → ORACLE Database → based on SAP Netweaver 7.3

Download the following software:

- NW 7.3 Java based SW Comp.s Enablmt. (1 to 6)
- BS7i2010 Inst.mst. - NW 7.3 Enablmt. (1 to 8)
- BS7 UC-Kernel 7.20 Solaris on SPARC 64bit
- BS7i2010 Java - Enablement f. NW 7.3 (1 to 3)

Download the Oracle database

If using a ASFU license, download the Oracle Database from the SAP Software Download Center:

From the URL <http://service.sap.com/oracle-download> go to:

Oracle 11.2 Software (64-bit) → Installation → Solaris → ORACLE Database

Download the following software:

- ORACLE RDBMS 11.2.0.3 SOL. SPARC 64 (1 to 6)
- ORACLE Client 11.2.0.3

Installation locations

Install the software in the order shown below:

Preinstalled Software in the Database Tier (Database Domain)

- Oracle Database 11g Release 2 Server

In the Application Tier (Application Domain – Application Zone Cluster)

- SAP ERP 6.0 Enhancement Package 5

The present Installation Master DVD does not support the installation of the Oracle Client 11.2.x.x. As a workaround SAP provides a tool (`adaptDvd.sh`) to adapt the Installation Master, compare SAP Note 1642058. The tool is attached to the SAP Note.

Copy the Installation Master DVD to a local folder and apply the tool as following:

```
# sh adaptDvd.sh <path to your local installation master directory>
```

The present kernel DVD does not install the 720_EXT kernel that we chose to use in our example. As a workaround SAP provided SAP Note 1696716 – Creating a modified Solaris kernel medium.

Download the latest 720_EXT kernel files from the SAP Software Download Center.

From the URL <http://service.sap.com/swdc> go to:
 Support Packages and Patches → A-Z Index → SAP Kernel 64-Bit Unicode → SAP Kernel 720
 EXT 64-Bit UC → Solaris on SPARC 64bit → ORACLE

Download the following files:

- SAPEXEDB<release>.SAR
- DBATL720O10<release>.SAR

From → #Database Independent

Download the following file:

- SAPEXE<release>.SAR

Copy the kernel DVD to local folder and exchange the 720 kernel files by the 720_EXT kernel files:

```
# cp SAPEXEDB.SAR <local kernel dir>/DATA_UNITS/K_720_U_SOLARIS_SPARC/ORA/>
# cp DBATOOLS.SAR <local kernel dir>/DATA_UNITS/K_720_U_SOLARIS_SPARC/ORA/>
# cp SAPEXE.SAR <local kernel dir>/DATA_UNITS/K_720_U_SOLARIS_SPARC/DBINDEP/>
```

11c) SAP Installation

The option “High-Availability System” is required to install the following components on multiple logical hosts:

- ASCS Instance
- Database Instance
- Enqueue Replication Server Instance
- Central Instance
- Dialog Instance

In the following screenshots the SAP System ID “ERP” is used, the same steps should be followed using ID “QO1”.

Preparation

Log on as user root in a zone that belongs to scs-zc (i. e. escs1)

Set environment variable DISPLAY

Make sure that the logical host escs-lh is running in this zone. If not, start it with cluster command.

Make sure that the logical host escs-lh is not DEPRECATED, as there are known issues with some releases of sapinst. Use the command “ifconfig -a” to double-check. If it needs to be changed, logon to the global zone and run the command

```
ifconfig <interface> -deprecated up
```

Installation

Start the SAP Installer SAPINST in the directory for the Solaris SPARC OS on the Installation Master DVD. The logical hostname needs to be specified as a suffix:

```
# sapinst SAPINST_USE_HOSTNAME=escs-lh
```

Select the following option: Enhancement Package 5 for SAP ERP 6.0 → SAP Application Server ABAP → Oracle → High-Availability System → ASCS Instance

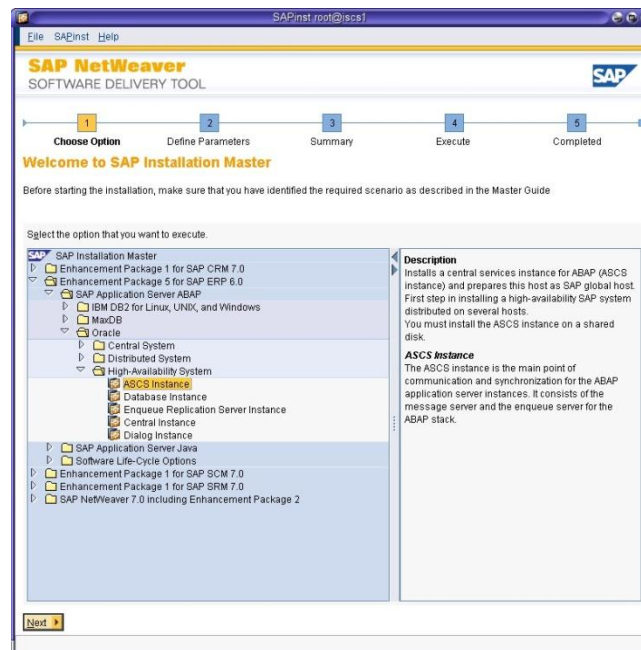

Select "ASCS Instance"

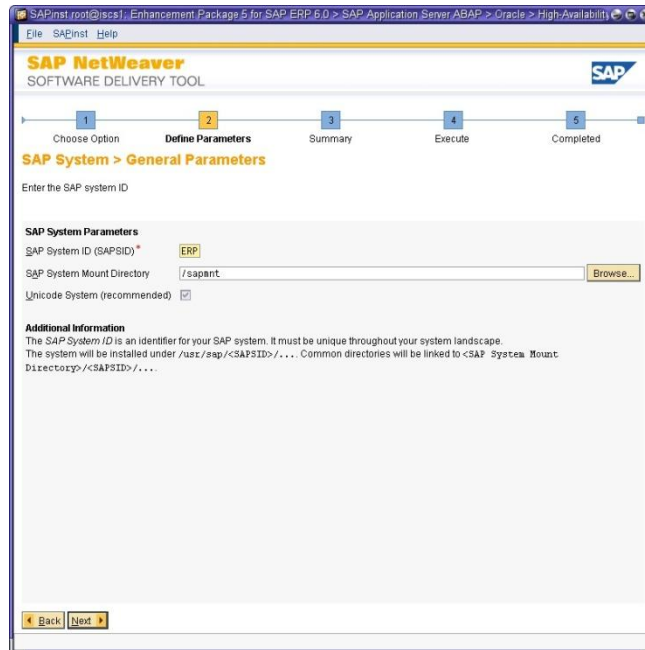

Define the SAP system parameters: Choose the SAP system ID.

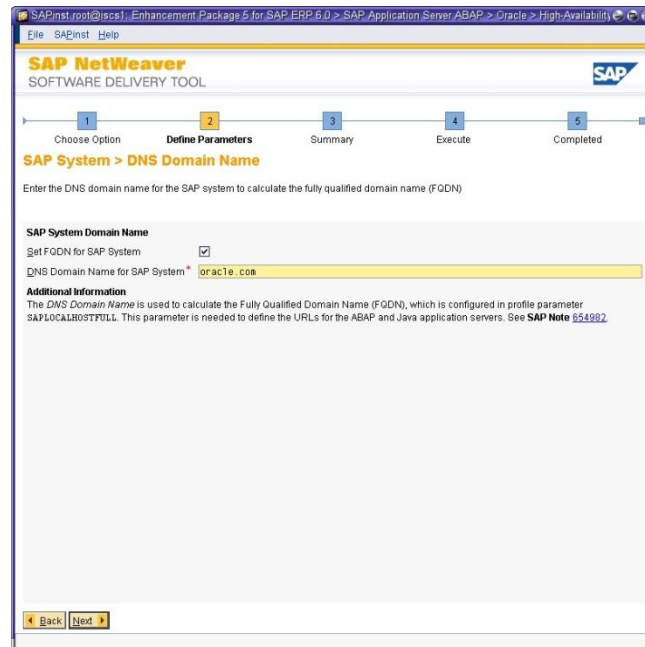

Enter the domain name if the installer is not able to detect it. The domain name should be set in the local file /etc/hosts prior to the installation.

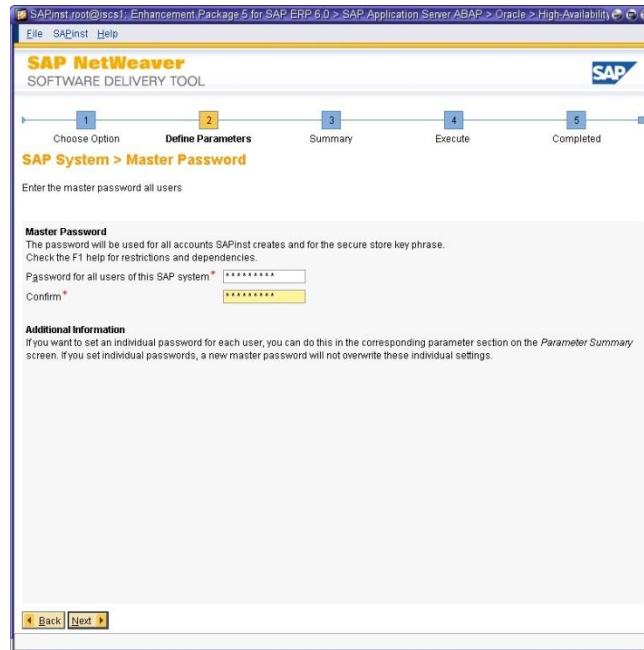

Enter the master password for all relevant accounts on operating system and application level.

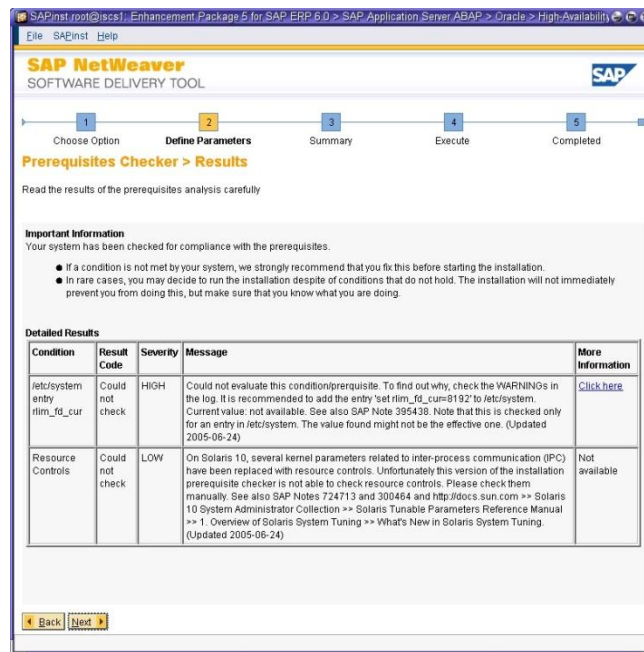

The prerequisite checker shows at least these two conditions that can be ignored. The parameter rlim_fd_cur was already set as a project parameter but the prerequisite checker expects it explicitly in the file /etc/system. Click “Next”.

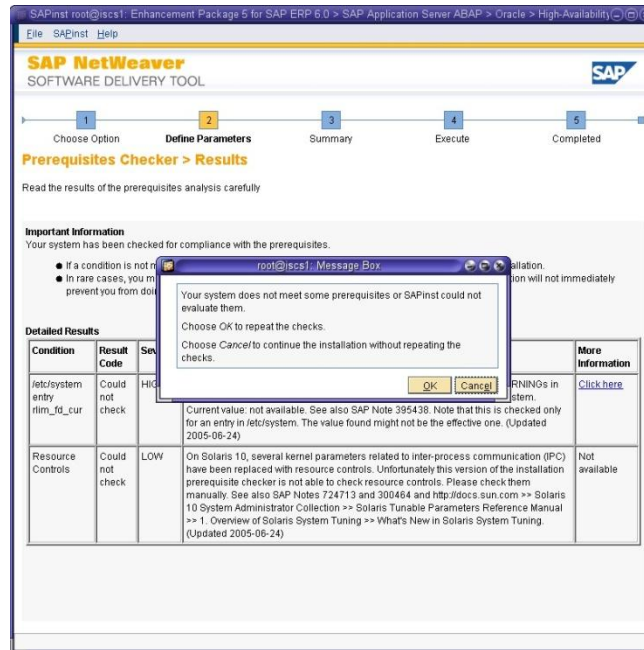

Click “Cancel” to continue the installation without repeating the checks.

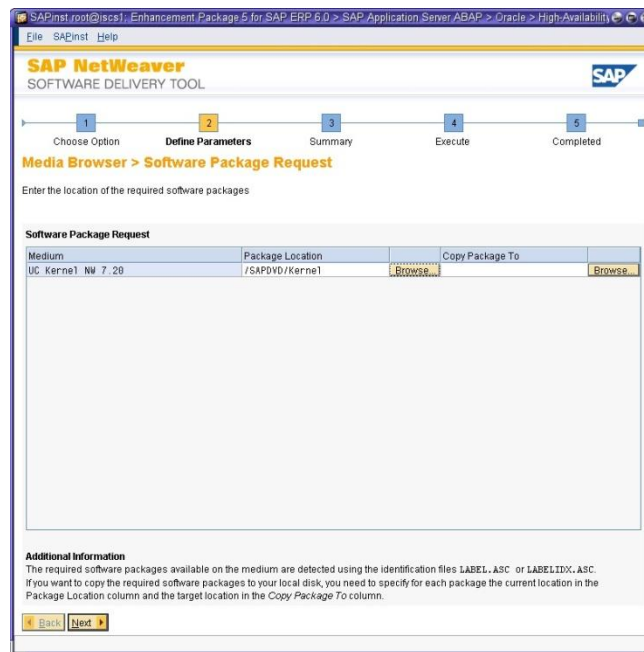

Indicate the location of the kernel DVD.

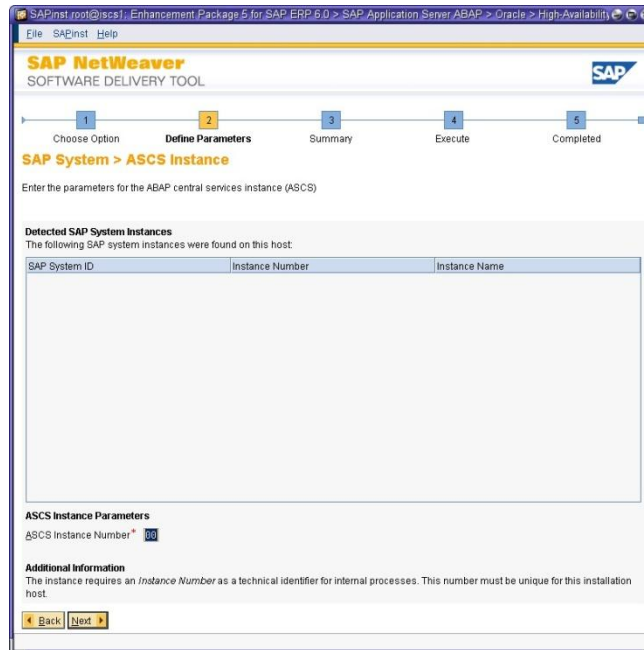

The ASCS instance will be deployed by default as with instance number “00”.

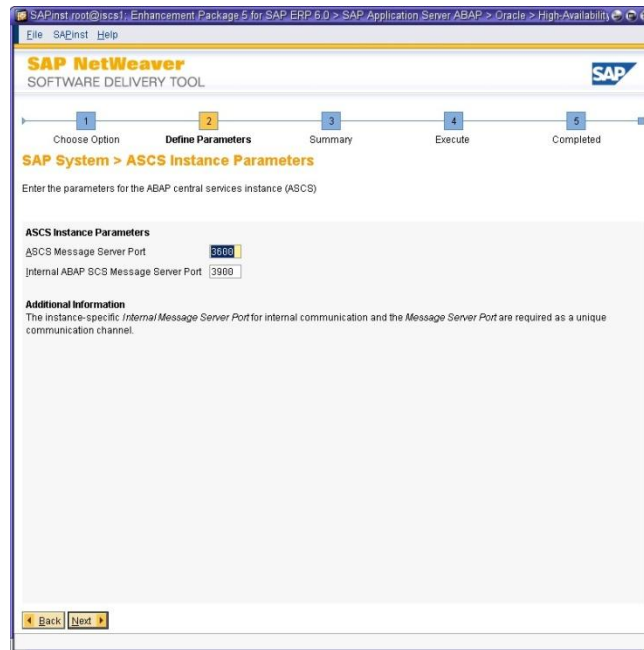

Ensure that the ports to be set for the message server are not already used by another application.

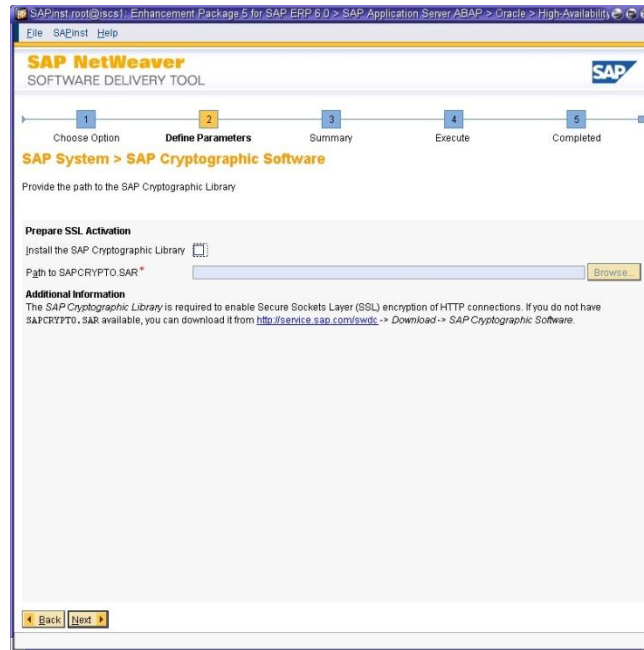

This option allows installing the SAP cryptographic library if needed. The files can be found on <http://service.sap.com/swdc>

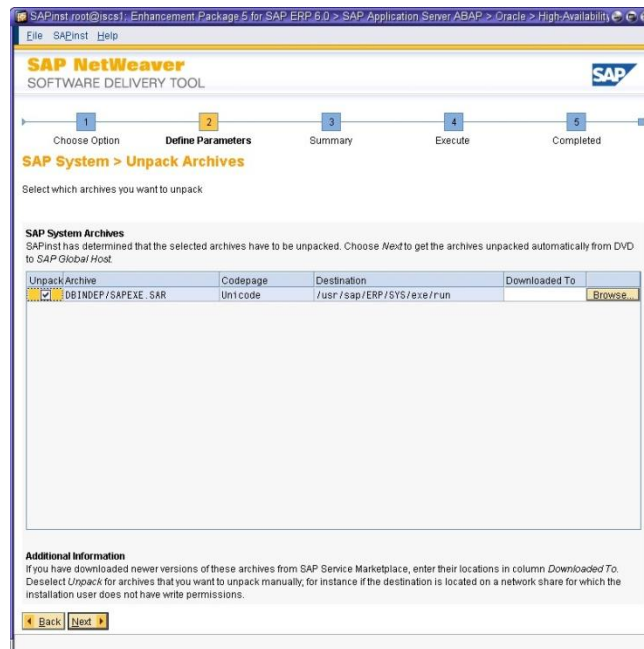

Leave the defaults to unpack the archive to the proposed destination.

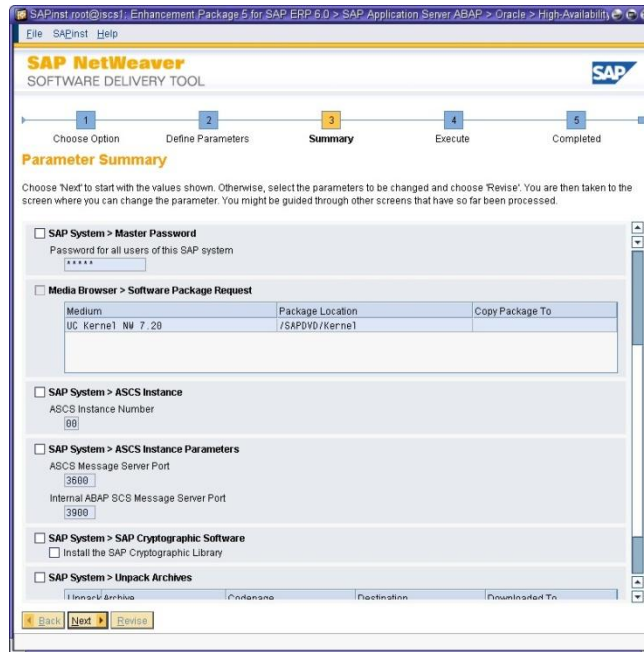

This summary lists the parameters provided. A parameter can be selected and modified if needed. Click “Next” to start the installation.

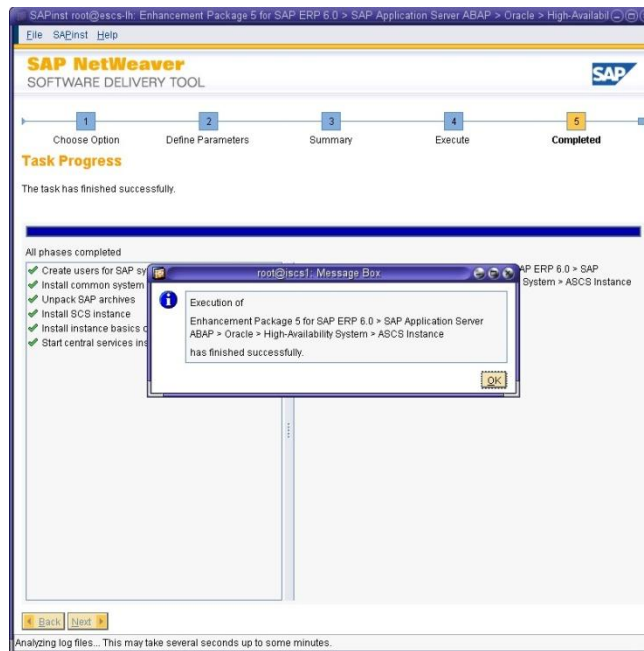

After a successful installation a confirmation message box is displayed. Click “OK”.

11d) Installation of the Oracle 11.2.0.3 Database software

Preparation

Log on as user root in a zone that belongs to sapdev-zc, (i.e. esapdev1). The Oracle Database will be temporarily installed in this zone during the SAP installation. After the whole SAP system is installed, the Oracle Database will be migrated to Oracle RAC and ASM in its own Oracle Solaris 11 LDOM.

Set the environment variable DISPLAY

Make sure that the logical host esapdb-lh is running in this zone. If not, start it with cluster command.

Make sure that the logical host esapdb-lh is not DEPRECATED, as there are known issues with some releases of sapinst. Use the command “ifconfig –a” to double-check. If it needs to be changed, log to the global zone and run the command

```
ifconfig <interface> -deprecated up
```

Installation

Start the SAP Installer SAPINST in the directory for the Solaris SPARC OS on the Installation Master DVD. The logical hostname needs to be specified as a suffix:

```
# sapinst SAPINST_USE_HOSTNAME=esapdb-lh
```

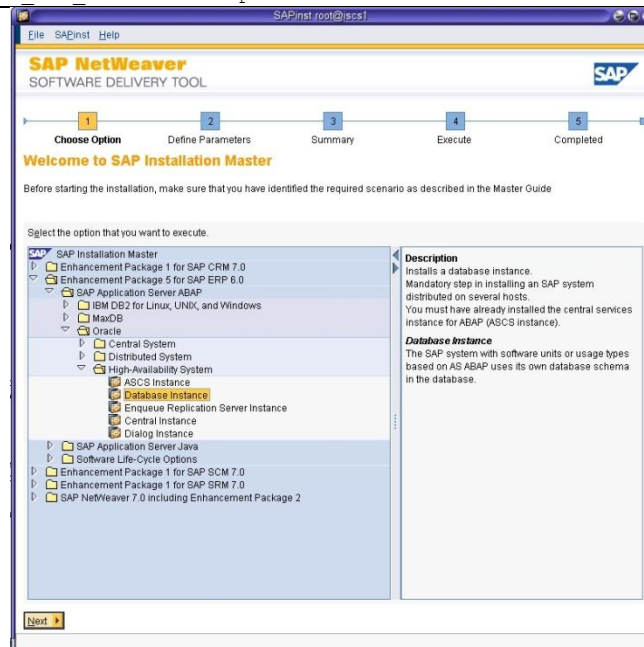

Select the following option: Enhancement Package 5 for SAP ERP 6.0 → SAP Application Server ABAP → Oracle → High-Availability System → Database Instance

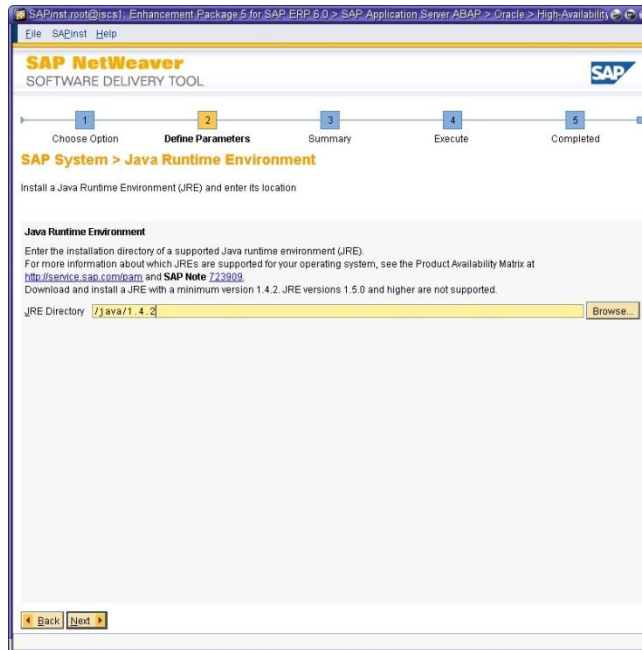

Indicate the location of the installed Java 1.4.2 instance.

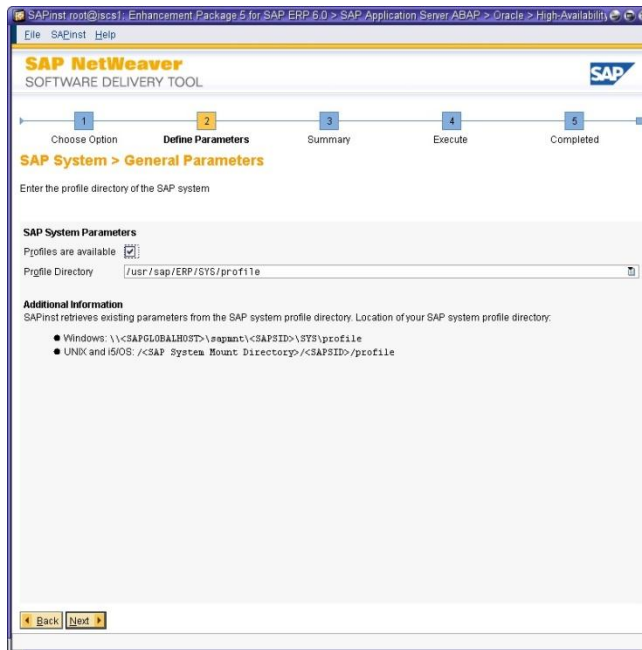

Use the default profile directory.

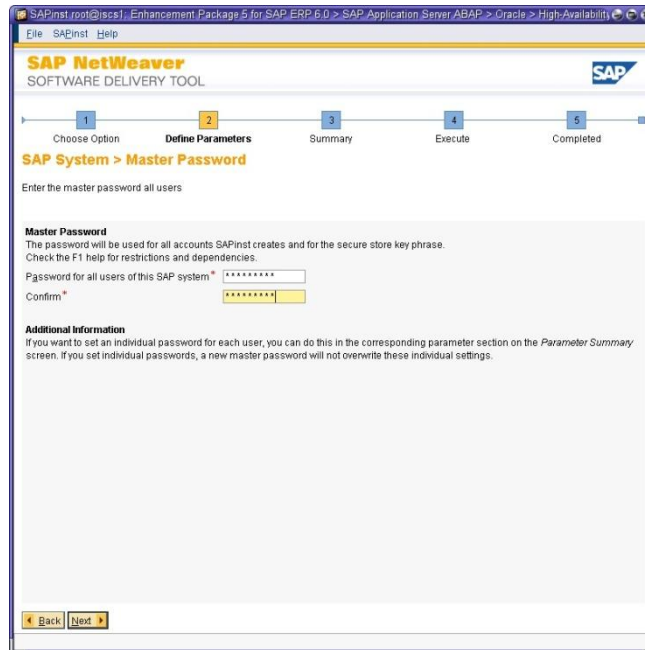

Enter the master password for all users.

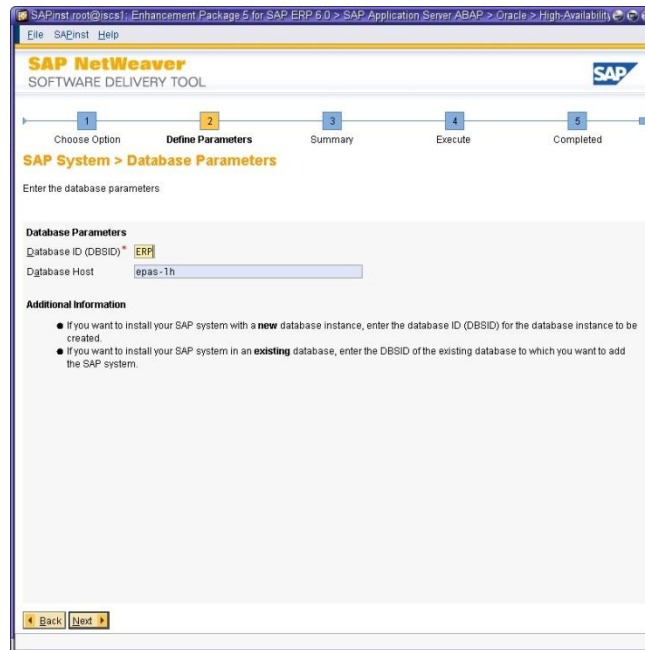

Enter the database ID and esapdb-1h as the database host.

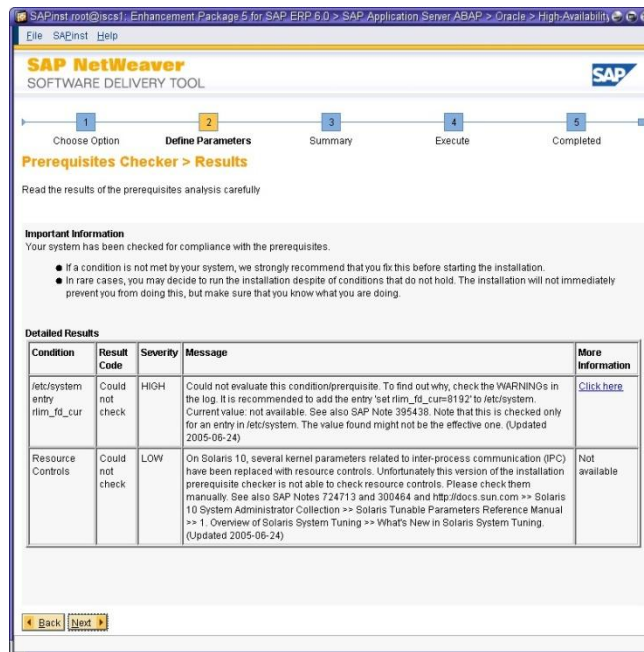

Review the results of the prerequisite checker.

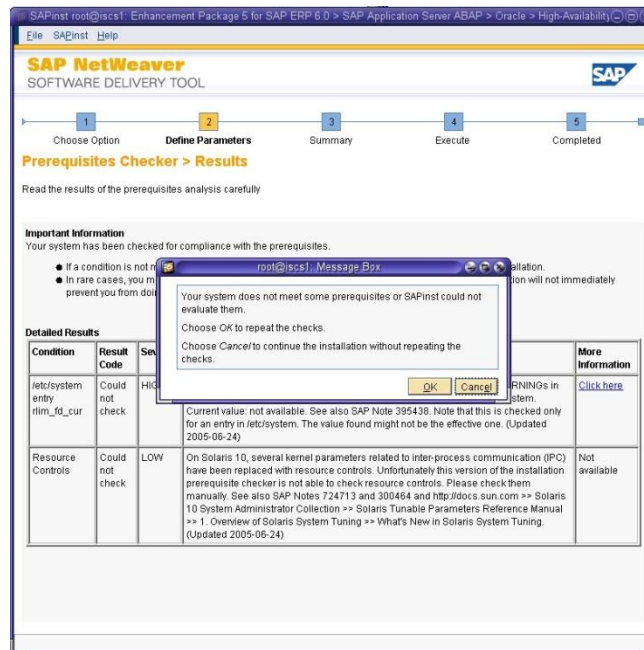

Click “Cancel” to continue the installation.

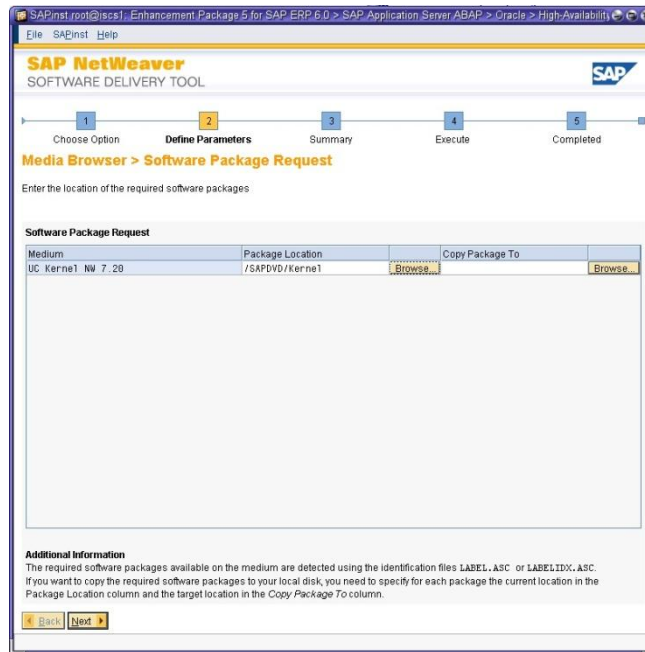

Indicate the location of the kernel DVD.

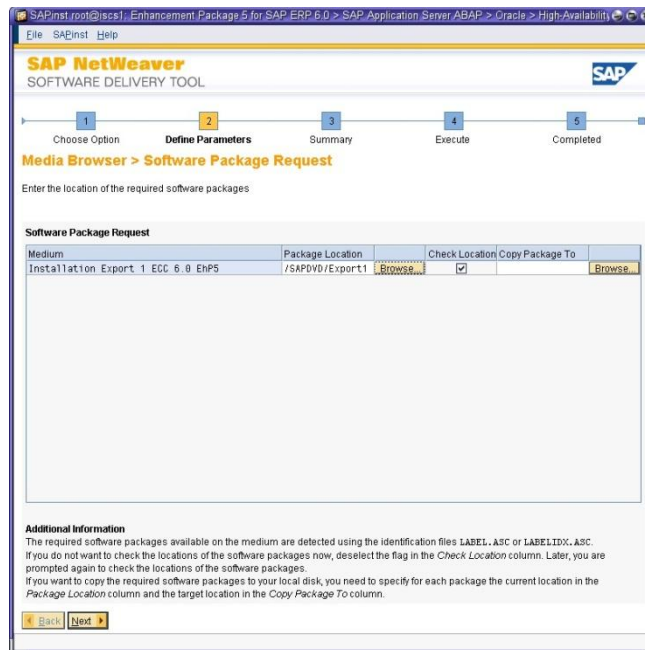

Indicate the location of the DVD: Installation Export 1 ECC 6.0 EHP5.

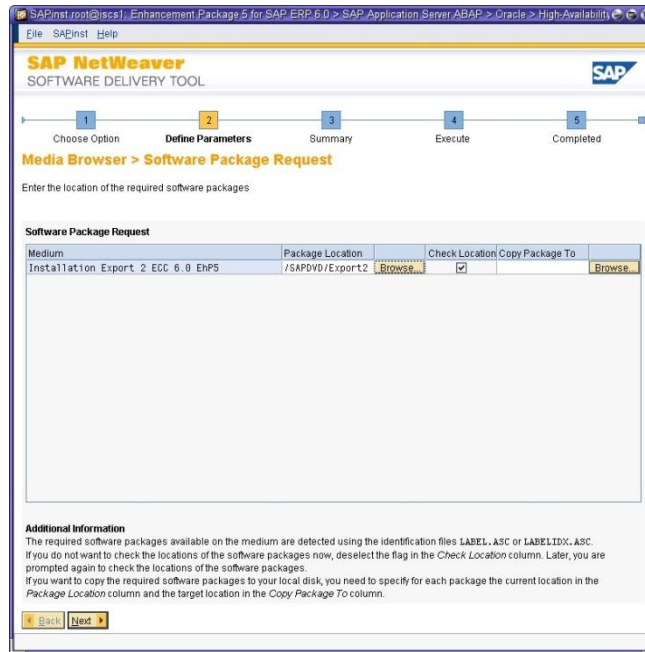

Indicate the location of the DVD: Installation Export 2 ECC 6.0 EHP5.

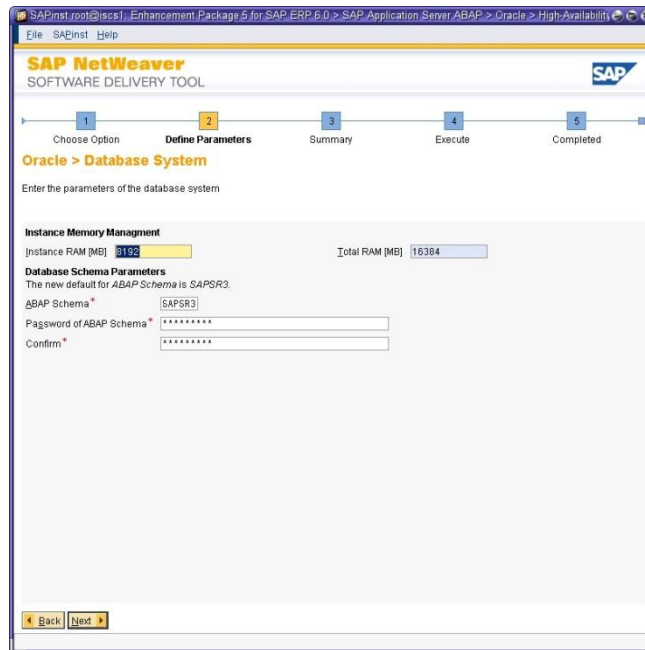

Enter the amount of instance memory for the Oracle database.

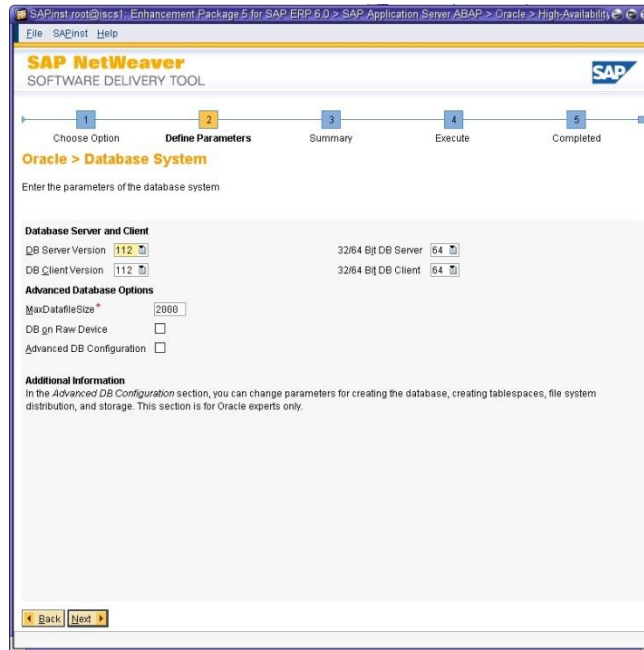

Select DB version “112” and “64” bit for DB server and client.

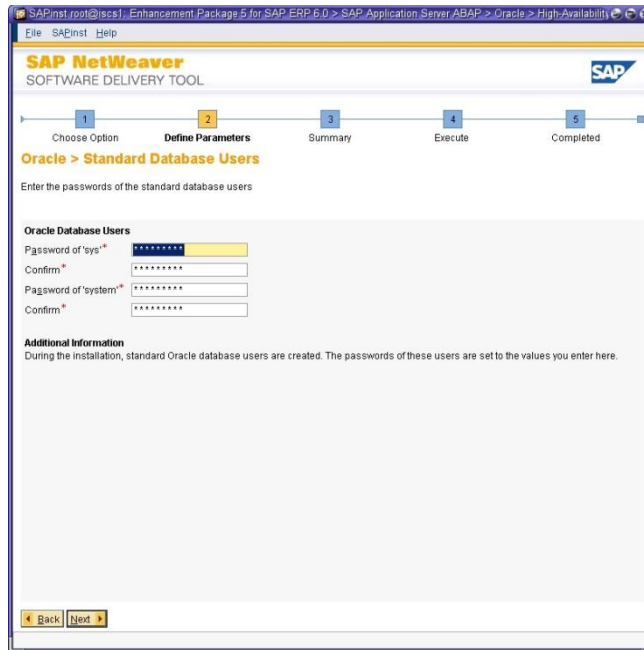

Set the passwords for the Oracle database users.

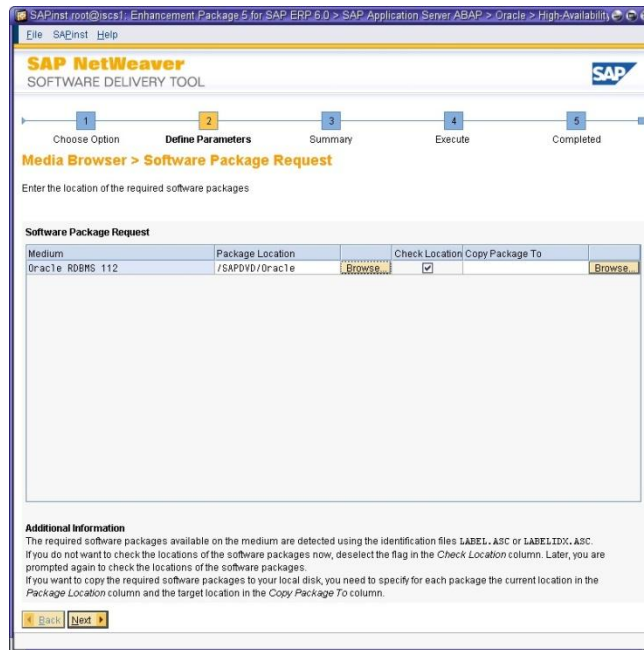

Indicate the location of the Oracle database RDBMS DVD.

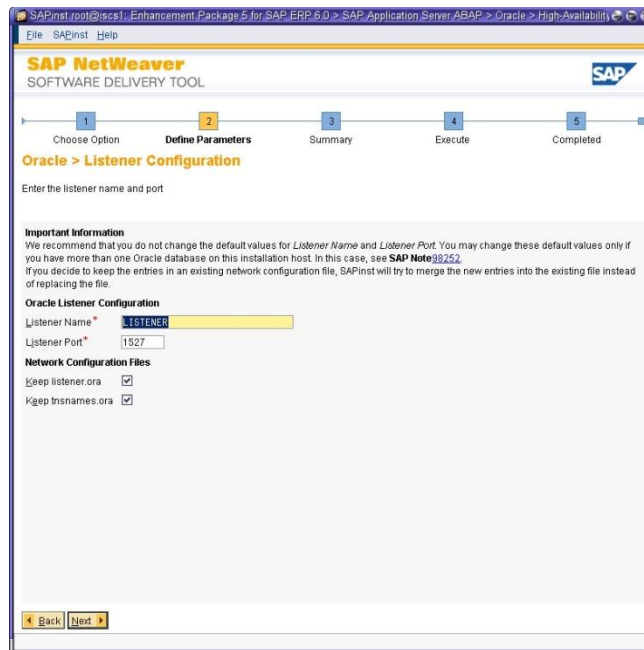

The defaults for the Oracle listener can be accepted if port 1527 is available.

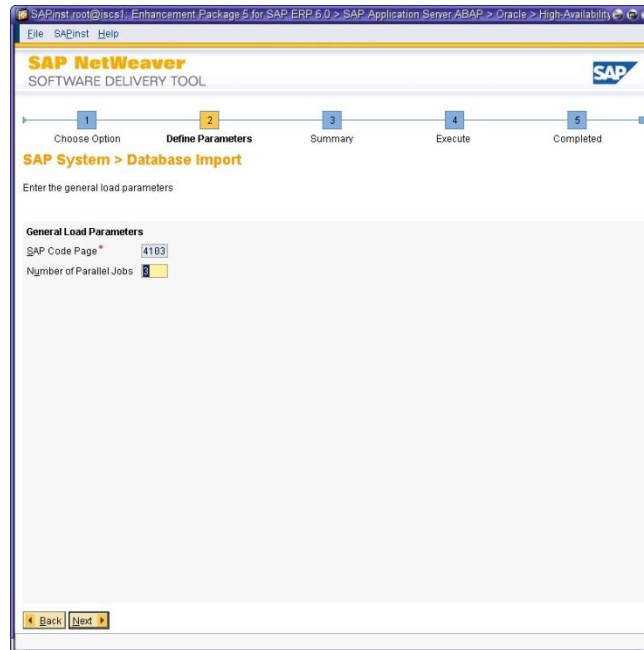

Accept the defaults for the Database load parameters.

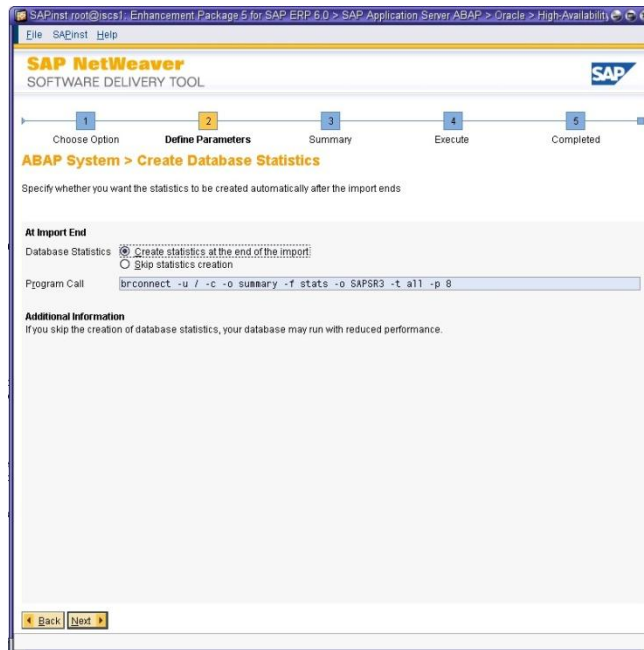

Select “Create statistics at the end of the import” and do not change the entry for Program Call.

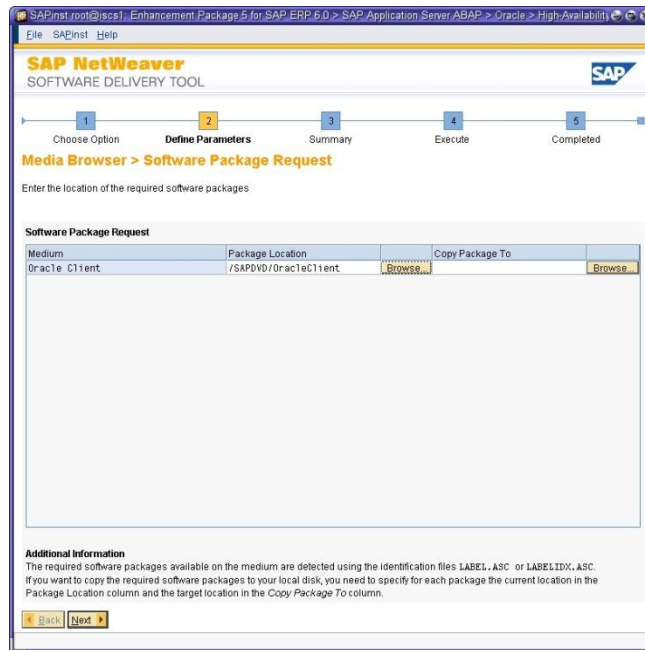

Indicate the location for the Oracle client DVD.

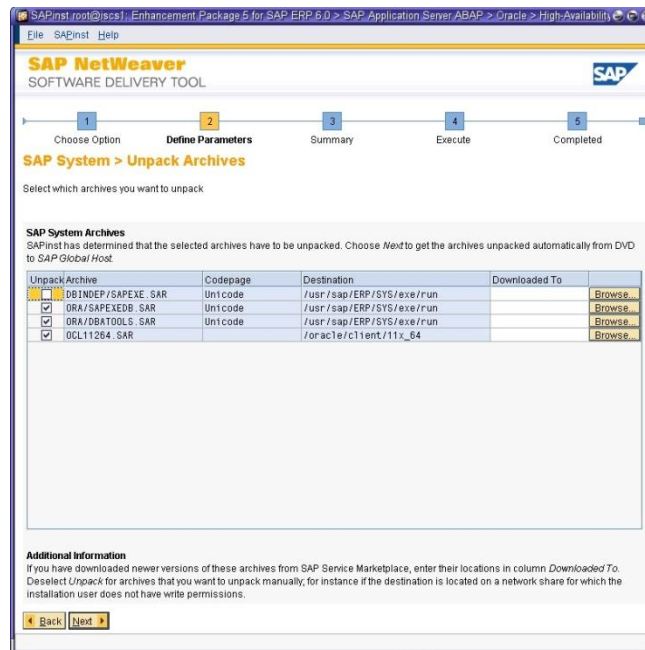

Leave the defaults to unpack the archives.

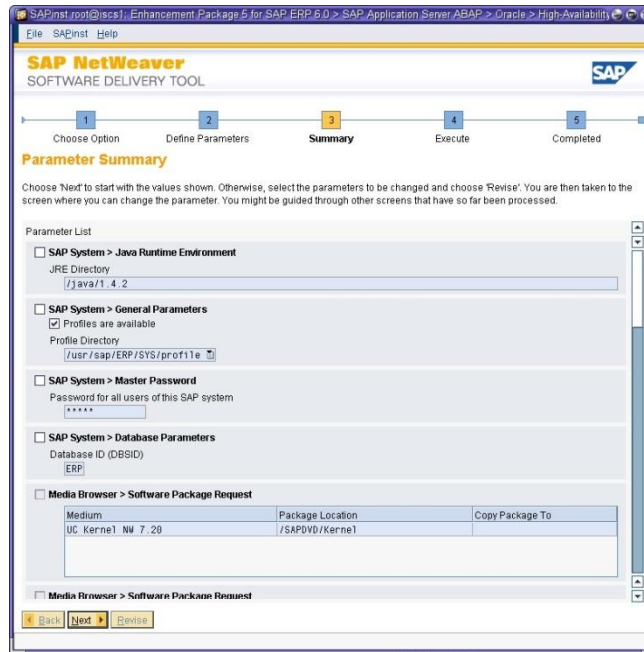

This summary lists the parameters provided. A parameter can be selected and modified if needed. Click “Next” to start the installation.

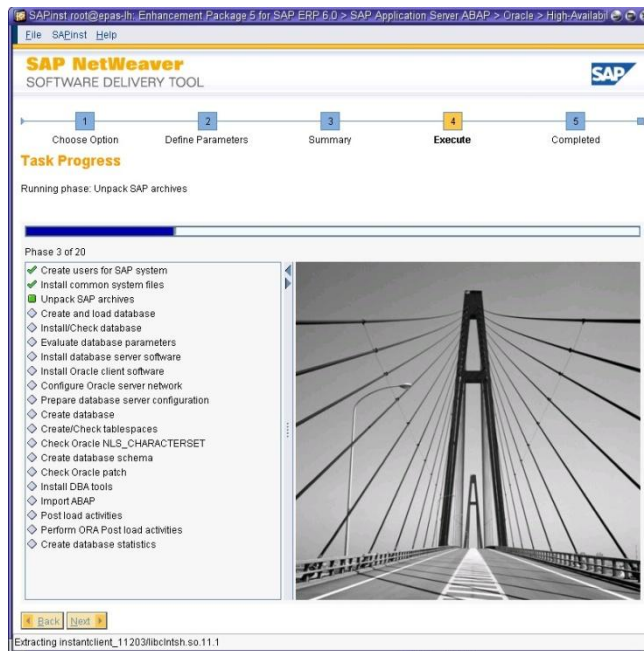

The installer prepares the Oracle database installation.

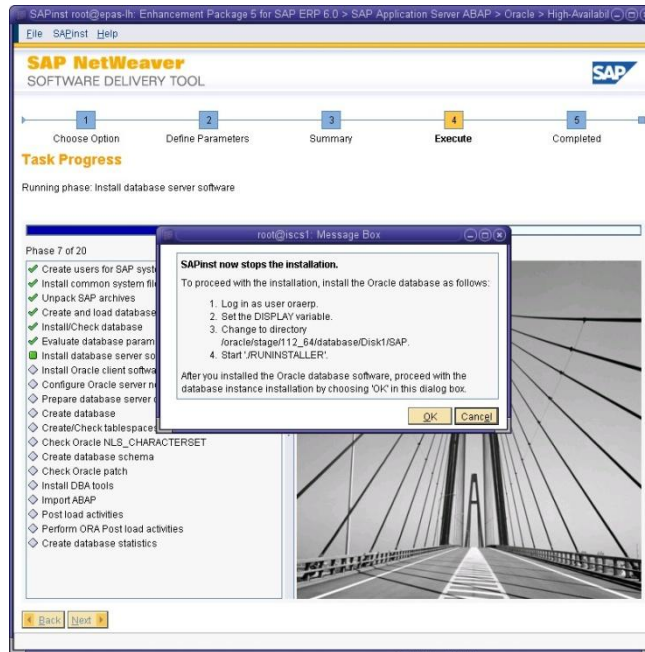

The installer stops for the installation of the Oracle database. Follow the instructions in the message box to start the Oracle “RUNINSTALLER”.

Installation of the Oracle database

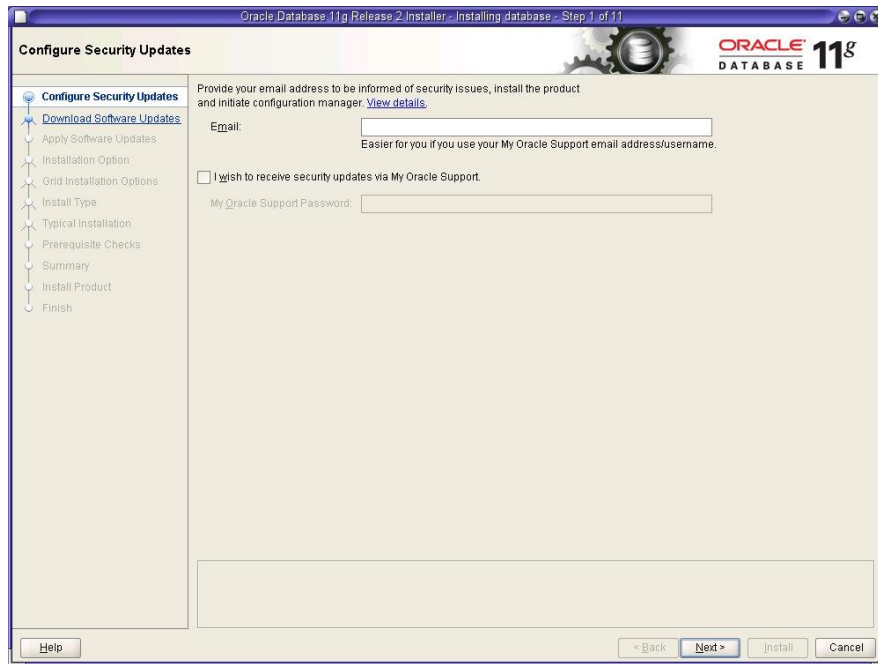

Insert a valid email address and your password for “My Oracle Support” to receive communications about security updates.

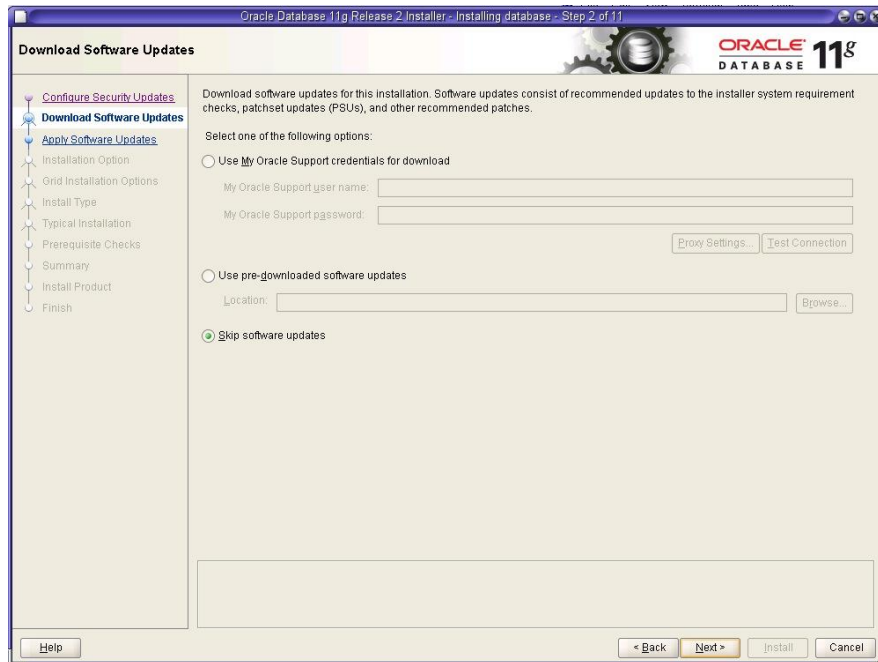

Select an option to download software updates. In our example we choose "Skip software updates".

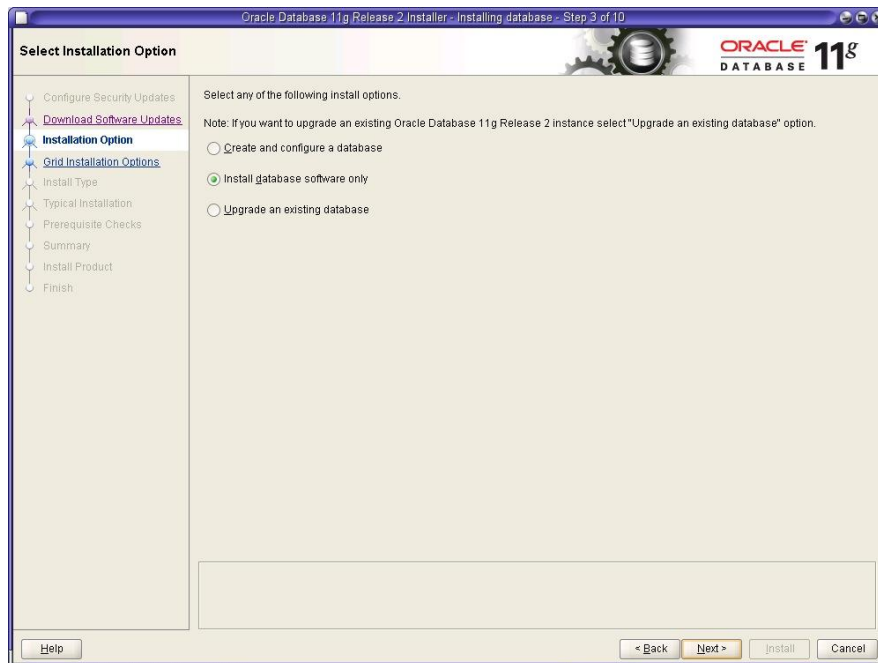

Use the default option "Install database software only".

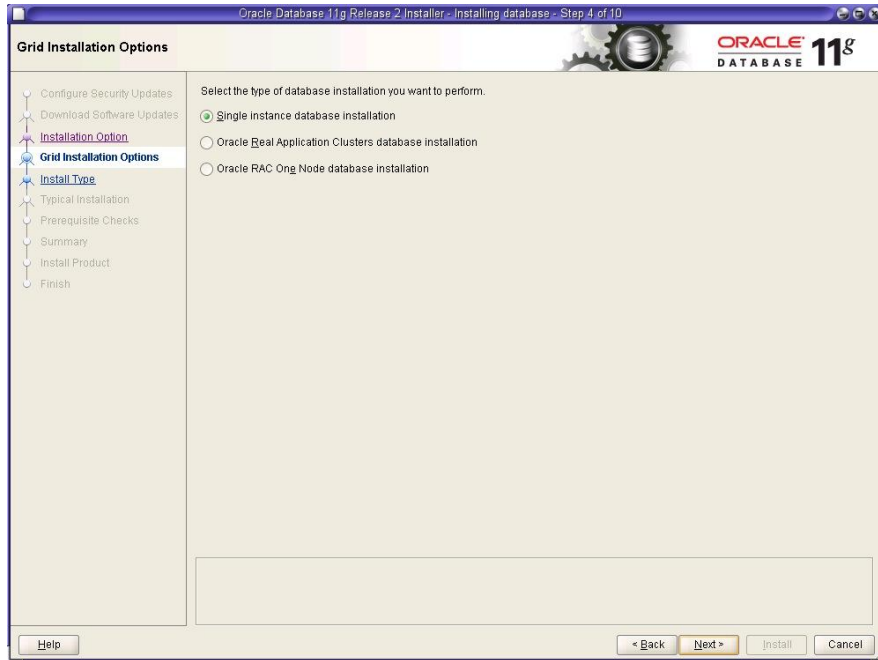

Use the default option “Single instance database installation”.

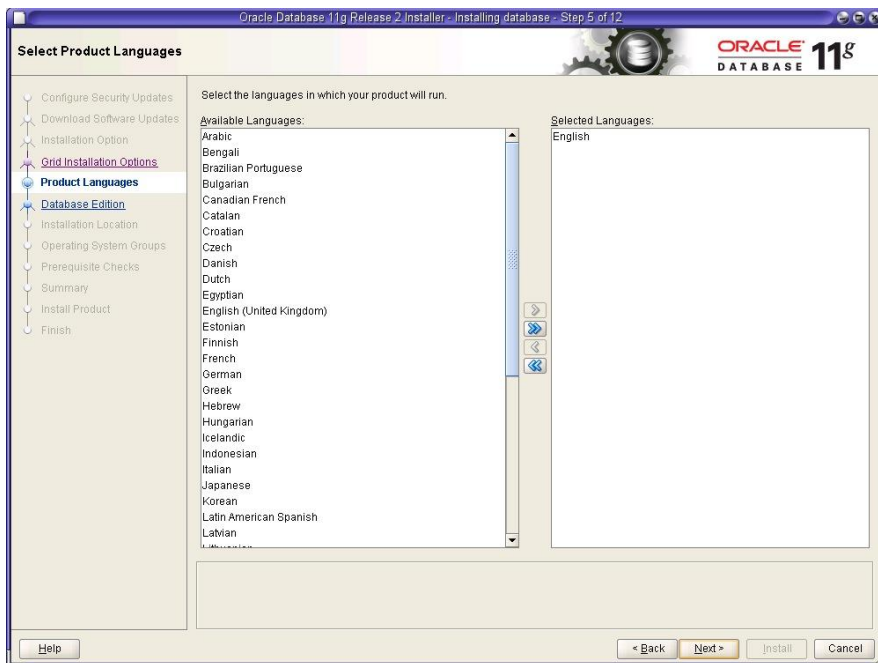

Install additional languages if necessary.

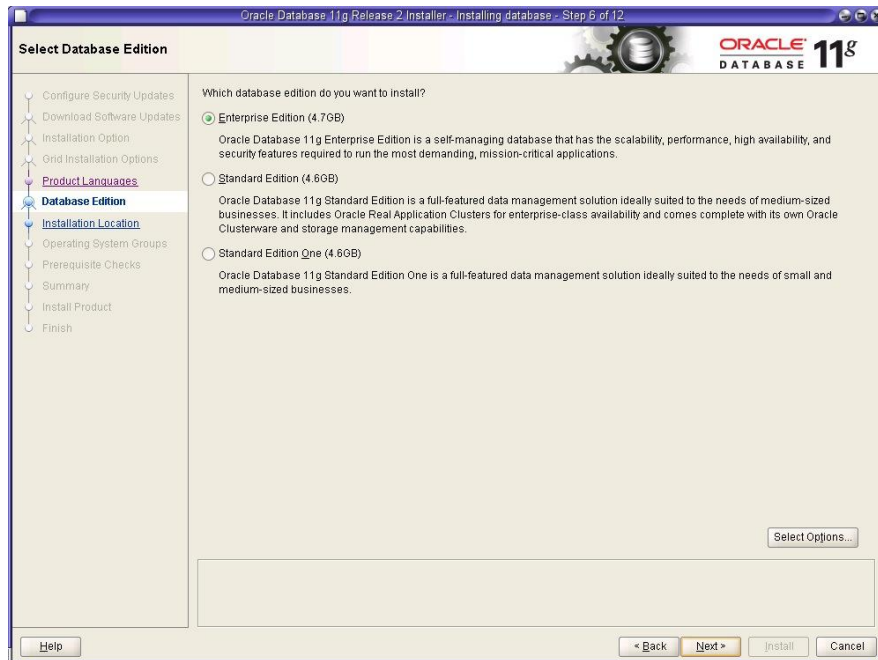

Use the default to install the Enterprise Edition of the Oracle Database.

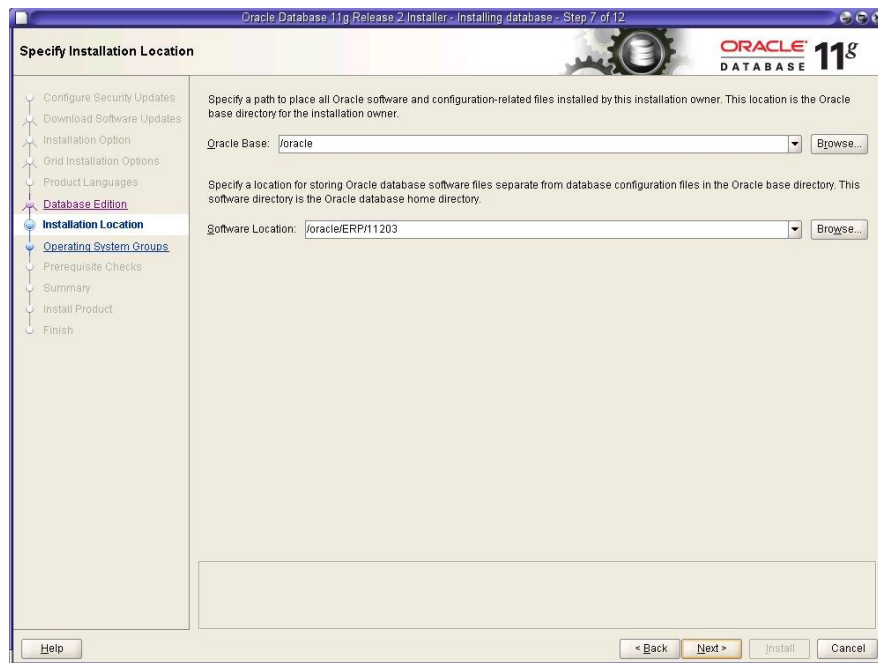

Keep the default installation locations.

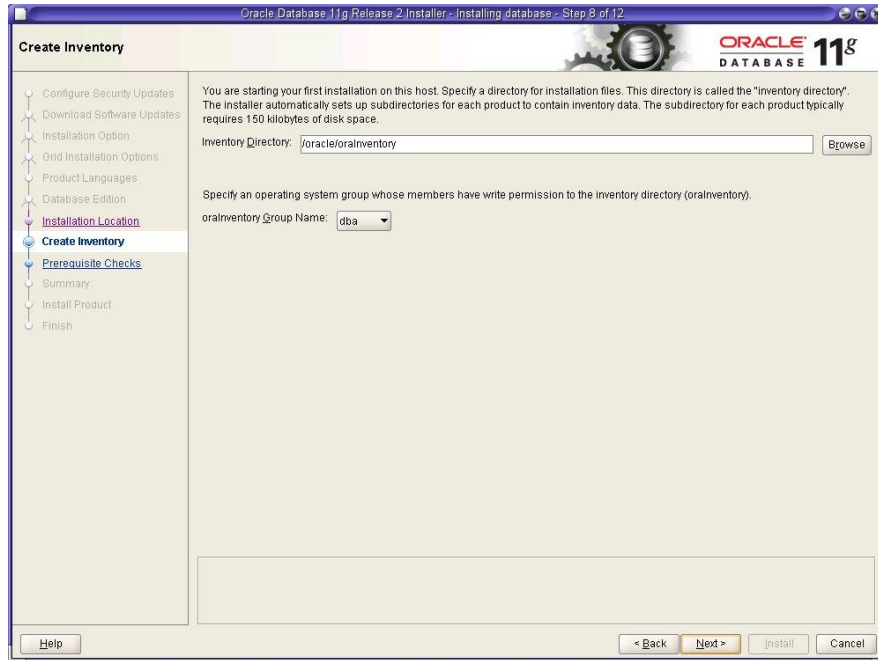

Leave the defaults for the inventory directory.

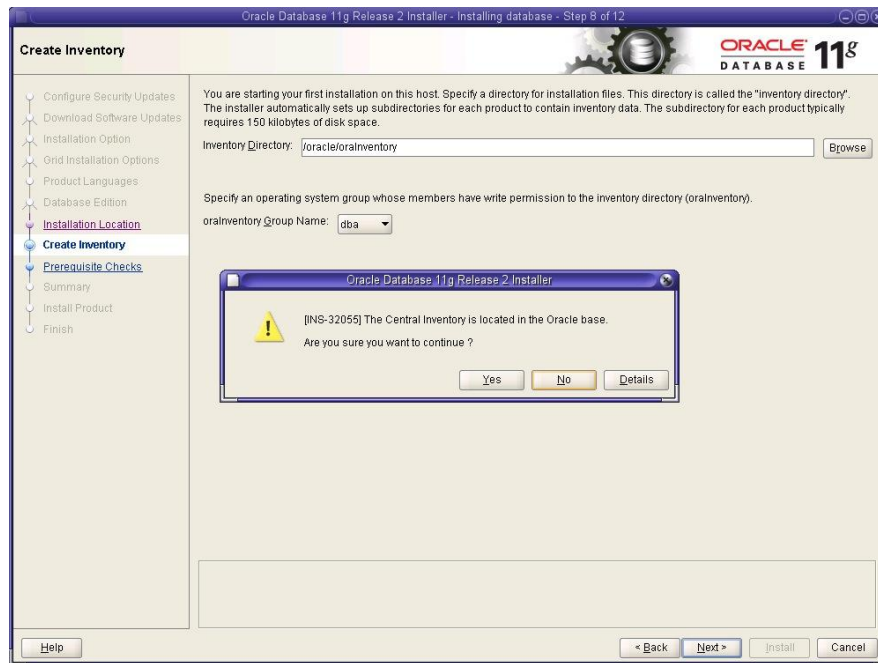

Click “Yes” to confirm the warning to install the inventory directory in /oracle.

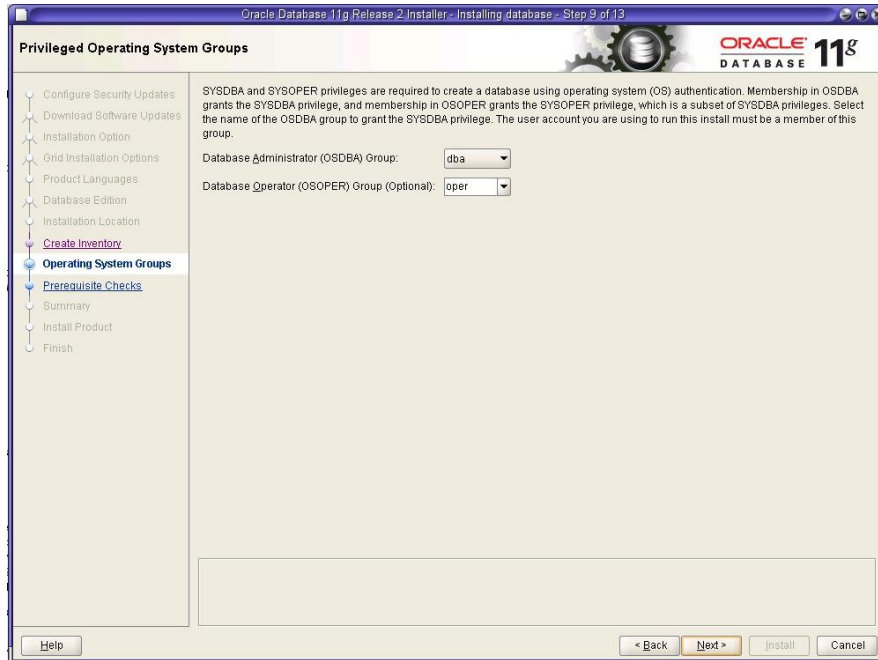

Keep the default group names.

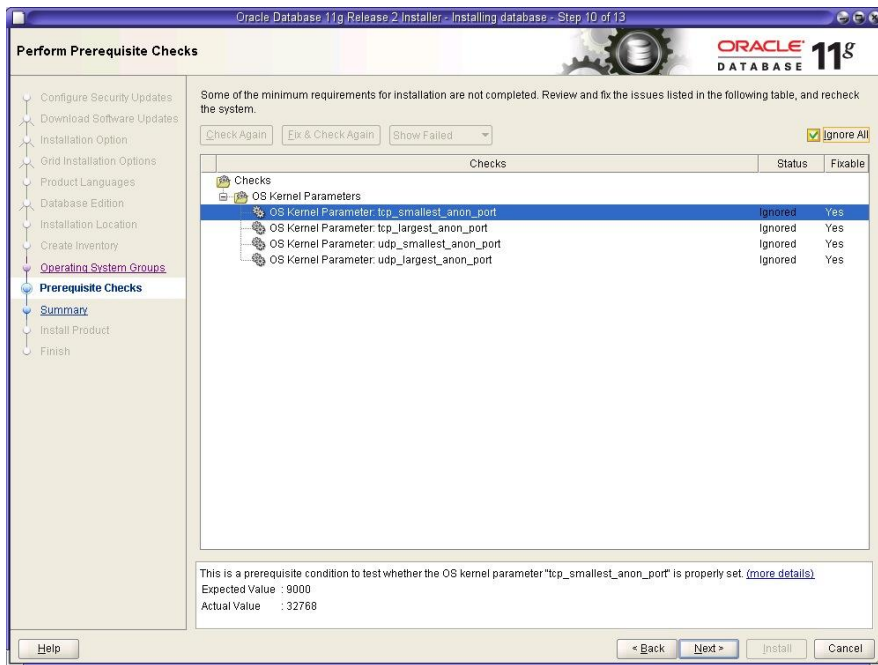

During the installation, the warnings related to the Oracle Solaris kernel parameters can be ignored.

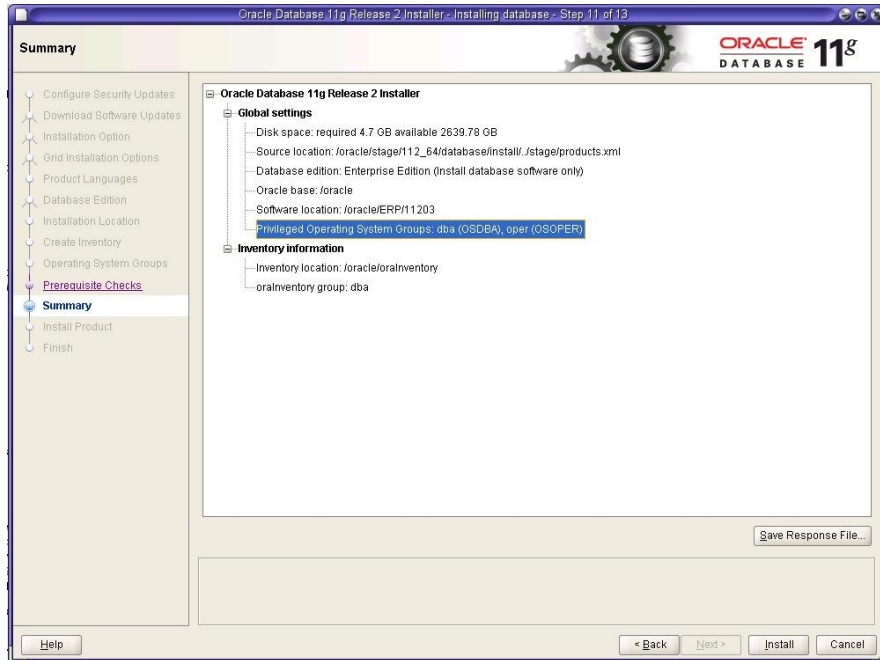

Click “Install” to start the installation process.

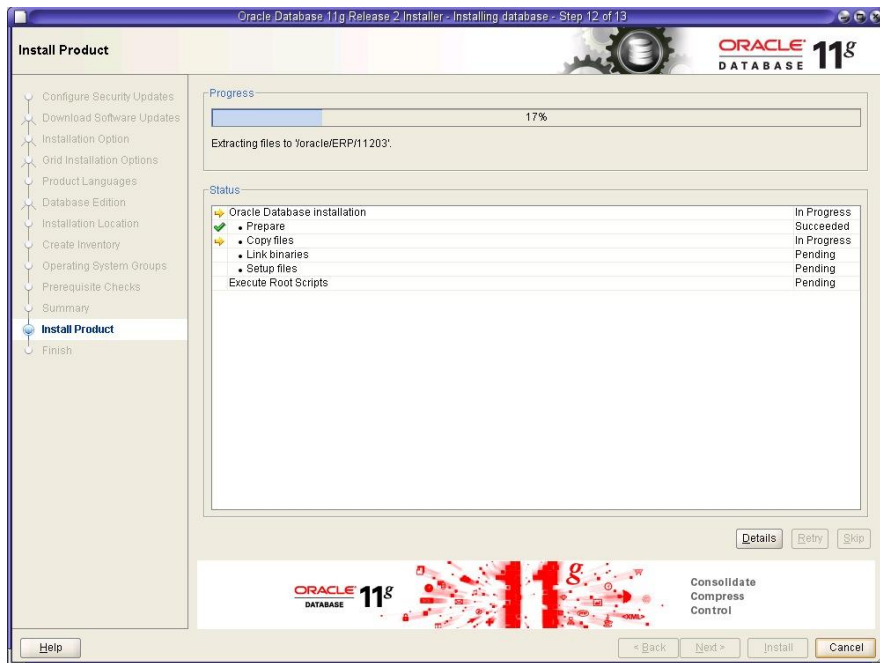

Installation process.

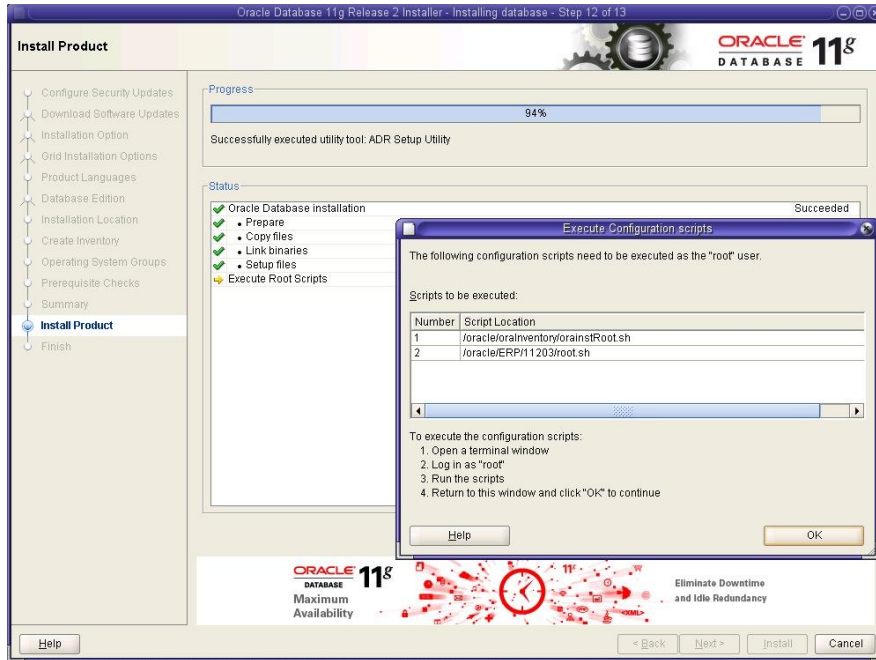

Follow the instructions to execute configuration scripts as the root user.

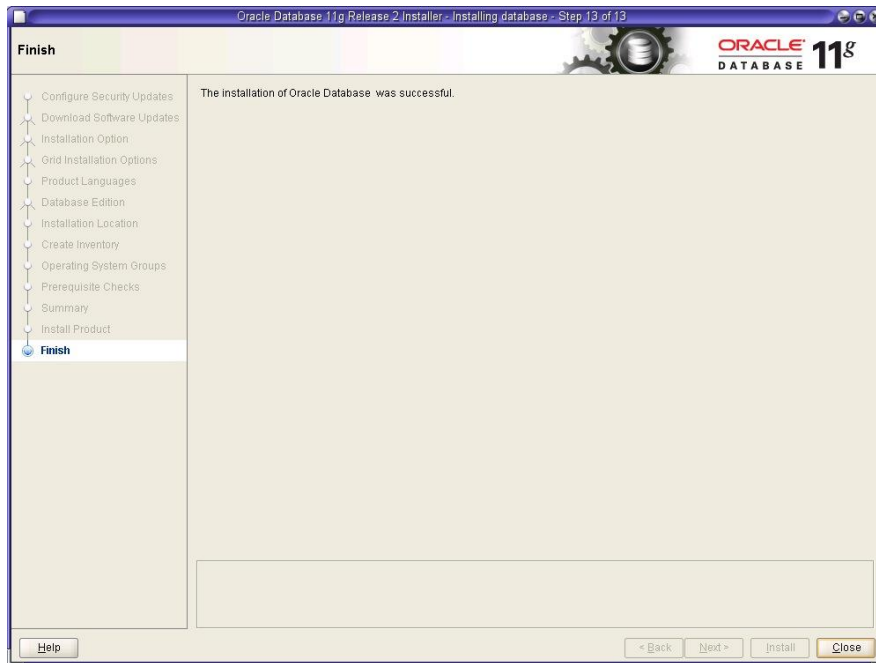

After a successful installation, the message “The installation of Oracle Database was successful” appears. Click “Close” to complete the installation process.

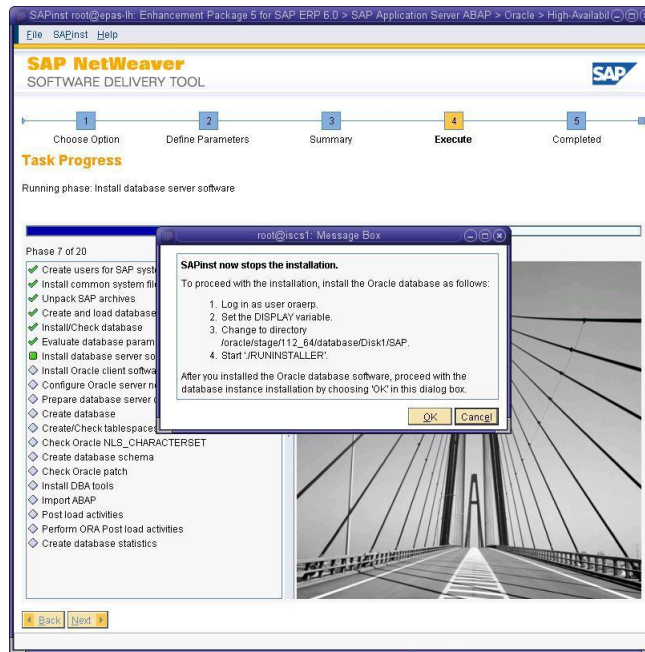

After installing the Oracle Database software, proceed with the database instance installation by choosing “OK” in the dialog box.

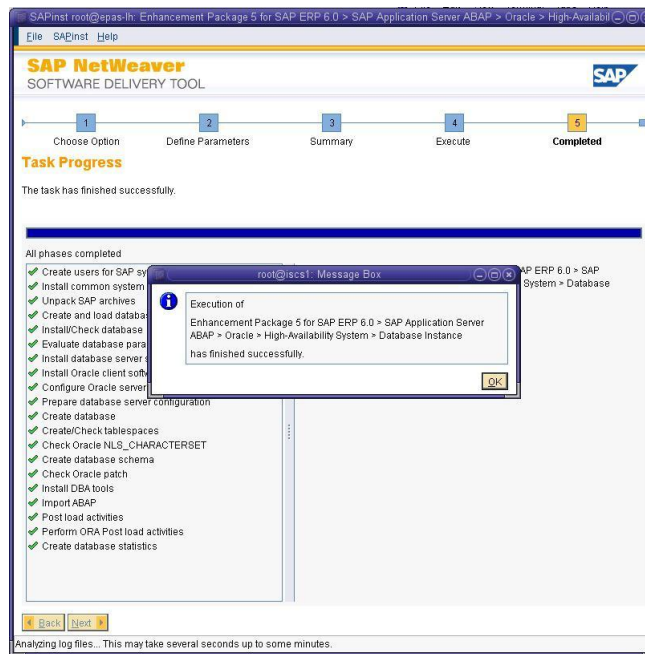

After a successful installation a confirmation message box is displayed. Click “OK”.

11e) Installation of the Enqueue Replication Server Instance

The next step is the installation of the Enqueue Replication Server Instance. Logon to the host erep-lh and start the SAP Installer SAPINST in the directory for the Solaris SPARC OS on the Installation Master DVD. The logical hostname needs to be specified as a suffix:

```
# sapinst SAPINST_USE_HOSTNAME=erep-lh
```

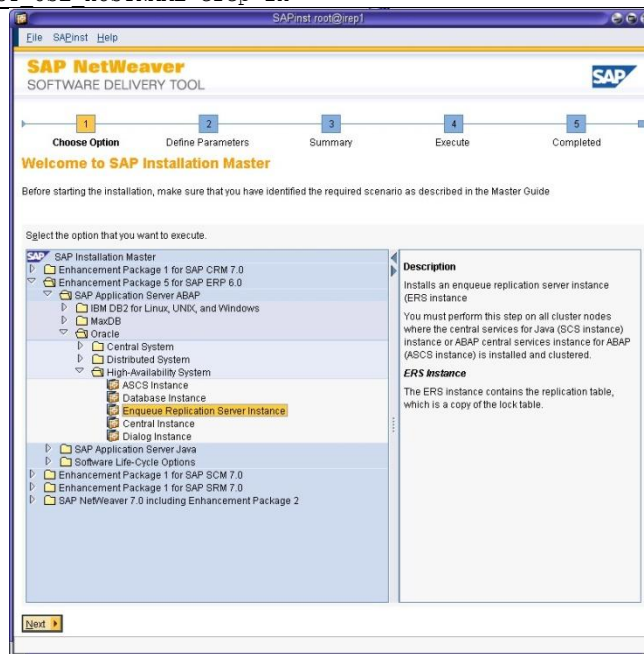

Select the following option: Enhancement Package 5 for SAP ERP 6.0 → SAP Application Server ABAP → Oracle → High-Availability System → Enqueue Replication Server Instance.

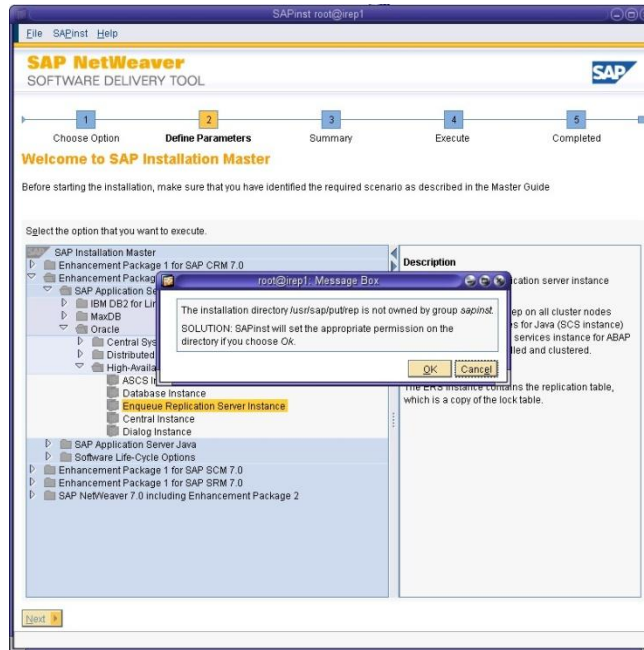

SAPINST sets the appropriate ownership permissions for the work directory. Accept the changes.

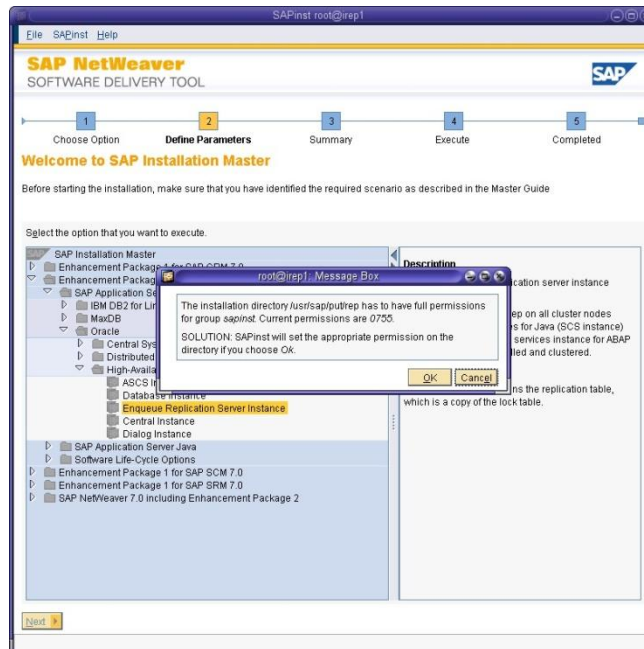

SAPINST sets the appropriate access permissions for the work directory. Accept the changes.

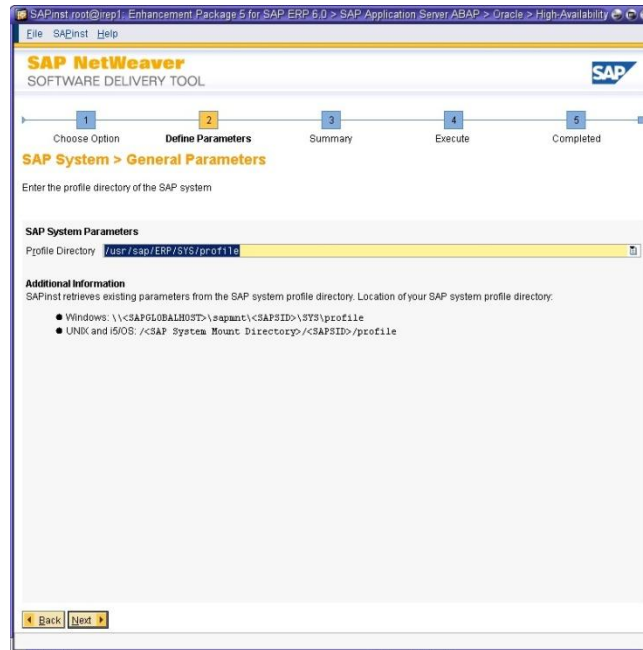

Keep the default location for the SAP system profile directory.

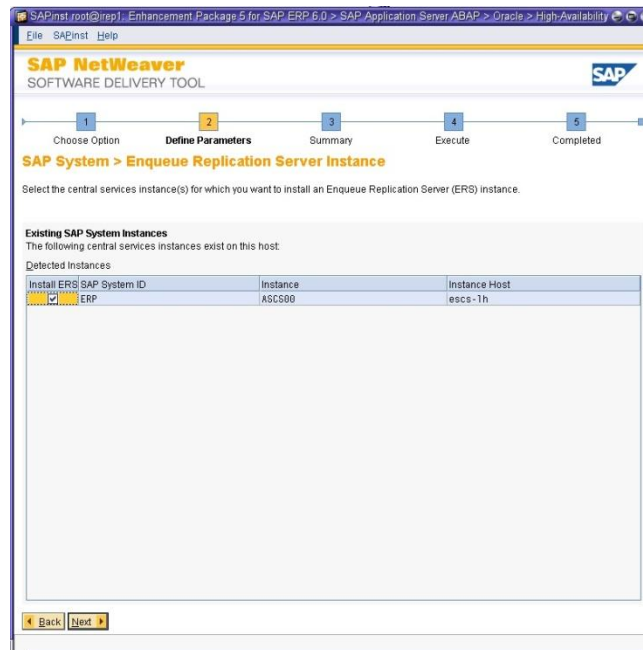

Select the existing SAP system central services instance.

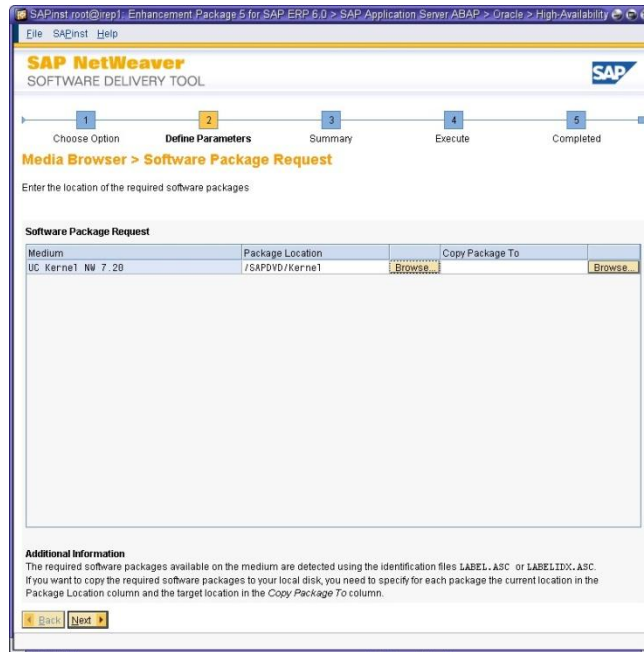

Indicate the location of the kernel DVD.

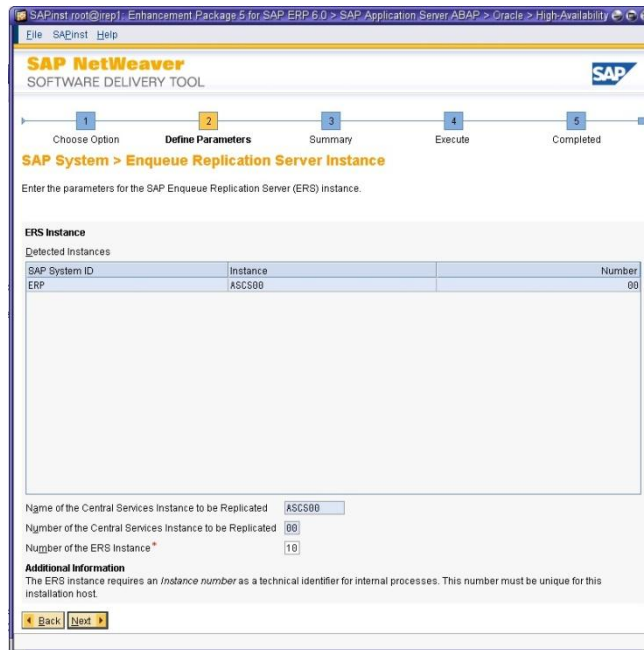

Select the number of the ERS instance. The default can be accepted.

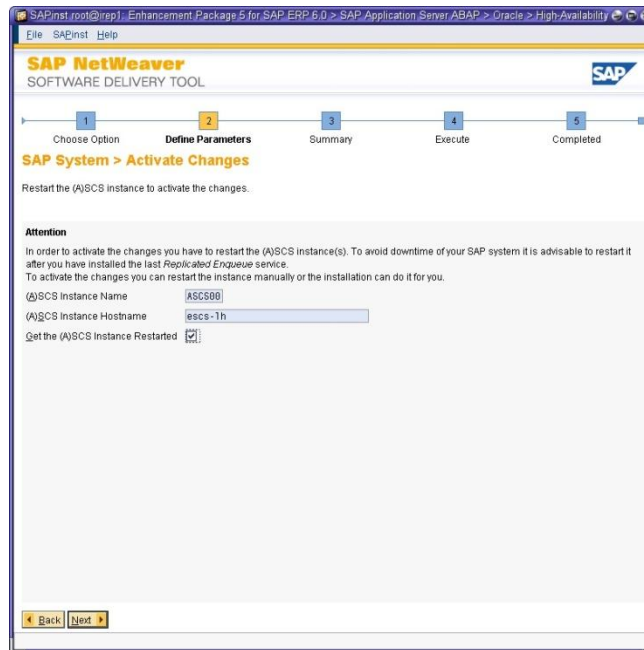

Check the box “Get the (A)SCS Instance Restarted”.

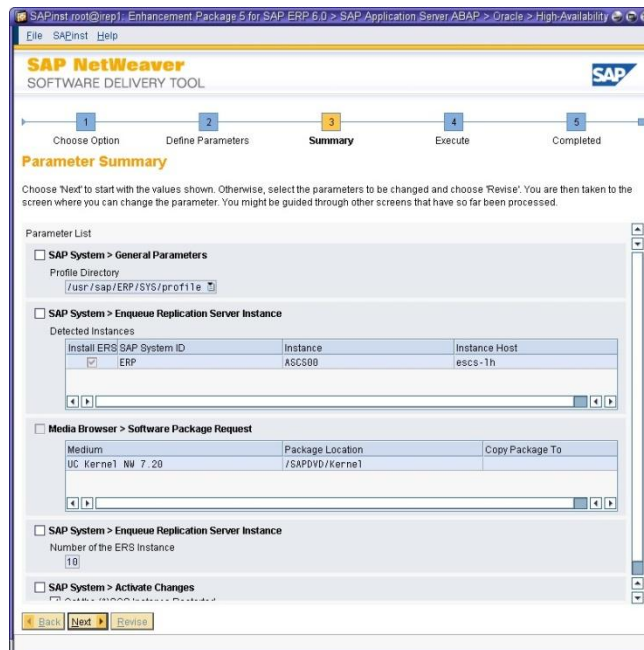

This summary lists the parameters provided. A parameter can be selected and modified if needed. Click “Next” to start the installation.

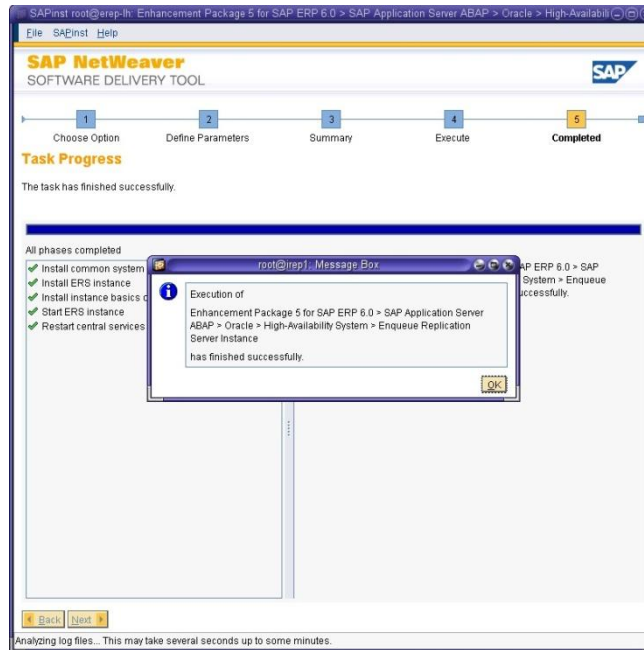

After a successful installation a confirmation message box is displayed. Click “OK”.

11f) Installation of the Central Instance

The next step is the installation of the Central Instance.

Log on as user root in the host epas-lh and make sure it is not DEPRECATED. Set the environment variable DISPLAY and start the SAP installer in the directory for the Solaris SPARC OS on the Installation Master DVD. The logical hostname needs to be specified as a suffix:

```
# sapinst SAPINST_USE_HOSTNAME=epas-lh
```

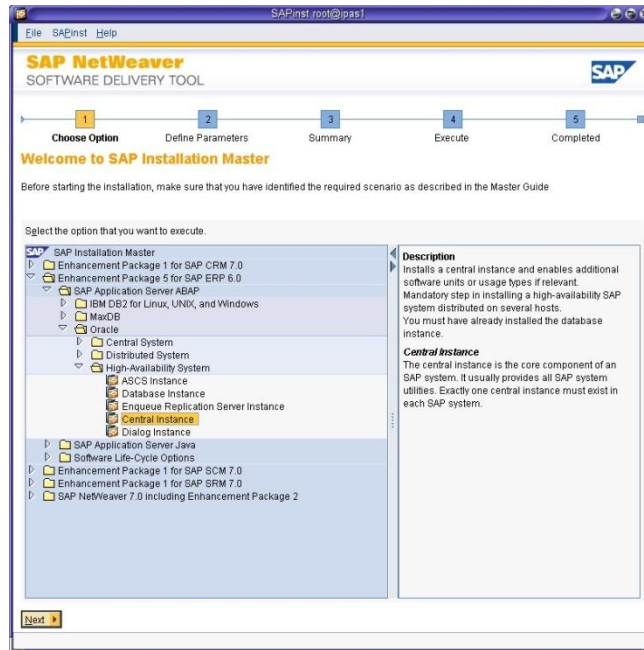

Select the following option: Enhancement Package 5 for SAP ERP 6.0 → SAP Application Server ABAP → Oracle → High-Availability System → Central Instance.

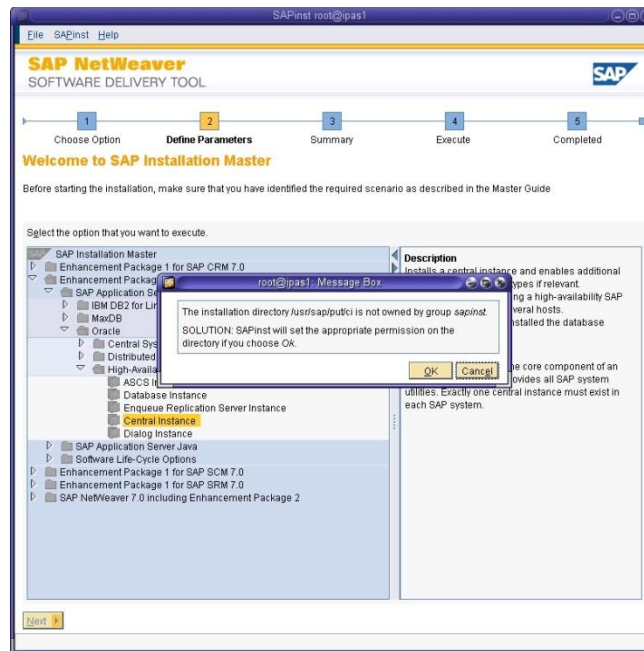

SAPINST sets the appropriate ownership permissions for the work directory. Accept the changes.

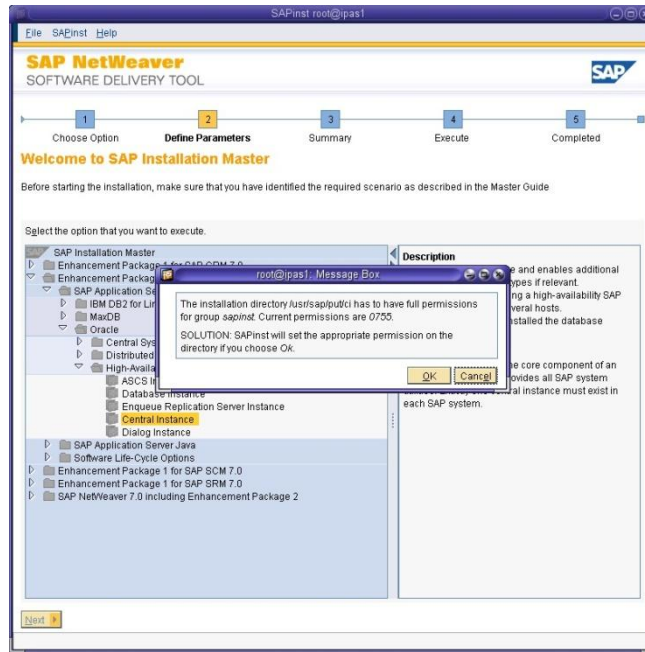

SAPINST sets the appropriate access permissions for the work directory. Accept the changes.

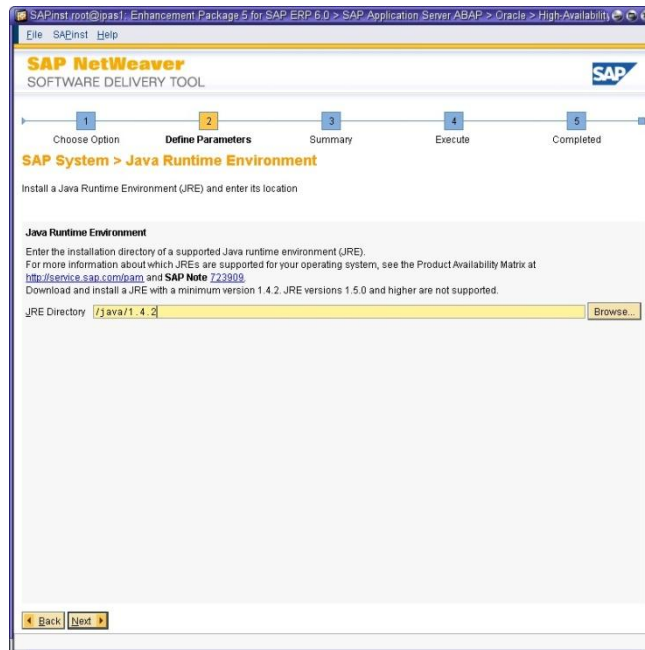

Choose the directory of the installed Java 1.4.2 instance.

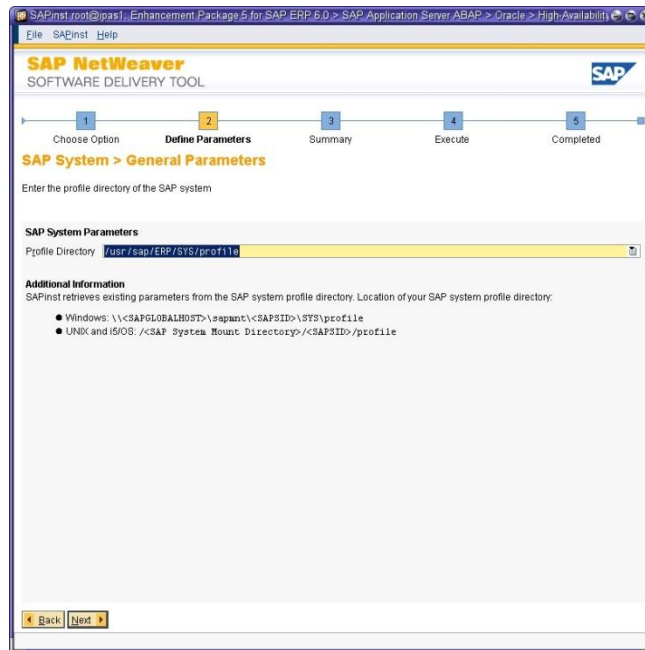

Keep the default profile directory.

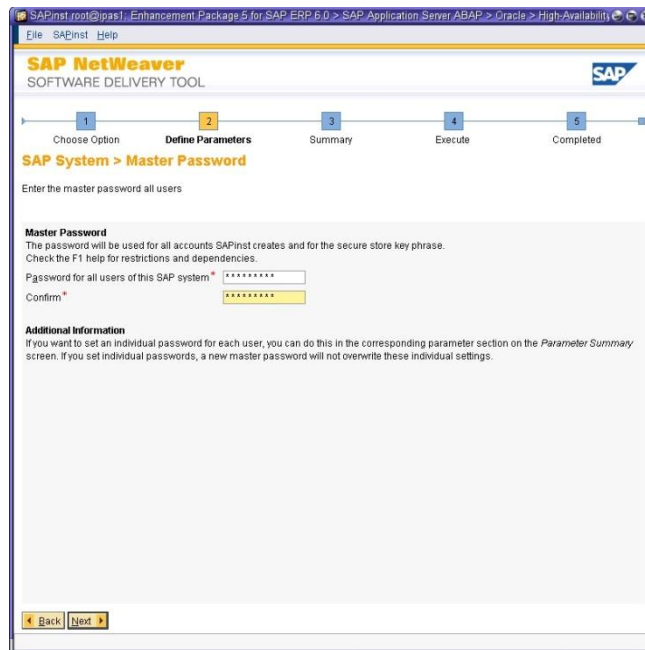

Enter the master password for all relevant accounts on operating system and application level.

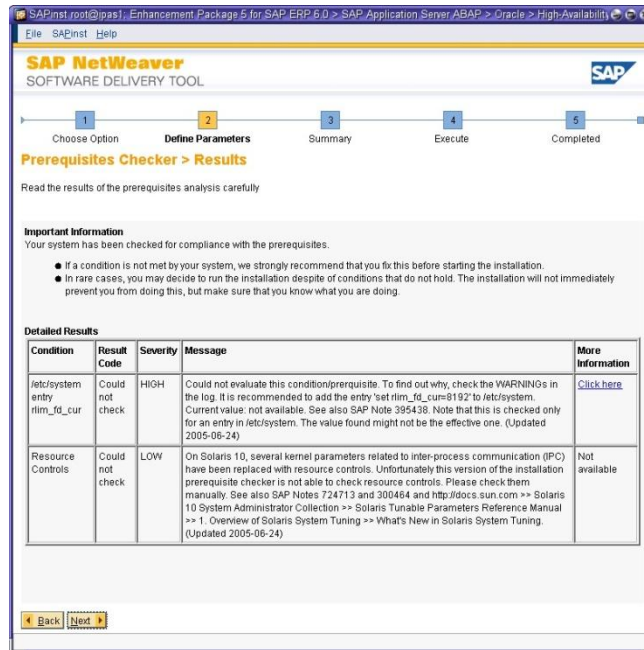

Review the results of the prerequisite checker.

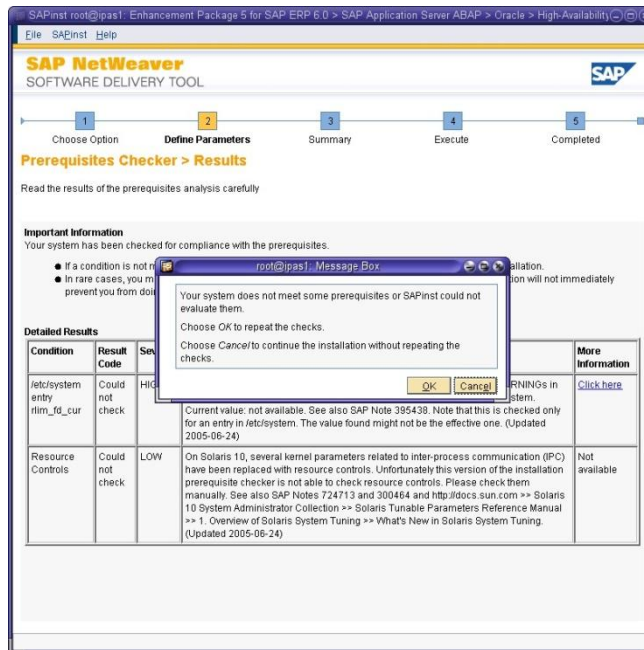

Click “Cancel” to continue the installation without repeating the checks.

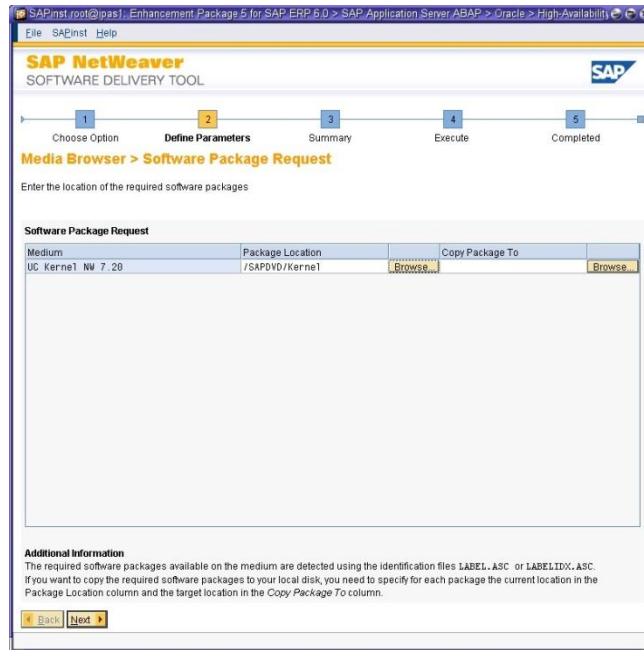

Indicate the location of the kernel DVD.

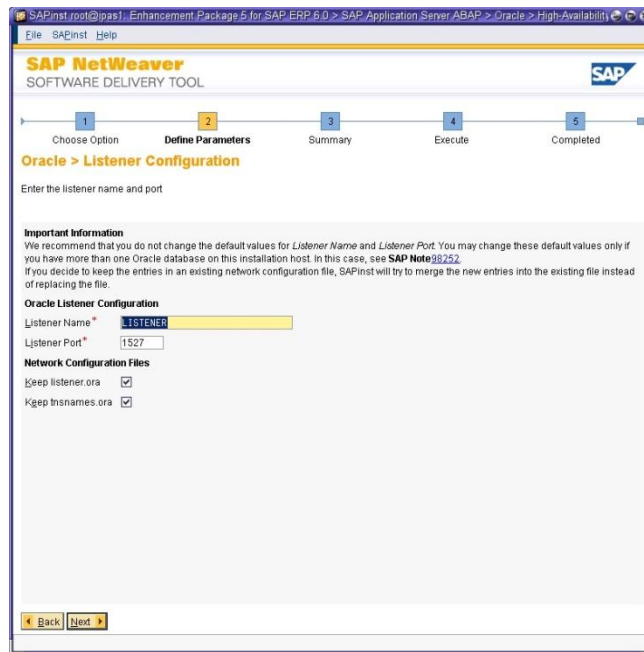

Make sure that the ports selected for the Oracle listener are not already used by other applications.

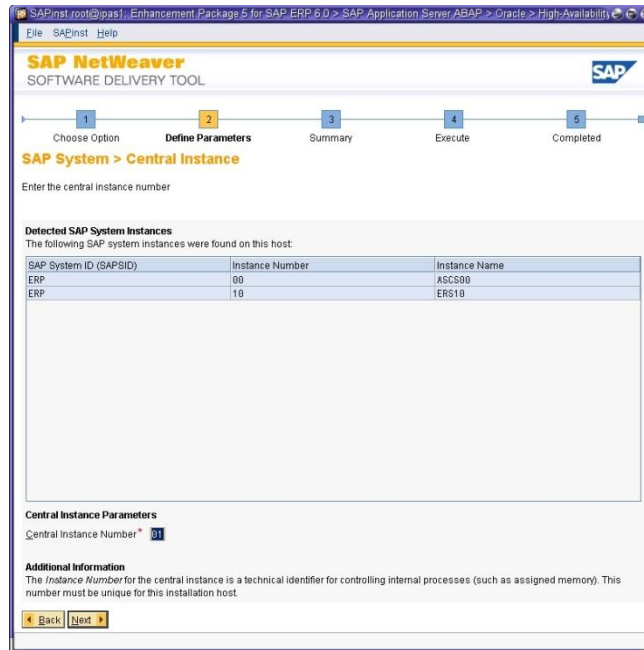

Leave the default parameter for the central instance.

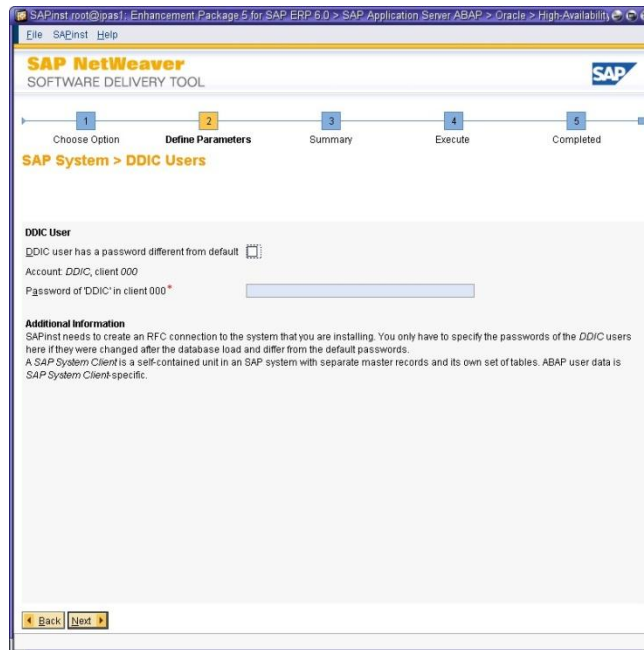

Indicate whether the DDIC user has a password different from default.

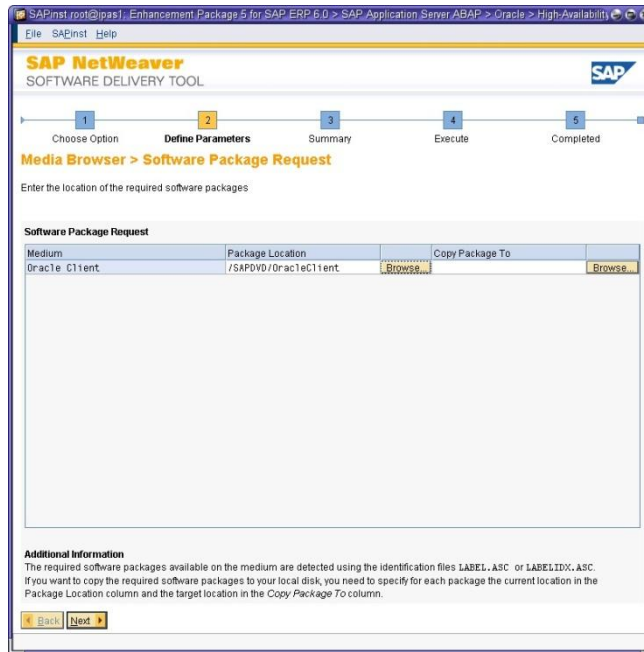

Indicate the location of the Oracle client DVD.

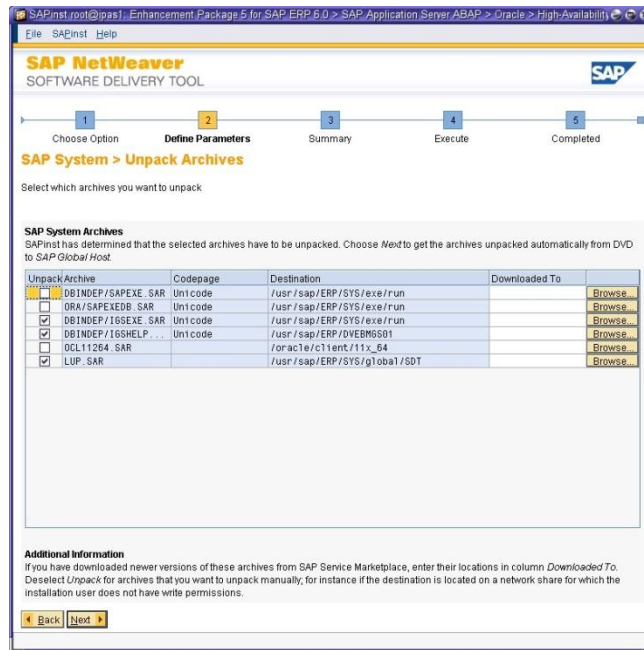

Leave the defaults to unpack the archives.

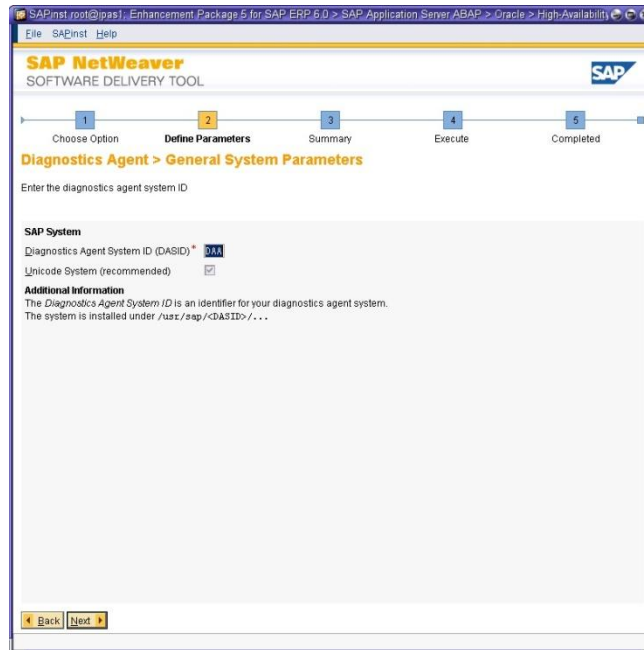

Choose the ID for the Diagnostics Agent. The default “DAA” can be accepted.

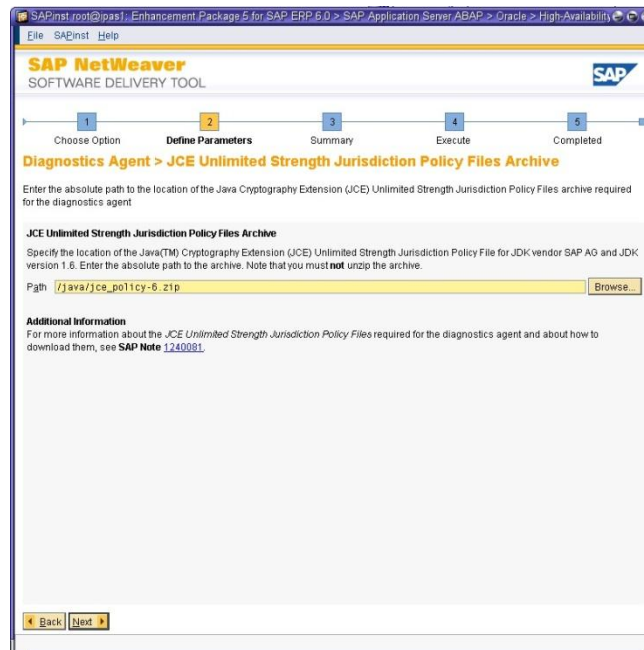

Indicate the location of the jce policy file.

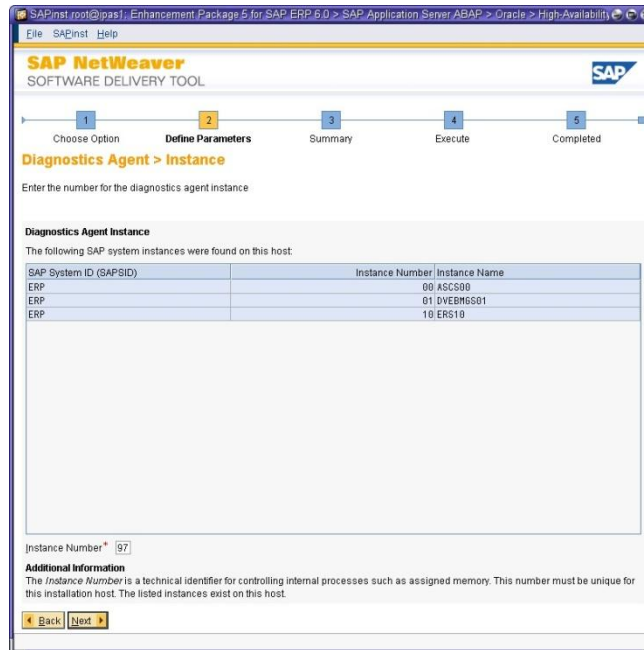

Leave the default for the instance number of the Diagnostics Agent.

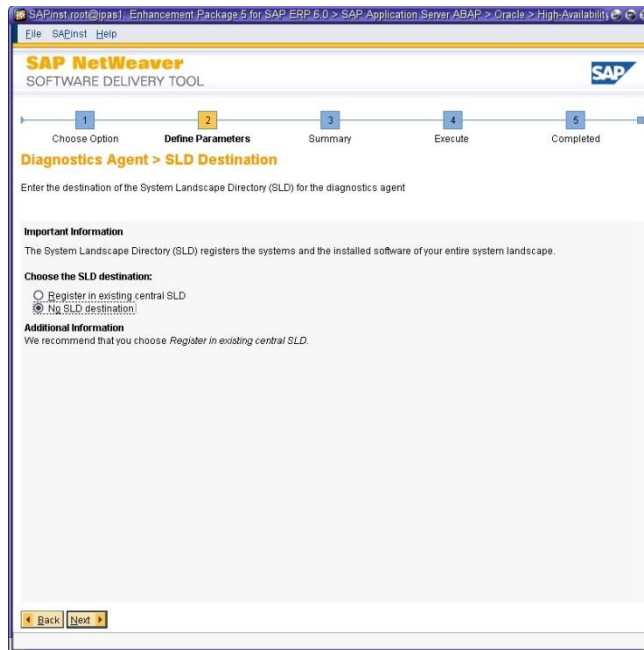

In our example we do not integrate our system in an existing central SLD.

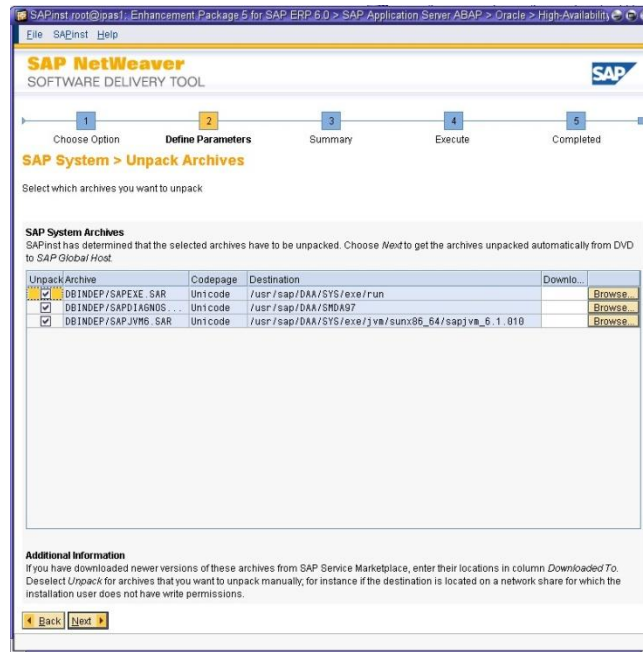

Leave the defaults to unpack the archives.

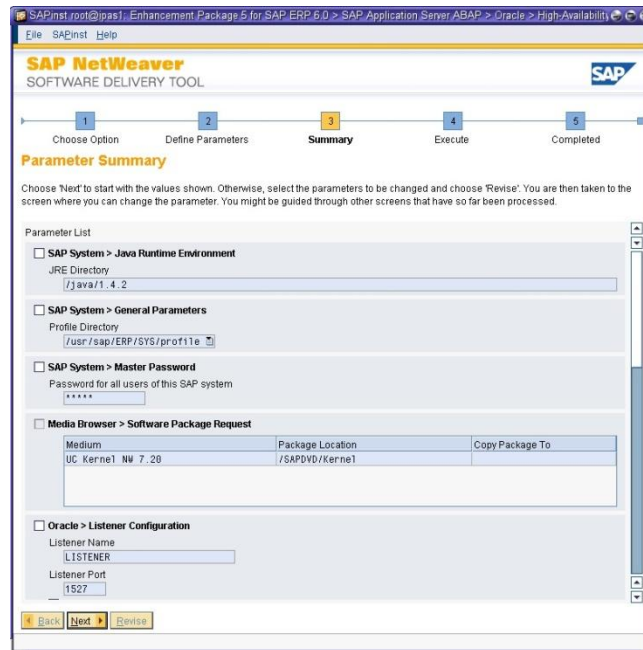

This summary lists the parameters provided. A parameter can be selected and modified if needed. Click “Next” to start the installation.

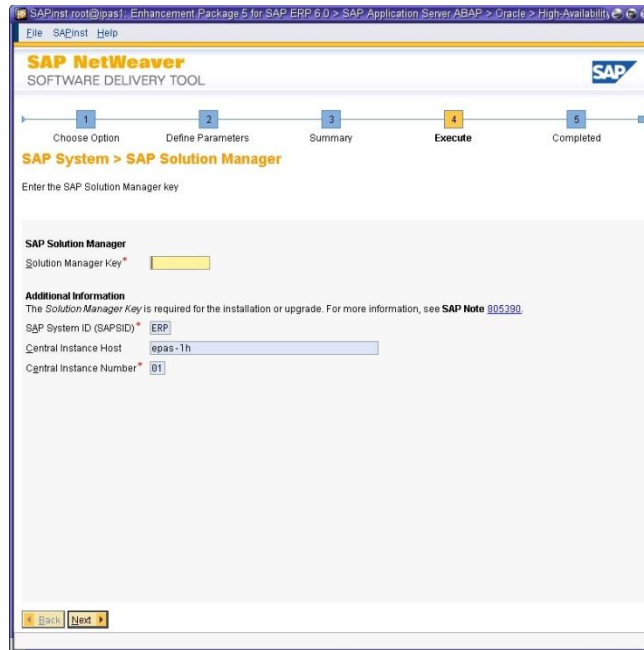

Enter the SAP Solution Manager key for your SAP system.

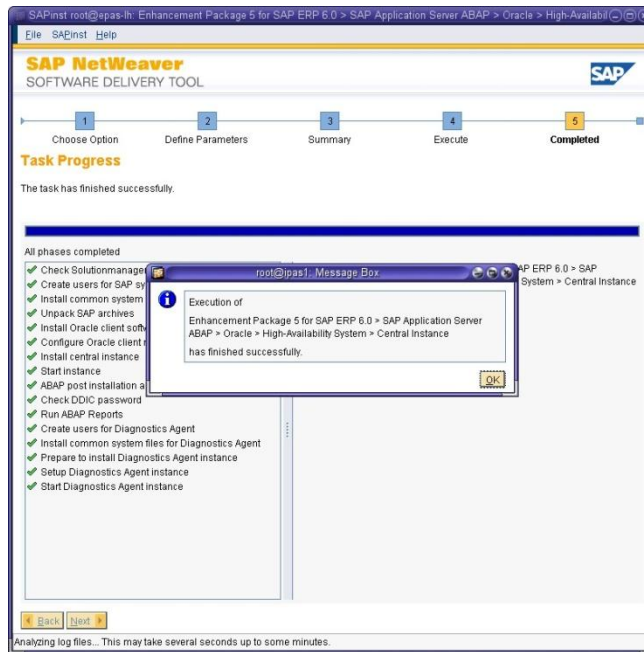

After a successful installation a confirmation message box is displayed. Click “OK”.

11g) Installation of the dialog instances

The next step is the installation of the dialog instance(s).

Log on as user root in one of the logical host for the dialog instance, for example eapp1-lh. Make sure that it is not DEPRECATED. Set the environment variable DISPLAY.

Start the SAP Installer SAPINST in the directory for the Solaris SPARC OS on the Installation Master DVD. The logical hostname needs to be specified as a suffix:

```
# sapinst SAPINST_USE_HOSTNAME=eapp1-lh
```

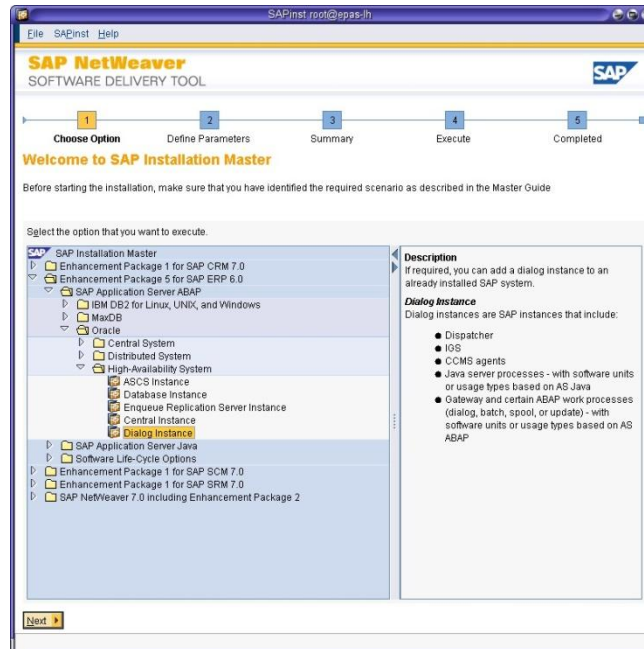

Select the following option: Enhancement Package 5 for SAP ERP 6.0 → SAP Application Server ABAP → Oracle → High-Availability System → Dialog Instance.

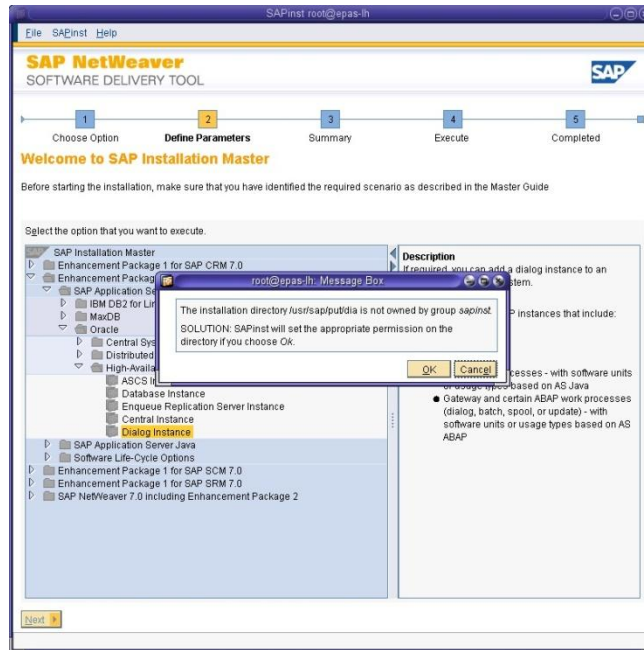

SAPINST sets the appropriate ownership permissions for the work directory. Accept the changes.

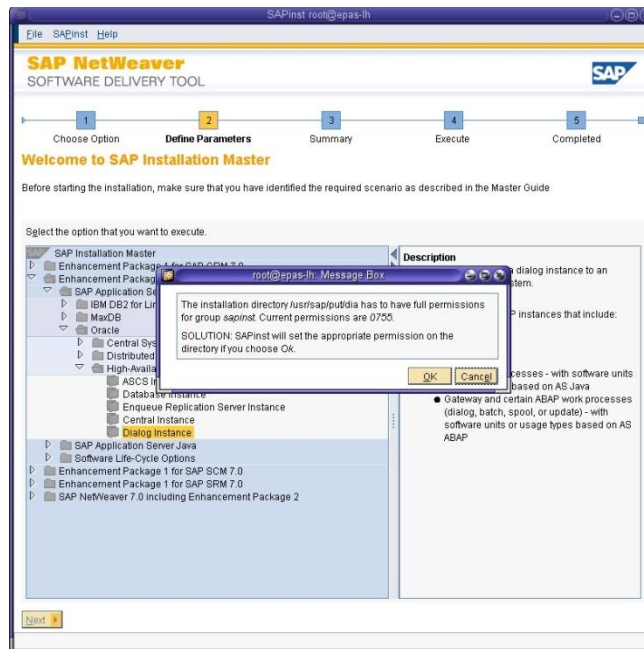

SAPINST sets the appropriate access permissions for the work directory. Accept the changes.

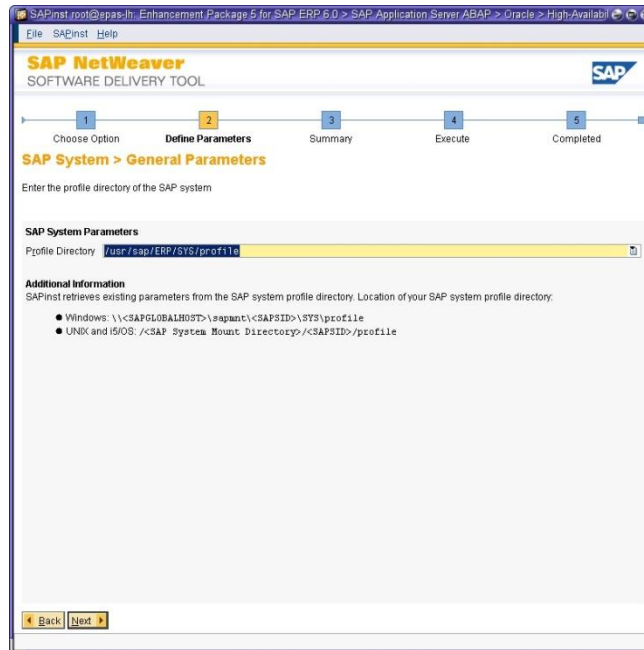

Leave the default location for the profile directory.

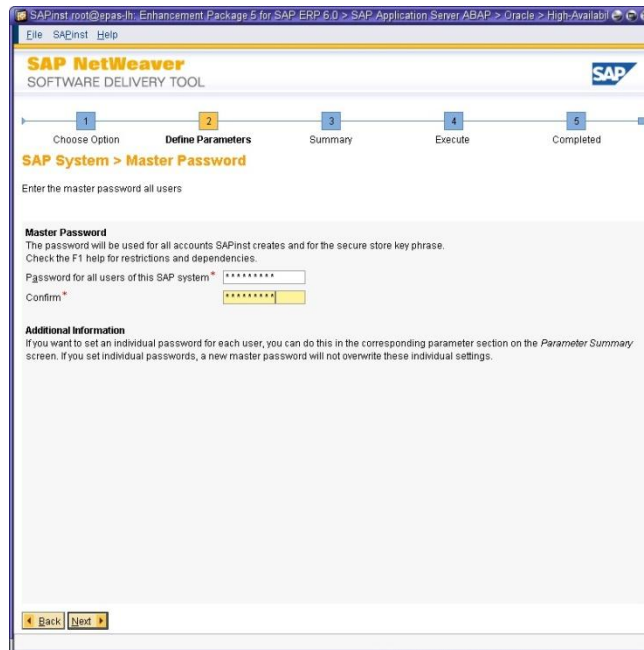

Enter the master password for all users.

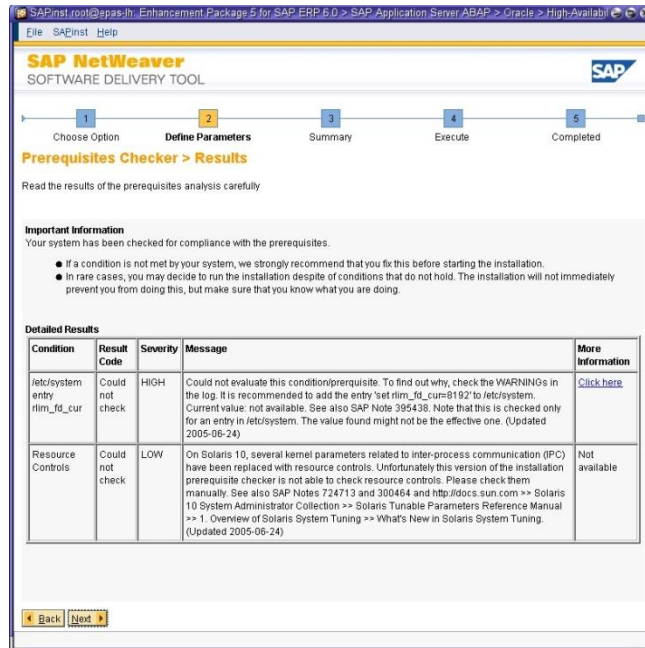

The prerequisite checker shows at least these two conditions, which can be ignored. The parameter `rlim_fd_cur` was already set as a project parameter but the prerequisite checker expects it explicitly in the file `/etc/system`. Click “Next”.

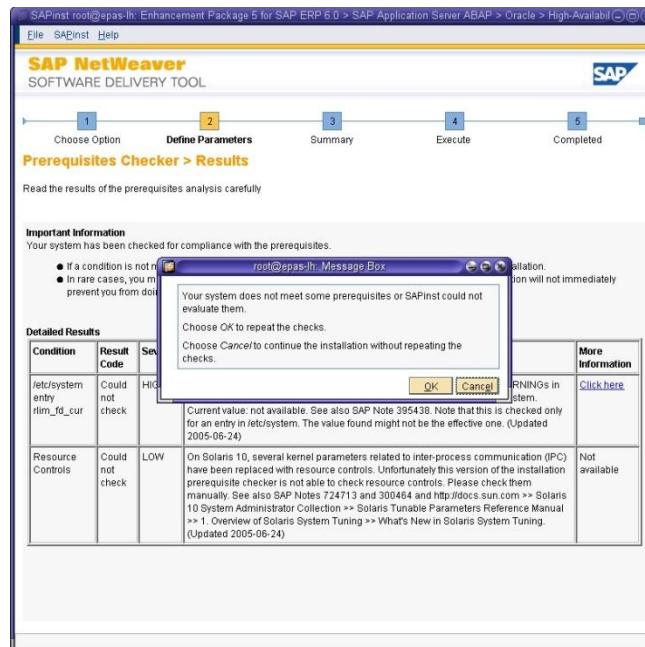

Click “Cancel” to continue the installation without repeating the checks.

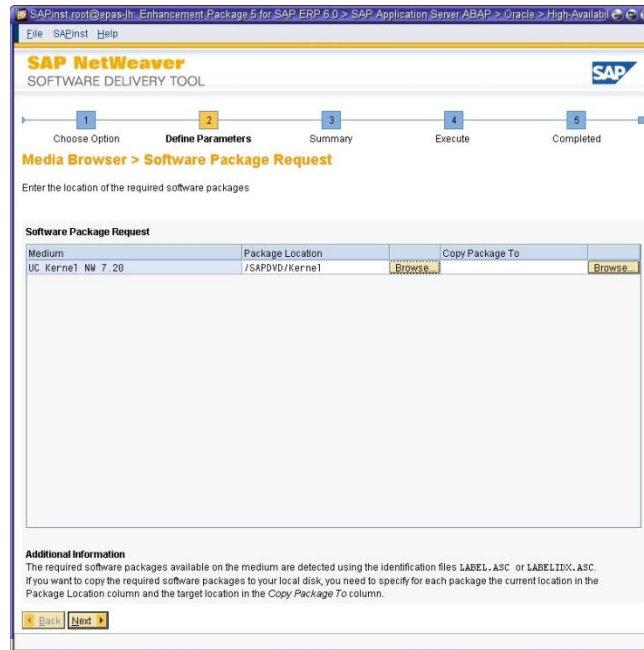

Indicate the location of the kernel DVD.

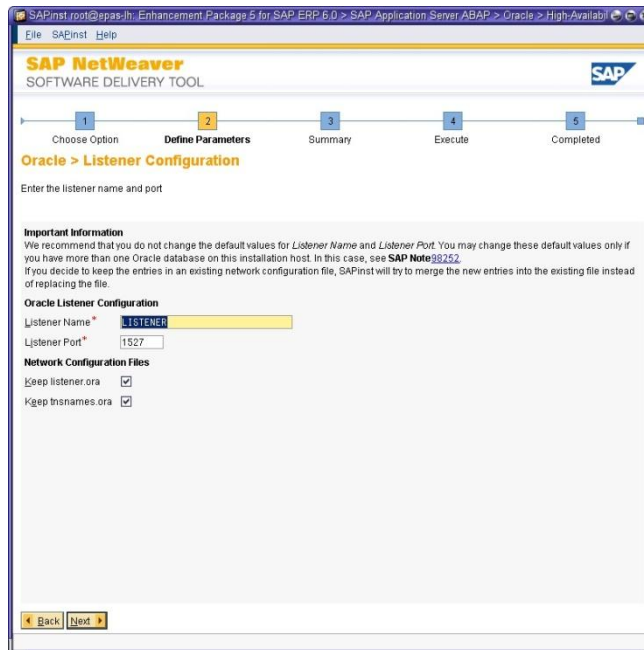

Make sure that the ports selected for the Oracle listener are not already used by other applications.

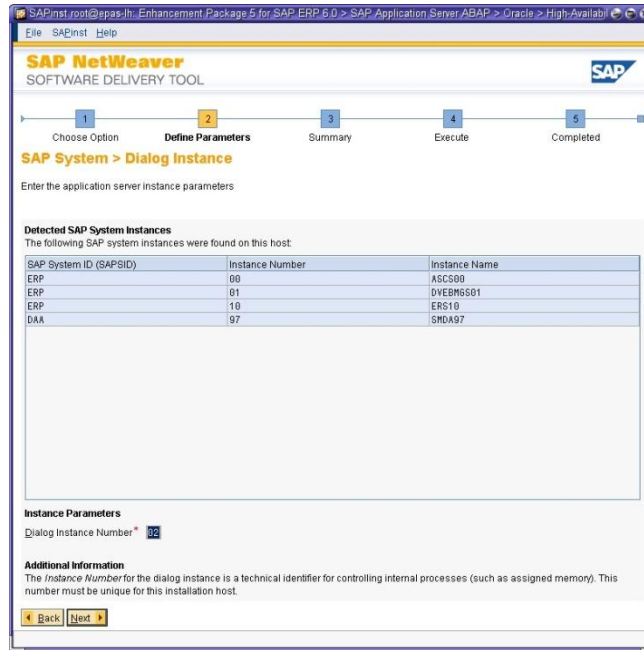

The dialog instance will be deployed by default as Instance Number “02”.

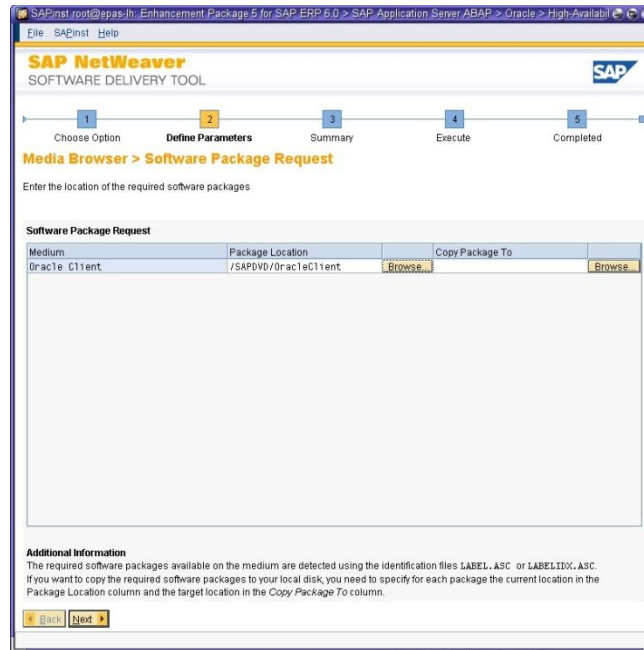

Indicate the location of the Oracle client DVD.

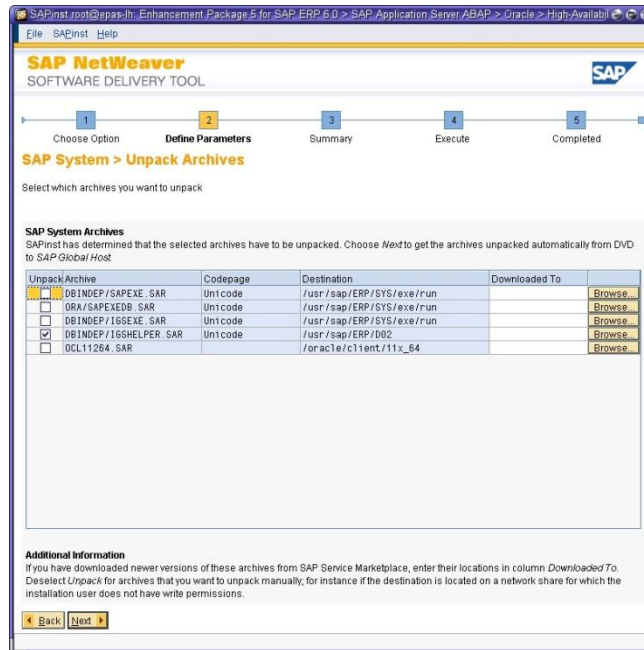

Leave the defaults to unpack the archives.

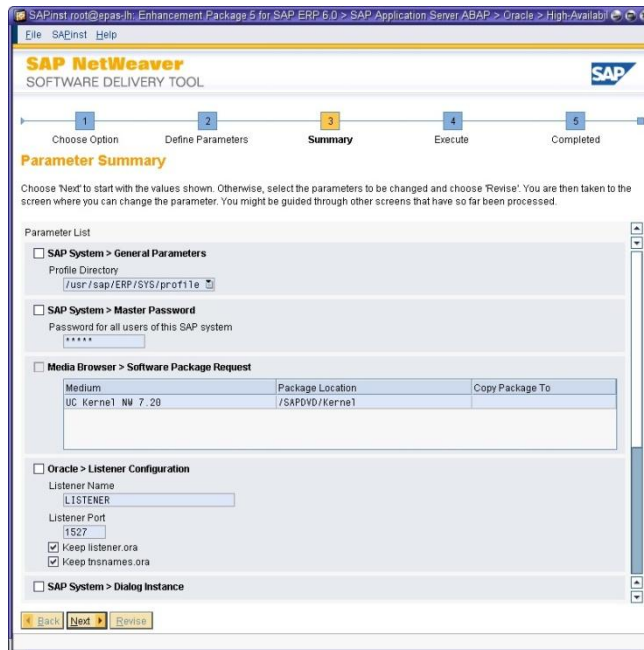

Finally the installer shows the parameter summary screen. Click “Next” to start the installation.

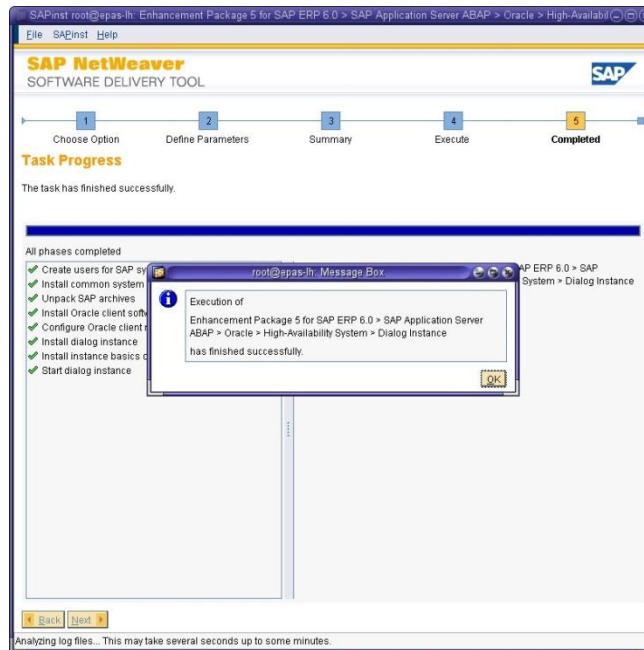

After a successful installation a confirmation message box is displayed. Click “OK”.

If necessary, repeat the last installation steps to install additional dialog instances.

After the SAP installation, ensure that all the files and environment are identical on the zones in the same zone cluster. The cluster console program (package SUNWccon or SUNWcluster) can be used to control multiple terminals simultaneously.

Step 12. Database Migration to Exadata Storage

During the previous sapinst installation, the Oracle Database was installed on to the ZFS Storage Appliance. To take advantage of the database acceleration from the Exadata Storage Servers, the database now needs to be moved over to the Exadata Storage Servers.

Note: A newer version of the sapinst installer will allow installing SAP with the Database directly on the Exadata Storage Servers, eliminating this extra step. This version was not available at the time this solution was developed.

12a) Migration of the Database from ZFS Storage Appliance to Exadata Storage Nodes

Definitions:

- original (source) database: SID QO1, service name QO1
- duplicated (target) database: SID QO1, service name QO1DUP

Set the environment

Logon to host etc4-cn01 as user oracle and set the environment.

Example for bash shell:

```
oracle@etc4-cn01:~$ export ORACLE_SID=+ASM1
oracle@etc4-cn01:~$ export ORACLE_HOME=/u01/app/11.2.0.2/grid
oracle@etc4-cn01:~$ export
PATH=.:/usr/kerberos/bin:/usr/local/bin:/bin:/usr/bin:/u01/app/oracle/product/11.2
.0.2/dbhome_1/bin
```

Password file creation

Configuration of a password file for the database instance.

```
oracle@etc4-cn01:~$ cd /u01/app/oracle/product/11.2.0.2/dbhome_1/dbs
oracle@etc4-cn01:~$ orapwd file=orapwQ01 entries=10 password=<password>
```

SQL*Net configuration on sapdb-lh

SQL*Net configuration in source system sapdb-lh

listener.ora: no additional entries are necessary

```
ipas1:/oracle/Q01/11203/network/admin# cat listener.ora
#####
# Filename.....: listener.ora
# Created.....: created by SAP AG, R/3 Rel. >= 6.10
# Name.....:
# Date.....:
# @(#) $Id: //bas/720_REL/src/krn/tpls/ora/LISTENER.ORA#1 $
#####
ADMIN_RESTRICTIONS_LISTENER = on
LISTENER =
  (ADDRESS_LIST =
    (ADDRESS =
      (PROTOCOL = IPC)
      (KEY = Q01.WORLD)
    )
    (ADDRESS=
      (PROTOCOL = IPC)
      (KEY = Q01)
    )
    (ADDRESS =
      (COMMUNITY = SAP.WORLD)
      (PROTOCOL = TCP)
      (HOST = esapdb-lh)
      (PORT = 1527)
    )
  )
STARTUP_WAIT_TIME_LISTENER = 0
CONNECT_TIMEOUT_LISTENER = 10
TRACE_LEVEL_LISTENER = OFF
SID_LIST_LISTENER =
  (SID_LIST =
    (SID_DESC =
      (SID_NAME = Q01)
      (ORACLE_HOME = /oracle/Q01/112_64)
```

tnsnames.ora: enter the information for the target database (service name Q01DUP)

```
ipas1:/oracle/Q01/11203/network/admin# cat tnsnames.ora
#####
```

```

# Filename.....: tnsnames.ora
# Created.....: created by SAP AG, R/3 Rel. >= 6.10
# Name.....:
# Date.....:
# @(#) $Id: //bas/720_REL/src/krn/tpls/ora/TNSNAMES.ORA#1 $
#####
QO1.WORLD=
  (DESCRIPTION =
    (ADDRESS_LIST =
      (ADDRESS =
        (COMMUNITY = SAP.WORLD)
        (PROTOCOL = TCP)
        (HOST = esapdb-lh)
        (PORT = 1527)
      )
    )
    (CONNECT_DATA =
      (SID = QO1)
      (GLOBAL_NAME = QO1.WORLD)
    )
  )
QO1DUP.WORLD =
  (DESCRIPTION =
    (ADDRESS_LIST =
      (ADDRESS =
        (COMMUNITY = SAP.WORLD)
        (PROTOCOL = TCP)
        (HOST = 10.129.184.15)
        (PORT = 1521))
    )
    (CONNECT_DATA =
      (SID = QO1)
      (GLOBAL_NAME = QO1.WORLD)
    )
  )
)

```

sqlnet.ora:

```

ipas1:/oracle/QO1/11203/network/admin# cat sqlnet.ora
#####
# Filename.....: sqlnet.ora
# Created.....: created by SAP AG, R/3 Rel. >= 6.10
# Name.....:
# Date.....:
# @(#) $Id: //bas/720_REL/src/krn/tpls/ora/SQLNET.ORA#1 $
#####
AUTOMATIC_IPC = ON
TRACE_LEVEL_CLIENT = OFF
NAMES.DIRECTORY_PATH = (TNSNAMES,EZCONNECT)
NAMES.DEFAULT_DOMAIN = WORLD
# 05.01.06 unsupported parameter now
#NAME.DEFAULT_ZONE = WORLD
# 05.01.06 set the default to 10
SQLNET.EXPIRE_TIME = 10
# 05.01.06 set to default
#TCP.NODELAY=YES
# 05.01.06 set to 32768
DEFAULT_SDU_SIZE=32768

```

SQL*Net configuration on etc4-cn01

SQL*Net configuration in target system etc4-cn01

listener.ora: enter SID QO1

```

oracle@etc4-cn01:~$ cd /u01/app/11.2.0.2/grid/network/admin
oracle@etc4-cn01:~$ cat listener.ora

LISTENER_IB=(DESCRIPTION=(ADDRESS_LIST=(ADDRESS=(PROTOCOL=IPC)(KEY=LISTENER_IB))))
# line added by Agent
LISTENER=(DESCRIPTION=(ADDRESS_LIST=(ADDRESS=(PROTOCOL=IPC)(KEY=LISTENER))))
# line added by Agent
LISTENER_SCAN3=(DESCRIPTION=(ADDRESS_LIST=(ADDRESS=(PROTOCOL=IPC)(KEY=LISTENER_SCAN3))))
# line added by Agent
LISTENER_SCAN2=(DESCRIPTION=(ADDRESS_LIST=(ADDRESS=(PROTOCOL=IPC)(KEY=LISTENER_SCAN2))))
# line added by Agent
LISTENER_SCAN1=(DESCRIPTION=(ADDRESS_LIST=(ADDRESS=(PROTOCOL=IPC)(KEY=LISTENER_SCAN1))))
# line added by Agent
ENABLE_GLOBAL_DYNAMIC_ENDPOINT_LISTENER_SCAN1=ON
# line added by Agent
ENABLE_GLOBAL_DYNAMIC_ENDPOINT_LISTENER_SCAN2=ON
# line added by Agent
ENABLE_GLOBAL_DYNAMIC_ENDPOINT_LISTENER_SCAN3=ON
# line added by Agent
ENABLE_GLOBAL_DYNAMIC_ENDPOINT_LISTENER=ON
# line added by Agent
ENABLE_GLOBAL_DYNAMIC_ENDPOINT_LISTENER_IB=ON
# line added by Agent
ADMIN_RESTRICTION_LISTENER=ON
#
#
#
SID_LIST_LISTENER =
  (SID_LIST =
    (SID_DESC =
      (SID_NAME = QO1)
      (ORACLE_HOME = /u01/app/oracle/product/11.2.0.2/dbhome_1 )
    )
  )
)

```

tnsnames.ora: enter SID QO1

```

oracle@etc4-cn01:~$ cd /u01/app/oracle/product/11.2.0.2/dbhome_1/network/admin
oracle@etc4-cn01:~$ cat tnsnames.ora

# tnsnames.ora Network Configuration File:
/u01/app/oracle/product/11.2.0.2/dbhome_1/network/admin/tnsnames.ora
# Generated by Oracle configuration tools.

+ASM1 =
  (DESCRIPTION =
    (ADDRESS_LIST =
      (ADDRESS = (COMMUNITY = SAP.WORLD) (PROTOCOL = TCP) (HOST =
10.129.184.15) (PORT = 1521))
    )
    (CONNECT_DATA =
      (SID = +ASM1)
      (GLOBAL_NAME = +ASM1)
    )
  )
)

QO1 =
  (DESCRIPTION =
    (ADDRESS_LIST =
      (ADDRESS = (COMMUNITY = SAP.WORLD) (PROTOCOL = TCP) (HOST = esapdb-lh) (PORT =
1521))
    )
    (CONNECT_DATA =
      (SID = QO1)
      (GLOBAL_NAME = QO1)
    )
  )
)

QO1DUP =

```



```

      (DESCRIPTION =
        (ADDRESS_LIST =
          (ADDRESS = (COMMUNITY = SAP.WORLD) (PROTOCOL = TCP) (HOST =
10.129.184.15) (PORT = 1521))
        )
        (CONNECT_DATA =
          (SID = Q01)
          (GLOBAL_NAME = Q01)
        )
      )
DBM =
  (DESCRIPTION =
    (ADDRESS = (PROTOCOL = TCP) (HOST = etc4-scan) (PORT = 1521))
    (CONNECT_DATA =
      (SERVER = DEDICATED)
      (SERVICE_NAME = dbm)
    )
  )
)

ipas1:/oracle/Q01/11203/network/admin# cat sqlnet.ora
#####
# Filename.....: sqlnet.ora
# Created.....: created by SAP AG, R/3 Rel. >= 6.10
# Name.....:
# Date.....:
# @(#) $Id: //bas/720_REL/src/krn/tpls/ora/SQLNET.ORA#1 $
#####
AUTOMATIC_IPC = ON
TRACE_LEVEL_CLIENT = OFF
NAMES_DIRECTORY_PATH = (TNSNAMES,EZCONNECT)
NAMES_DEFAULT_DOMAIN = WORLD
# 05.01.06 unsupported parameter now
#NAME.DEFAULT_ZONE = WORLD
# 05.01.06 set the default to 10
SQLNET.EXPIRE_TIME = 10
# 05.01.06 set to default
#TCP.NODELAY=YES
# 05.01.06 set to 32768
DEFAULT_SDU_SIZE=32768

```

sqlnet.ora:

```

oracle@etc4-cn01:$ cd /u01/app/11.2.0.2/grid/network/admin
oracle@etc4-cn01:$ cat sqlnet.ora

# sqlnet.ora.etc4-cn01 Network Configuration File:
/u01/app/11.2.0.2/grid/network/admin/sqlnet.ora.etc4-cn01
# Generated by Oracle configuration tools.

NAMES_DIRECTORY_PATH=(TNSNAMES, EZCONNECT)
ADR_BASE = /u01/app/oracle
SQLNET.EXPIRE_TIME=10
NAMES_DEFAULT_DOMAIN = WORLD
AUTOMATIC_IPC = ON

```

Target system setup

Add the groups oper, asmoper, asmadmin, asmdba and add user oracle to these groups on all db nodes:

```

root@etc4-cn01:# groupadd -g 703 oper
root@etc4-cn01:# groupadd -g 705 asmoper
root@etc4-cn01:# groupadd -g 706 asmadmin
root@etc4-cn01:# groupadd -g 707 asmdba
root@etc4-cn01:# usermod -G +oper,asmoper,asmadmin,asmdba oracle

```

Create a shell script user “oracle” can source for each Oracle Home that has been installed.

Environment for the ASM instance and to run GRID commands:

```
export ORACLE_SID=+ASM1
export ORACLE_HOME=/u01/app/11.2.0.2/grid
export
PATH=./usr/kerberos/bin:/usr/local/bin:/bin:/usr/bin:/u01/app/11.2.0.2/grid/bin
```

Environment for the new database instance:

```
export ORACLE_SID=Q01
export ORACLE_HOME=/u01/app/oracle/product/11.2.0.2/dbhome_1
export
PATH=./usr/kerberos/bin:/usr/local/bin:/bin:/usr/bin:/u01/app/oracle/product/11.2.0.2/dbhome_1/bin
```

Create a file initQ01.ora on the target system

List the logfiles on the source system: logon to host esapdb-lh as user oraq01

```
ierppas1:oraq01 2% sqlplus / as sysdba

SQL> select member from v$logfile;

MEMBER
-----
/oracle/Q01/origlogA/log_g11m3.dbf
/oracle/Q01/mirrlogA/log_g11m4.dbf
/oracle/Q01/origlogB/log_g12m3.dbf
/oracle/Q01/mirrlogB/log_g12m4.dbf
/oracle/Q01/origlogA/log_g13m3.dbf
/oracle/Q01/mirrlogA/log_g13m4.dbf
/oracle/Q01/origlogB/log_g14m3.dbf
/oracle/Q01/mirrlogB/log_g14m4.dbf
```

Full path of existing logfiles need to be added to pfile initQ01.ora

```
oracle@etc4-cn01:~$ cd /u01/app/oracle/product/11.2.0.2/dbhome_1/dbs
oracle@etc4-cn01:~$ cat initQ01.ora

*.db_name='Q01'
*.db_block_size=8192
*.compatible=11.2.0.2
*.audit_trail=none
*.log_archive_dest_1='location=+RECO_ETC4/Q01 valid_for=(ALL_LOGFILES,ALL_ROLES)
db_unique_name=Q01'
db_unique_name='Q01'
*.db_create_file_dest='+DATA_ETC4'
*.db_create_online_log_dest_1='+DATA_ETC4'
*.db_create_online_log_dest_2='+RECO_ETC4'
*.log_file_name_convert=
    '/oracle/Q01/origlogA/log_g11m3.dbf','+DATA_ETC4',
    '/oracle/Q01/mirrlogA/log_g11m4.dbf','+RECO_ETC4',
    '/oracle/Q01/origlogB/log_g12m3.dbf','+DATA_ETC4',
    '/oracle/Q01/mirrlogB/log_g12m4.dbf','+RECO_ETC4',
    '/oracle/Q01/origlogA/log_g13m3.dbf','+DATA_ETC4',
    '/oracle/Q01/mirrlogA/log_g13m4.dbf','+RECO_ETC4',
    '/oracle/Q01/origlogB/log_g14m3.dbf','+DATA_ETC4',
    '/oracle/Q01/mirrlogB/log_g14m4.dbf','+RECO_ETC4'
*.control_files='+DATA_ETC4/Q01/CONTROLFILE/cntrl1.dbf','+RECO_ETC4/Q01/CONTROLFIL
E/cntrl2.dbf'
*.db_recovery_file_dest='+RECO_ETC4'
*.db_recovery_file_dest_size=4G
```

```
*.shared_pool_size=2181038080
```

Start the target instance into nomount state

Logon to the host esapdb-lh as user oraql and connect to the target database:

```
isapdb1:oraql 25% sqlplus sys/<password>@qoldup as sysdba
SQL*Plus: Release 11.2.0.3.0 Production on Thu Jul 12 13:41:47 2012
Copyright (c) 1982, 2011, Oracle. All rights reserved.
```

Connected to an idle instance.

```
SQL> startup nomount
ORACLE instance started.

Total System Global Area 2941173760 bytes
Fixed Size 2162544 bytes
Variable Size 2248147088 bytes
Database Buffers 536870912 bytes
Redo Buffers 153993216 bytes
```

Database Duplication using RMAN

Use Oracle Recovery Manager (RMAN) to duplicate the database from the active database. The source database must be in "mount" or "open" state.

Logon to the host esapdb-lh as user oraql:

```
isapdb1:oraql 42% rman nocatalog
Recovery Manager: Release 11.2.0.3.0 - Production on Thu Jul 12 14:18:52 2012
Copyright (c) 1982, 2011, Oracle and/or its affiliates. All rights reserved.

RMAN> connect target sys/<password>@Q01
connected to target database: Q01 (DBID=26085901)
using target database control file instead of recovery catalog

RMAN> connect auxiliary sys/<password>@Q01DUP
connected to auxiliary database: Q01 (not mounted)

RMAN> run {
2> ALLOCATE CHANNEL t1 DEVICE TYPE disk;
3> ALLOCATE CHANNEL t2 DEVICE TYPE disk;
4> ALLOCATE CHANNEL t3 DEVICE TYPE disk;
5> ALLOCATE CHANNEL t4 DEVICE TYPE disk;
6> ALLOCATE CHANNEL t5 DEVICE TYPE disk;
7> ALLOCATE CHANNEL t6 DEVICE TYPE disk;
8> ALLOCATE CHANNEL t7 DEVICE TYPE disk;
9> ALLOCATE CHANNEL t8 DEVICE TYPE disk;
10> ALLOCATE AUXILIARY CHANNEL a1 DEVICE TYPE disk;
11> duplicate target database
12> to Q01
13> from active database
14> nofilenamecheck;
15> }
using target database control file instead of recovery catalog
allocated channel: t1
channel t1: SID=8 device type=DISK
allocated channel: t2
```

```

channel t2: SID=579 device type=DISK
.....
.....
datafile 34 switched to datafile copy
input datafile copy RECID=33 STAMP=792746259 file
name=+DATA_ETC4/q01/datafile/psapsr3usr.600.792746055

contents of Memory Script:
{
  Alter clone database open resetlogs;
}
executing Memory Script

database opened
Finished Duplicate Db at 12-JUL-12
released channel: t1
released channel: t2
released channel: t3
released channel: t4
released channel: t5
released channel: t6
released channel: t7
released channel: t8
released channel: a1

```

Post duplication tasks

Ensure that all files are consistent and no blocks are corrupted:

```

RMAN> validate database;

Starting validate at 10-JUL-12
allocated channel: ORA_DISK_1
channel ORA_DISK_1: SID=246 device type=DISK
channel ORA_DISK_1: starting validation of datafile
channel ORA_DISK_1: specifying datafile(s) for validation
...
...

channel ORA_DISK_1: starting validation of datafile
channel ORA_DISK_1: specifying datafile(s) for validation
including current control file for validation
including current SPFILE in backup set
channel ORA_DISK_1: validation complete, elapsed time: 00:00:02
List of Control File and SPFILE
=====
File Type      Status Blocks Failing Blocks Examined
-----
SPFILE         OK        0           2
Control File OK        0          1672
Finished validate at 10-JUL-12

```

Check that the files were copied to the correct ASM disk group:

```

oracle@etc4-cn01:~$ sqlplus / as sysdba

SQL*Plus: Release 11.2.0.3.0 Production on Mon Sep 3 07:13:42 2012

Copyright (c) 1982, 2011, Oracle. All rights reserved.

Connected to:
Oracle Database 11g Enterprise Edition Release 11.2.0.3.0 - 64bit Production
With the Partitioning, Real Application Clusters, Automatic Storage Management,
OLAP,
Data Mining and Real Application Testing options

```

```
SQL> select name from v$datafile;

NAME
-----
+DATA_ETC4/q01/datafile/system.285.775883053
+DATA_ETC4/q01/datafile/sysaux.283.775883075
+DATA_ETC4/q01/datafile/sysaux.addbypaul
+DATA_ETC4/q01/datafile/psapsr3.301.775882811
+DATA_ETC4/q01/datafile/psapsr3.300.775882825
+DATA_ETC4/q01/datafile/psapsr3.299.775882841
+DATA_ETC4/q01/datafile/psapsr3.298.775882855
+DATA_ETC4/q01/datafile/psapsr3.297.775882871
+DATA_ETC4/q01/datafile/psapsr3.296.775882887
+DATA_ETC4/q01/datafile/psapsr3.295.775882901
+DATA_ETC4/q01/datafile/psapsr3.294.775882917
```

```
NAME
-----
+DATA_ETC4/q01/datafile/psapsr3.293.775882931
+DATA_ETC4/q01/datafile/psapsr3.292.775882947
+DATA_ETC4/q01/datafile/psapsr3.291.775882963
+DATA_ETC4/q01/datafile/psapsr3.290.775882977
+DATA_ETC4/q01/datafile/psapsr3.289.775882993
+DATA_ETC4/q01/datafile/psapsr3.288.775883007
+DATA_ETC4/q01/datafile/psapsr3.287.775883023
+DATA_ETC4/q01/datafile/psapsr3.284.775883069
+DATA_ETC4/q01/datafile/psapsr3702.313.775882437
+DATA_ETC4/q01/datafile/psapsr3702.312.775882473
+DATA_ETC4/q01/datafile/psapsr3702.311.775882507
```

```
NAME
-----
+DATA_ETC4/q01/datafile/psapsr3702.310.775882543
+DATA_ETC4/q01/datafile/psapsr3702.308.775882603
+DATA_ETC4/q01/datafile/psapsr3702.307.775882639
+DATA_ETC4/q01/datafile/psapsr3702.306.775882663
+DATA_ETC4/q01/datafile/psapsr3702.314.775882403
+DATA_ETC4/q01/datafile/psapsr3702.315.775882367
+DATA_ETC4/q01/datafile/psapsr3702.309.775882579
+DATA_ETC4/q01/datafile/psapsr3702.305.775882699
+DATA_ETC4/q01/datafile/psapsr3702.304.775882725
+DATA_ETC4/q01/datafile/psapsr3702.303.775882759
+DATA_ETC4/q01/datafile/psapsr3702.302.775882785
```

```
NAME
-----
+DATA_ETC4/q01/datafile/psapsr3usr.282.775883083
+DATA_ETC4/q01/datafile/psapundo_002
+DATA_ETC4/q01/datafile/psapundo_001
+RECO_ETC4/q01/datafile/psapundo_003
+RECO_ETC4/q01/datafile/psapundo_004
+DATA_ETC4/q01/datafile/sysaux.addbypaul2
```

39 rows selected.

```
SQL> select name from v$controlfile;
```

```
NAME
-----
+DATA_ETC4/q01/controlfile/cntrl1.dbf
+RECO_ETC4/q01/controlfile/cntrl2.dbf
```

```
SQL> select member from v$logfile;
```

```
MEMBER
-----
+DATA_ETC4/q01/onlinelog/group_8.604.792746389
+RECO_ETC4/q01/onlinelog/group_8.437.792746409
```

```

+DATA_ETC4/q01/onlinelog/group_7.603.792746349
+RECO_ETC4/q01/onlinelog/group_7.436.792746369
+DATA_ETC4/q01/onlinelog/group_6.602.792746309
+RECO_ETC4/q01/onlinelog/group_6.435.792746327
+DATA_ETC4/q01/onlinelog/group_5.601.792746267
+RECO_ETC4/q01/onlinelog/group_5.434.792746287

8 rows selected.

```

12b) Enable Oracle RAC

Additional database configuration

Create undo tablespace: logon to db node 1 (etc4-cn01) as user oracle and set the environment for SID QO1.

```

oracle@etc4-cn01:~$ sqlplus / as sysdba

SQL*Plus: Release 11.2.0.3.0 Production on Fri Aug 31 05:29:24 2012

Copyright (c) 1982, 2011, Oracle. All rights reserved.

Connected to:
Oracle Database 11g Enterprise Edition Release 11.2.0.3.0 - 64bit Production
With the Partitioning, Real Application Clusters, Automatic Storage Management,
OLAP, Data Mining and Real Application Testing options

SQL> create undo tablespace psapundo_001 datafile
'+DATA_ETC4/q01/datafile/psapundo_001' size 10000m reuse;
SQL> create undo tablespace psapundo_002 datafile
'+DATA_ETC4/q01/datafile/psapundo_002' size 10000m reuse;
SQL> create undo tablespace psapundo_003 datafile
'+RECO_ETC4/q01/datafile/psapundo_003' size 10000m reuse;
SQL> create undo tablespace psapundo_004 datafile
'+RECO_ETC4/q01/datafile/psapundo_004' size 10000m reuse;

```

Logfile configuration for 4 RAC nodes:

```

SQL> alter database add logfile thread 1 group 11
('+DATA_ETC4/Q01/log1_g11_m1.dbf') size 4000m reuse;
SQL> alter database add logfile thread 1 group 12
('+DATA_ETC4/Q01/log1_g12_m1.dbf') size 4000m reuse;
SQL> alter database add logfile thread 1 group 13
('+RECO_ETC4/Q01/log1_g13_m1.dbf') size 4000m reuse;
SQL> alter database add logfile thread 1 group 14
('+RECO_ETC4/Q01/log1_g14_m1.dbf') size 4000m reuse;

SQL> alter database add logfile thread 2 group 21
('+DATA_ETC4/Q01/log1_g21_m1.dbf') size 4000m reuse;
SQL> alter database add logfile thread 2 group 22
('+DATA_ETC4/Q01/log1_g22_m1.dbf') size 4000m reuse;
SQL> alter database add logfile thread 2 group 23
('+RECO_ETC4/Q01/log1_g23_m1.dbf') size 4000m reuse;
SQL> alter database add logfile thread 2 group 24
('+RECO_ETC4/Q01/log1_g24_m1.dbf') size 4000m reuse;

SQL> alter database add logfile thread 3 group 31
('+DATA_ETC4/Q01/log1_g31_m1.dbf') size 4000m reuse;
SQL> alter database add logfile thread 3 group 32
('+DATA_ETC4/Q01/log1_g32_m1.dbf') size 4000m reuse;
SQL> alter database add logfile thread 3 group 33
('+RECO_ETC4/Q01/log1_g33_m1.dbf') size 4000m reuse;
SQL> alter database add logfile thread 3 group 34
('+RECO_ETC4/Q01/log1_g34_m1.dbf') size 4000m reuse;

```

```

SQL> alter database add logfile thread 4 group 41
('+DATA_ETC4/Q01/log1_g41_ml.dbf') size 4000m reuse;
SQL> alter database add logfile thread 4 group 42
('+DATA_ETC4/Q01/log1_g42_ml.dbf') size 4000m reuse;
SQL> alter database add logfile thread 4 group 43
('+RECO_ETC4/Q01/log1_g43_ml.dbf') size 4000m reuse;
SQL> alter database add logfile thread 4 group 44
('+RECO_ETC4/Q01/log1_g44_ml.dbf') size 4000m reuse;

SQL> alter database switch logfile;

SQL> alter database drop logfile group 1;
SQL> drop tablespace PSAPUNDO;

SQL> alter database enable public thread 1;
SQL> alter database enable public thread 2;
SQL> alter database enable public thread 3;
SQL> alter database enable public thread 4;

```

Update initQ01.ora

Edit pfile initQ01.ora, delete information from the migration steps and append additional parameters for the RAC nodes:

```

oracle@etc4-cn01:$ cd /u01/app/oracle/product/11.2.0.2/dbhome_1/dbs
oracle@etc4-cn01:$ cat initQ01.ora

*.db_name='Q01'
*.db_block_size=8192
*.compatible=11.2.0.2
*.audit_trail=none
*.log_archive_dest_1='location=+RECO_ETC4/Q01 valid_for=(ALL_LOGFILES,ALL_ROLES)
db_unique_name=Q01'
db_unique_name='Q01'
*.db_create_file_dest='+DATA_ETC4'
*.db_create_online_log_dest_1='+DATA_ETC4'
*.db_create_online_log_dest_2='+RECO_ETC4'
*.control_files='+DATA_ETC4/Q01/CONTROLFILE/cntrl1.dbf','+RECO_ETC4/Q01/CONTROLFILE/cntrl2.dbf'
*.db_recovery_file_dest='+RECO_ETC4'
*.db_recovery_file_dest_size=4G
*.shared_pool_size=2181038080

*.remote_login_passwordfile='exclusive'
*.remote_os_authent='TRUE'
*.undo_management = auto

Q011.instance_number = 1
Q011.thread = 1
Q011.instance_name = Q011
Q011.service_names = (Q01,Q011)
Q011.undo_tablespace='psapundo_001'

Q012.instance_number = 2
Q012.thread = 2
Q012.instance_name = Q012
Q012.service_names = (Q01,Q012)
Q012.undo_tablespace='psapundo_002'

Q013.instance_number = 3
Q013.thread = 3
Q013.instance_name = Q013
Q013.service_names = (Q01,Q013)
Q013.undo_tablespace='psapundo_003'

Q014.instance_number = 4
Q014.thread = 4
Q014.instance_name = Q014

```

```
Q014.service_names = (Q01,Q014)
Q014.undo_tablespace='psapundo 004'
```

Generate spfile

Create a binary spfile by using sqlplus

```
oracle@etc4-cn01:~$ sqlplus / as sysdba

SQL*Plus: Release 11.2.0.3.0 Production on Fri Aug 31 08:26:03 2012

Copyright (c) 1982, 2011, Oracle. All rights reserved.

Connected to:
Oracle Database 11g Enterprise Edition Release 11.2.0.3.0 - 64bit Production
With the Partitioning, Real Application Clusters, Automatic Storage Management,
OLAP,
Data Mining and Real Application Testing options

SQL> create spfile='+DATA_ETC4/Q01/SPFILEQ01.ora' from pfile='initQ01.ora';
```

Register to the grid

Register database Q01:

```
oracle@etc4-cn01:~$ srvctl add database -d Q01 -o $ORACLE_HOME -p
'+DATA_ETC4/Q01/SPFILEQ01.ora' -a "DATA_ETC4,RECO_ETC4"

Register RAC nodes:

oracle@etc4-cn01:~$ srvctl add instance -d Q01 -i Q011 -n etc4-cn01
oracle@etc4-cn01:~$ srvctl add instance -d Q01 -i Q012 -n etc4-cn02
oracle@etc4-cn01:~$ srvctl add instance -d Q01 -i Q013 -n etc4-cn03
oracle@etc4-cn01:~$ srvctl add instance -d Q01 -i Q014 -n etc4-cn04
```

Start the database:

```
oracle@etc4-cn01:~$ srvctl start database -d Q01
```

Step 13. Add RAC VIPs and Listeners on the IPoIB network

Verify that Clusterware has been configured with all the required networks

```
root@etc4-cn01:~# oifcfg getif
bondeth0 10.129.184.0 global public
bondib0 192.168.10.0 global cluster_interconnect
bondib1 192.168.10.0 global cluster_interconnect
ipmpapp0 192.168.30.0 global public
```

Add the IPoIB network

```
root@etc4-cn01:~# srvctl add network -k 2 -S 192.168.30.0/255.255.255.0/ipmpapp0
root@etc4-cn01:~# srvctl config network
Network exists: 1/10.129.184.0/255.255.255.0/bondeth0, type static
Network exists: 2/192.168.30.0/255.255.255.0/ipmpapp0, type static
root@etc4-cn01:~# olsnodes
etc4-cn01
etc4-cn02
etc4-cn03
etc4-cn04
```

Add RAC VIPs to this IPoIB network

```

root@etc4-cn01:~# srvctl add vip -n etc4-cn01 -A etc4-01-ib-vip/255.255.255.0 -k 2
root@etc4-cn01:~# srvctl add vip -n etc4-cn02 -A etc4-02-ib-vip/255.255.255.0 -k 2
root@etc4-cn01:~# srvctl add vip -n etc4-cn03 -A etc4-03-ib-vip/255.255.255.0 -k 2
root@etc4-cn01:~# srvctl add vip -n etc4-cn04 -A etc4-04-ib-vip/255.255.255.0 -k 2

```

As the oracle user add the listeners for the IPoIB network

```

oracle@etc4-cn01:~$ srvctl add listener -l LISTENER_IB -k 2 -p 1521 -s
oracle@etc4-cn01:~$ srvctl start listener -l LISTENER_IB

```

Add the following TNS definitions to the DB instances tnsnames.ora file

```

oracle@etc4-cn01:/u01/app/oracle/product/11.2.0.2/dbhome_1/network/admin$ tail -34
tnsnames.ora

LISTENER_IBREMOTE =
  (DESCRIPTION =
    (ADDRESS_LIST =
      (ADDRESS = (PROTOCOL = TCP) (HOST = etc4-02-ib-vip) (PORT = 1521))
      (ADDRESS = (PROTOCOL = TCP) (HOST = etc4-03-ib-vip) (PORT = 1521))
      (ADDRESS = (PROTOCOL = TCP) (HOST = etc4-04-ib-vip) (PORT = 1521))
    )
  )

LISTENER_IBLOCAL =
  (DESCRIPTION =
    (ADDRESS_LIST =
      (ADDRESS = (PROTOCOL = TCP) (HOST = etc4-01-ib-vip) (PORT = 1521))
    )
  )

LISTENER_10GBEREMOTE =
  (DESCRIPTION =
    (ADDRESS_LIST =
      (ADDRESS = (PROTOCOL = TCP) (HOST = etc4-02-vip) (PORT = 1521))
      (ADDRESS = (PROTOCOL = TCP) (HOST = etc4-03-vip) (PORT = 1521))
      (ADDRESS = (PROTOCOL = TCP) (HOST = etc4-04-vip) (PORT = 1521))
    )
  )

LISTENER_10GBELocal =
  (DESCRIPTION =
    (ADDRESS_LIST =
      (ADDRESS = (PROTOCOL = TCP) (HOST = etc4-01-vip) (PORT = 1521))
    )
  )

```

```

oracle@etc4-cn02:/u01/app/oracle/product/11.2.0.2/dbhome_1/network/admin$ tail -34
tnsnames.ora

LISTENER_IBREMOTE =
  (DESCRIPTION =
    (ADDRESS_LIST =
      (ADDRESS = (PROTOCOL = TCP) (HOST = etc4-01-ib-vip) (PORT = 1521))
      (ADDRESS = (PROTOCOL = TCP) (HOST = etc4-03-ib-vip) (PORT = 1521))
      (ADDRESS = (PROTOCOL = TCP) (HOST = etc4-04-ib-vip) (PORT = 1521))
    )
  )

```

```

LISTENER_IBLOCAL =
  (DESCRIPTION =
    (ADDRESS_LIST =
      (ADDRESS = (PROTOCOL = TCP) (HOST = etc4-02-ib-vip) (PORT = 1521))
    )
  )

LISTENER_10GBEREMOTE =
  (DESCRIPTION =
    (ADDRESS_LIST =
      (ADDRESS = (PROTOCOL = TCP) (HOST = etc4-01-vip) (PORT = 1521))
      (ADDRESS = (PROTOCOL = TCP) (HOST = etc4-03-vip) (PORT = 1521))
      (ADDRESS = (PROTOCOL = TCP) (HOST = etc4-04-vip) (PORT = 1521))
    )
  )

LISTENER_10GBELOCAL =
  (DESCRIPTION =
    (ADDRESS_LIST =
      (ADDRESS = (PROTOCOL = TCP) (HOST = etc4-02-vip) (PORT = 1521))
    )
  )

```

```

oracle@etc4-cn03:/u01/app/oracle/product/11.2.0.2/dbhome_1/network/admin$ tail -34
tnsnames.ora

```

```

LISTENER_IBREMOTE =
  (DESCRIPTION =
    (ADDRESS_LIST =
      (ADDRESS = (PROTOCOL = TCP) (HOST = etc4-02-ib-vip) (PORT = 1521))
      (ADDRESS = (PROTOCOL = TCP) (HOST = etc4-01-ib-vip) (PORT = 1521))
      (ADDRESS = (PROTOCOL = TCP) (HOST = etc4-04-ib-vip) (PORT = 1521))
    )
  )

LISTENER_IBLOCAL =
  (DESCRIPTION =
    (ADDRESS_LIST =
      (ADDRESS = (PROTOCOL = TCP) (HOST = etc4-03-ib-vip) (PORT = 1521))
    )
  )

LISTENER_10GBEREMOTE =
  (DESCRIPTION =
    (ADDRESS_LIST =
      (ADDRESS = (PROTOCOL = TCP) (HOST = etc4-02-vip) (PORT = 1521))
      (ADDRESS = (PROTOCOL = TCP) (HOST = etc4-01-vip) (PORT = 1521))
      (ADDRESS = (PROTOCOL = TCP) (HOST = etc4-04-vip) (PORT = 1521))
    )
  )

LISTENER_10GBELOCAL =
  (DESCRIPTION =
    (ADDRESS_LIST =
      (ADDRESS = (PROTOCOL = TCP) (HOST = etc4-03-vip) (PORT = 1521))
    )
  )

```

```

oracle@etc4-cn04:/u01/app/oracle/product/11.2.0.2/dbhome_1/network/admin$ tail -34
tnsnames.ora

```

```

LISTENER_IBREMOTE =
  (DESCRIPTION =
    (ADDRESS_LIST =
      (ADDRESS = (PROTOCOL = TCP) (HOST = etc4-02-ib-vip) (PORT = 1521))
      (ADDRESS = (PROTOCOL = TCP) (HOST = etc4-03-ib-vip) (PORT = 1521))
      (ADDRESS = (PROTOCOL = TCP) (HOST = etc4-01-ib-vip) (PORT = 1521))
    )
  )

```

```

)
LISTENER_IBLOCAL =
  (DESCRIPTION =
    (ADDRESS_LIST =
      (ADDRESS = (PROTOCOL = TCP) (HOST = etc4-04-ib-vip) (PORT = 1521))
    )
  )
)
LISTENER_10GBEREMOTE =
  (DESCRIPTION =
    (ADDRESS_LIST =
      (ADDRESS = (PROTOCOL = TCP) (HOST = etc4-02-vip) (PORT = 1521))
      (ADDRESS = (PROTOCOL = TCP) (HOST = etc4-03-vip) (PORT = 1521))
      (ADDRESS = (PROTOCOL = TCP) (HOST = etc4-01-vip) (PORT = 1521))
    )
  )
)
LISTENER_10GBELOCAL =
  (DESCRIPTION =
    (ADDRESS_LIST =
      (ADDRESS = (PROTOCOL = TCP) (HOST = etc4-04-vip) (PORT = 1521))
    )
  )
)

```

Log in to the DB and configure the instances to register with all listeners of all the networks

```

oracle@etc4-cn01:~$ sqlplus "/as sysdba"
SQL> alter system set
listener_networks='((NAME=network2) (LOCAL_LISTENER=LISTENER_IBLOCAL) (REMOTE_LISTEN
ER=LISTENER_IBREMOTE))',
'((NAME=network1) (LOCAL_LISTENER=LISTENER_10GBELOCAL) (REMOTE_LISTENER=LISTENER_10G
BEREMOTE))' scope=both;
SQL> alter system register;

```

Step 14. Connect the SAP instances to Oracle RAC

14a) Define the database services for the SAP application instances

Every SAP application instance uses a unique database service for the connection to the database. The creation of the services is done on an Oracle RAC node as user oracle. In our example we logon to node 1 etc4-cn01.

Example: Definition of database service (-s) QO1_DVEBMGS for database (-d) QO1 for primary SAP application instance. This database instance is configured to be available on instance (-r) QO11, with the ability to fail over to available instances (-a) QO12, QO13 or QO14.

```

# srvctl add service -d QO1 -s QO1_DVEBMGS -r QO11 -a QO12,QO13,QO14 -P \ BASIC -y
AUTOMATIC -q true -j long -e SELECT -m BASIC -z 3 -w 5

```

Add a service for each application instance (D51 to D58) and put them on different preferred RAC instances.

```

# srvctl add service -d QO1 -s QO1_D51 -r QO11 -a QO12,QO13,QO14 -P \ BASIC -y
AUTOMATIC -q true -j long -e SELECT -m BASIC -z 3 -w 5

# srvctl add service -d QO1 -s QO1_D52 -r QO12 -a QO13,QO14,QO11 -P \ BASIC -y
AUTOMATIC -q true -j long -e SELECT -m BASIC -z 3 -w 5

```

```
# srvctl add service -d Q01 -s Q01_D53 -r Q013 -a Q014,Q011,Q012 -P \ BASIC -y
AUTOMATIC -q true -j long -e SELECT -m BASIC -z 3 -w 5

# srvctl add service -d Q01 -s Q01_D54 -r Q014 -a Q011,Q012,Q013 -P \ BASIC -y
AUTOMATIC -q true -j long -e SELECT -m BASIC -z 3 -w 5

# srvctl add service -d Q01 -s Q01_D55 -r Q011 -a Q012,Q013,Q014 -P \ BASIC -y
AUTOMATIC -q true -j long -e SELECT -m BASIC -z 3 -w 5

# srvctl add service -d Q01 -s Q01_D56 -r Q012 -a Q013,Q014,Q011 -P \ BASIC -y
AUTOMATIC -q true -j long -e SELECT -m BASIC -z 3 -w 5

# srvctl add service -d Q01 -s Q01_D57 -r Q013 -a Q014,Q011,Q012 -P \ BASIC -y
AUTOMATIC -q true -j long -e SELECT -m BASIC -z 3 -w 5

# srvctl add service -d Q01 -s Q01_D58 -r Q014 -a Q011,Q012,Q013 -P \ BASIC -y
AUTOMATIC -q true -j long -e SELECT -m BASIC -z 3 -w 5
```

Start the services:

```
# srvctl start service -d Q01
```

Check the status of the services:

```
# srvctl status service -d Q01

oracle@etc4-cn01:~$ srvctl status service -d Q01
Service Q01_D51 is running on instance(s) Q011
Service Q01_D52 is running on instance(s) Q012
Service Q01_D53 is running on instance(s) Q013
Service Q01_D54 is running on instance(s) Q014
Service Q01_D55 is running on instance(s) Q011
Service Q01_D56 is running on instance(s) Q012
Service Q01_D57 is running on instance(s) Q013
Service Q01_D58 is running on instance(s) Q014
Service Q01_DVEBMGS00 is running on instance(s) Q011
```

Check the status of the database:

```
# srvctl status database -d Q01

oracle@etc4-cn01:~$ srvctl status database -d Q01
Instance Q011 is running on node etc4-cn01
Instance Q012 is running on node etc4-cn02
Instance Q013 is running on node etc4-cn03
Instance Q014 is running on node etc4-cn04
```

14b) Modify tnsnames.ora

Modify the file `/sapmnt/Q01/profile/oracle/tnsnames.ora` to add the Oracle database connect descriptors for the SAP instances. Here is an example for Q01_D51 and Q01_D52. The same needs to be done for Q01_D51 to Q01_D58.

```
#####
# Filename.....: tnsnames.ora
# Created.....: created by SAP AG, R/3 Rel. >= 6.10
# Name.....:
# Date.....:
# @(#) $Id: //bas/720_REL/src/krn/tpls/ora/TNSNAMES.ORA#1 $
```

```
# Modified manually for Oracle RAC over Infiniband
# Generally we use RAC VIP listeners on IPoIB instead of SCAN
#####

Q01.WORLD=
  (DESCRIPTION =
    (ADDRESS_LIST =
      (ADDRESS =
        (COMMUNITY = SAP.WORLD)
        (PROTOCOL = TCP)
        (HOST = etc4-01-ib-vip)
        (PORT = 1521)
      )
      (ADDRESS =
        (COMMUNITY = SAP.WORLD)
        (PROTOCOL = TCP)
        (HOST = etc4-02-ib-vip)
        (PORT = 1521)
      )
      (ADDRESS =
        (COMMUNITY = SAP.WORLD)
        (PROTOCOL = TCP)
        (HOST = etc4-03-ib-vip)
        (PORT = 1521)
      )
      (ADDRESS =
        (COMMUNITY = SAP.WORLD)
        (PROTOCOL = TCP)
        (HOST = etc4-04-ib-vip)
        (PORT = 1521)
      )
    )
    (CONNECT_DATA =
      (SERVICE_NAME = Q01)
      (GLOBAL_NAME = Q01)
      (FAILOVER_MODE =
        (TYPE = SELECT)
        (METHOD = BASIC)
      )
    )
  )
)
Q011.WORLD=
  (DESCRIPTION =
    (ADDRESS_LIST =
      (ADDRESS = (PROTOCOL = TCP) (HOST = etc4-01-ib-vip) (PORT = 1521))
    )
    (CONNECT_DATA =
      (SERVICE_NAME = Q011)
      (GLOBAL_NAME = Q01)
    )
  )
)
Q012.WORLD=
  (DESCRIPTION =
    (ADDRESS_LIST =
      (ADDRESS = (PROTOCOL = TCP) (HOST = etc4-02-ib-vip) (PORT = 1521))
    )
    (CONNECT_DATA =
      (SERVICE_NAME = Q012)
      (GLOBAL_NAME = Q01)
    )
  )
)
Q013.WORLD=
  (DESCRIPTION =
    (ADDRESS_LIST =
      (ADDRESS = (PROTOCOL = TCP) (HOST = etc4-03-ib-vip) (PORT = 1521))
    )
    (CONNECT_DATA =
      (SERVICE_NAME = Q013)
      (GLOBAL_NAME = Q01)
    )
  )
)
```

```

Q014.WORLD=
  (DESCRIPTION =
    (ADDRESS_LIST =
      (ADDRESS = (PROTOCOL = TCP) (HOST = etc4-04-ib-vip) (PORT = 1521))
    )
    (CONNECT_DATA =
      (SERVICE_NAME = Q014)
      (GLOBAL_NAME = Q01)
    )
  )
Q01_DVEBMGS00.WORLD=
  (DESCRIPTION =
    (ADDRESS_LIST =
      (FAILOVER = on)
      (LOAD_BALANCE = off)
      (ADDRESS = (PROTOCOL=TCP) (HOST= etc4-01-ib-vip) (PORT=1521))
      (ADDRESS = (PROTOCOL=TCP) (HOST= etc4-02-ib-vip) (PORT=1521))
      (ADDRESS = (PROTOCOL=TCP) (HOST= etc4-03-ib-vip) (PORT=1521))
      (ADDRESS = (PROTOCOL=TCP) (HOST= etc4-04-ib-vip) (PORT=1521))
    )
    (CONNECT_DATA =
      (SERVICE_NAME = Q01_DVEBMGS00)
      (GLOBAL_NAME = Q01)
      (FAILOVER_MODE=
        (TYPE=SELECT)
        (METHOD=BASIC)
      )
    )
  )
)
Q01_D51.WORLD=
  (DESCRIPTION =
    (ADDRESS_LIST =
      (FAILOVER = on)
      (LOAD_BALANCE = off)
      (ADDRESS = (PROTOCOL=TCP) (HOST= etc4-01-ib-vip) (PORT=1521))
      (ADDRESS = (PROTOCOL=TCP) (HOST= etc4-02-ib-vip) (PORT=1521))
      (ADDRESS = (PROTOCOL=TCP) (HOST= etc4-03-ib-vip) (PORT=1521))
      (ADDRESS = (PROTOCOL=TCP) (HOST= etc4-04-ib-vip) (PORT=1521))
    )
    (CONNECT_DATA =
      (SERVICE_NAME = Q01_D51)
      (GLOBAL_NAME = Q01)
      (FAILOVER_MODE=
        (TYPE=SELECT)
        (METHOD=BASIC)
      )
    )
  )
)
Q01_D52.WORLD=
  (DESCRIPTION =
    (ADDRESS_LIST =
      (FAILOVER = on)
      (LOAD_BALANCE = off)
      (ADDRESS = (PROTOCOL=TCP) (HOST= etc4-02-ib-vip) (PORT=1521))
      (ADDRESS = (PROTOCOL=TCP) (HOST= etc4-03-ib-vip) (PORT=1521))
      (ADDRESS = (PROTOCOL=TCP) (HOST= etc4-04-ib-vip) (PORT=1521))
      (ADDRESS = (PROTOCOL=TCP) (HOST= etc4-01-ib-vip) (PORT=1521))
    )
    (CONNECT_DATA =
      (SERVICE_NAME = Q01_D52)
      (GLOBAL_NAME = Q01)
      (FAILOVER_MODE=
        (TYPE=SELECT)
        (METHOD=BASIC)
      )
    )
  )
)
)
[... ..]

```

To set the connection between a SAP instance and an Oracle RAC instance via services, also add the following parameters in the SAP start profile and instance profile. For example, the SAP application instance DVEBMGS00 connects to Oracle RAC via service QO1_DVEBMGS00:

The instance profile QO1_DVEBMGS00_epas-lh:

```
db5/ora/tnsname = QO1_DVEBMGS00
```

The start profile START_DVEBMGS00_epas-lh:

```
SETENV_05 = db5 ora tnsname=QO1_DVEBMGS00
```

The SAP application instance D51 connects to Oracle RAC via service QO1_D51:

The instance profile QO1_D51_eapp1-lh:

```
db5/ora/tnsname = QO1_D51
```

The start profile START_D51_eapp1-lh:

```
SETENV_05 = db5 ora tnsname=QO1_D51
```

Using the same method, add the parameters in the instance profile and start profile for every SAP instance with its own RAC service.

Step 15. Move the Connections from 10 GbE to InfiniBand

15a) Move the ASCS connections to InfiniBand

To move ASCS connections to InfiniBand, modify the profile parameter SAPLOCALHOST in QO1_ASCS00_escs-lh and START_ASCS00_escs-lh as follows:

```
SAPLOCALHOST = iscs-lh
```

Modify the profile parameter in DEFAULT.PFL as follows:

```
SAPGLOBALHOST = iscs-lh
rdisp/mshost = iscs-lh
enqueue/serverhost = iscs-lh
```

15b) Move the Central Instance connections to InfiniBand

To move the central instance connections to InfiniBand, modify the profile parameter SAPLOCALHOST in QO1_DVEBMGS00_epas-lh and START_DVEBMGS00_epas-lh as follows:

```
SAPLOCALHOST = ipas-lh
```

15c) Move the App server connections to InfiniBand

To move the application server connections to InfiniBand, modify the profile parameter `SAPLOCALHOST` to the InfiniBand logical hosts.

15d) Use FQDNs in the hosts file

Double check the file `/etc/hosts` on all affected zones, making sure that the InfiniBand logical hosts entries have their fully qualified domain name after the simple hostnames.

```
192.168.30.45 iscs-lh iscs-lh.example.domain.com
192.168.30.46 irep-lh irep-lh.example.domain.com
192.168.30.55 iapp1-lh iapp1-lh.example.domain.com
192.168.30.56 iapp2-lh iapp2-lh.example.domain.com
192.168.30.57 iapp3-lh iapp3-lh.example.domain.com
192.168.30.58 iapp4-lh iapp4-lh.example.domain.com
192.168.30.65 ipas-lh ipas-lh.example.domain.com
```

15e) Check the connections

Restart the SAP system; ensure that the instances are connected among themselves and to the database via InfiniBand. For example, on host `iscs-lh`, execute the following commands to check that the ASCS instance is connected to the database via InfiniBand. IP addresses in the `192.*.*.*` subnet are InfiniBand connections. You may also use the `grep` command to make sure that there is no connection left on 10 GbE.

```
iscs1:# ps -efa | grep ms.sapQ01_ASCS00
  qoladm 1475 1460 0 Aug 28 ?          1:18 ms.sapQ01_ASCS00
pf=/usr/sap/Q01/SYS/profile/Q01_ASCS00_escs-lh

iscs1:/# pfiles 1475 | grep 192
  sockname: AF_INET 192.168.30.45 port: 3900
  peername: AF_INET 192.168.30.61 port: 42198
  sockname: AF_INET 192.168.30.45 port: 3900
  peername: AF_INET 192.168.30.61 port: 42298
  sockname: AF_INET 192.168.30.45 port: 3900
  peername: AF_INET 192.168.30.52 port: 39217
  sockname: AF_INET 192.168.30.45 port: 3900
  peername: AF_INET 192.168.30.54 port: 61912
  sockname: AF_INET 192.168.30.45 port: 3900
  peername: AF_INET 192.168.30.54 port: 61913
  .....
  .....
```

The process and its open files are communicating on the InfiniBand network.

Step 16. SAP Resource Creation

The resource groups and resources configuration are identical for ABAP and Java Systems. The following example is for SAP system `QO1`, which is an ABAP only ERP system.

16a) Preparation for HA SCS and ERS after Installation

The following is performed in the ASCS/ERS zone cluster as user `root`.

On all the other zones in the zone cluster where the instance may fail over to, copy the following files from the installation zone:

```
/etc/services
```

If a script was created on the installation zone to add groups and users, it can be re-used on all other zones that the instances may fail over to. Check that the following files are the identical to the files in the installation zone.

```
/etc/group
/etc/passwd
/etc/project
/etc/user_attr
```

Note: SAP system users must always have the same uids on all the zones they may run.

- Set the same password for the users on all zones.
- Copy all the user environment files from the installation zone to the other zones where the instance may fail over to in the zone cluster. The following command copies the whole /export/home folder.

```
tar cfB - /export/home |ssh root@<target zone> tar xfB -
```

- Log on as user q01adm, create wrapper scripts in the home folder of q01adm for the cluster agent to start and stop the SAP instances. Create these wrapper scripts for every instance. Stop/Start the instances with the wrapper scripts as q01adm user. Copy these scripts to all the zones where the instance may fail over to.

```
Example wrapper script to start the instance ASCS00:
file name: /export/home/q01adm/sapstartASCS
#####
kill -9 ` /usr/ucb/ps -auxww|grep Q01|grep ASCS00|grep -v startsap|grep -v grep|awk
'{print $2}' `
/usr/sap/Q01/SYS/exe/run/startsap r3 ASCS00 escs-lh
```

```
Example wrapper script to stop the instance ASCS00:
file name: /export/home/q01adm/sapstopASCS
#####
/usr/sap/Q01/SYS/exe/run/stopsap r3 ASCS00 escs-lh
kill -9 ` /usr/ucb/ps -auxww|grep Q01|grep ASCS00|grep -v stopsap|grep -v grep|awk
'{print $2}' `
/usr/sap/Q01/SYS/exe/run/cleanipc 00 remove
```

- Switch the logical hosts with resource groups for testing reason. For example:

```
# clrg status
# clrs status
# clrg switch -n iscs1 scs-rg
```

- Logon the host as user qo1adm where the logical host is running, start and stop the instances with the wrapper script. For example:

```
iscsl:qo1adm % ./sapstartASCS
iscsl:qo1adm % ./sapstopASCS
```

- Switch logical host to each zone in the cluster and verify that the SAP instances can be started/stopped correctly by the wrapper scripts.
- No wrapper scripts are required for the ERS instance(s) since the enrepsrver process(es) will be directly started by the cluster agent.

16b) Enable HA for message server, enqueue server and enqueue replication server

Stop all the SAP instances, do not stop the database.

Log on as user root, register the resource types in the specific local zone. For example in the scs-zc:

```
# clrt register sapenq
# clrt register saprepl
# clrt register sapscs
```

Create the message server resource

```
# clrs create -d -g scs-rg -t sapscs \
-p sap_sid=Q01 \
-p sap_instance_number=00 \
-p sap_instance_name=ASCS00 \
-p msg_server_port=3900 \
-p scs_startup_script=/export/home/qo1adm/sapstartASCS \
-p scs_shutdown_script=/export/home/qo1adm/sapstopASCS \
-p resource_dependencies=escs-lh \
abapmsg-rs
```

Bring all the resources into managed and online state.

```
# clrg online -eM +
```

Check that all the instance processes are running.

Since the enqueue server process will be directly started by the cluster agent, remove the start program of the enqueue server from the start profile /sapmnt/Q01/profile/START_<ASCS>_<logicalhost>. Only comment out the last line of the start program, but leave the lines above as they are. For example:

```
-----
# Start SAP enqueue server
-----
EN = en.sap$(SAPSYSTEMNAME) $(INSTANCE_NAME)
Execute_03 = local rm -f $( _EN)
Execute_04 = local ln -s -f $(DIR_EXECUTABLE)/enserver$(FT_EXE) $( _EN)
#Restart_Program_01 = local $( _EN) pf=$( _PF)
```

```
#-----
```

Disable the message server resource and enable it again. Verify that the enqueue server process is not restarted.

```
# clrs disable abapmsg-rs
# clrs enable abapmsg-rs
```

Create the enqueue resource

```
# clrs create -d -g scs-rg -t sapenq \
-p enqueue_profile=/sapmnt/Q01/profile/Q01_ASCS00_escs-lh \
-p enqueue_server=/usr/sap/Q01/SYS/exe/run/enserver \
-p sap_user=q0ladm -p enqueue_instance_number=00 \
-p resource_dependencies=escs-lh \
abapenq-rs
```

Bring all the resources into managed and online state.

```
# clrg online -eM +
```

Check that the enqueue server process enserver is running

```
# ps -ef | grep -i sap | grep -i enserver
```

Modify the ERS profile /sapmnt/Q01/profile/Q01_<ERS>_<logicalhost> to set the same instance number as the enqueue server ASCS. With the same instance number, the replication table in the shared memory will be automatically taken over by the enqueue server in case of failover. For example:

```
#SAPSYSTEM = 10
SAPSYSTEM = 00
```

Modify the ERS start profile /sapmnt/Q01/profile/START_<ERS>_<logicalhost>. Comment out the last line of the start ERS instance, for example:

```
#-----
# Start enqueue replication server
#-----
_ER = er.sap$(SAPSYSTEMNAME)_$(INSTANCE_NAME)
Execute_02 = local rm -f $( _ER)
Execute_03 = local ln -s -f $(DIR EXECUTABLE)/enrepserver$(FT_EXE) $( _ER)
#Restart Program 00 = local $( _ER) pf=$( PFL) NR=$(SCSID)
```

To make sure that the enqueue server and the enqueue replication sever are automatically reconnected after a network failure, modify the ASCS and ERS instance profiles to add following line:

```
enqueue/enrep/keepalive_count = 1
```

Setting the parameter enqueue/enrep/keepalive to 1 tells the enqueue server to send a keepalive package to the enqueue replication server periodically, and wait for an answer to determine, that the connection to the ERS is not lost unnoticed.

Next we need to set resource group affinities to ensure that the enqueue server and replication server run on different nodes and that the enqueue server always failover to the node where the enqueue replication server is running.

```
# clrg set -p rg_affinities=--scs-rg rep-rg
# clrg set -p rg_affinities=+rep-rg scs-rg
```

Create the enqueue replication server resource:

```
# clrs create -d -g rep-rg -t saprepl \
-p replica_profile=/sapmnt/Q01/profile/Q01_ERS10_erep-lh \
-p replica_server=/usr/sap/Q01/SYS/exe/run/enrepserver \
-p sap_user=qoladm \
-p resource_dependencies=erep-lh, abapenq-rs \
abaprepenq-rs
```

Bring all the resources into managed and online state.

```
# clrg online -eM +
```

Check the enqueue replication server process enrepserver is running

```
# ps -ef | grep -i sap | grep -i enrepserver
```

Switch the resources and check that the processes are failed over to the correct node. The enqueue replication resource group (rep-rg) should not run on the same node as the enqueue resource group (scs-rg). The scs-rg should always failover to the node where rep-rg was running.

```
# clrg switch -n <node> <resource group>
```

16c) Preparation for HA for the Primary Application Server (former CI)

The following steps are performed in the pas-zc zone cluster (for Primary Application Servers, formerly named Central Instance) as user root unless otherwise stated.

On all the other zones in the zone cluster where the instance may fail over to, copy following files from the installation zone:

```
/etc/services
```

If a script was created in the installation zone to add groups and users, it can be re-used in all other zones that the instances may fail over to. Ensure that the following files are the same as in the installation zone.

```
/etc/group
/etc/passwd
/etc/project
/etc/user_attr
```

Note: SAP system users must always have the same uids on all the zones it may run.

Set the same password for the users on all zones.

Copy all the user environment files from the installation zone to other zones where the instance may fail over to in the zone cluster. The following command copies the whole /export/home folder.

```
tar cfB - /export/home |ssh root@<target zone> tar xfB -
```

Log on as user qo1adm and create wrapper scripts in the home folder of qo1adm for the cluster agent to start/stop the SAP instances. Create these wrapper scripts for each instance. Stop/Start the instances with the wrapper scripts as user qo1adm. Copy these scripts to all the zones where the instance may fail over to.

```
Example wrapper script to start the instance DVEBMGS00:
file name: /export/home/qo1adm/sapstartPAS
#####
kill -9 ` /usr/ucb/ps -auxww|grep Q01|grep DVEBMGS00|grep -v startsap|grep -v
grep|awk '{print $2}' `
/usr/sap/Q01/SYS/exe/run/cleanipc 00 remove
/usr/sap/Q01/SYS/exe/run/startsap r3 DVEBMGS00 epas-lh
```

```
Example wrapper script to stop the instance DVEBMGS00:
file name: /export/home/qo1adm/sapstopPAS
#####
/usr/sap/Q01/SYS/exe/run/stopsap r3 DVEBMGS00 epas-lh
kill -9 ` /usr/ucb/ps -auxww|grep Q01|grep DVEBMGS00|grep -v stopsap|grep -v
grep|awk '{print $2}' `
/usr/sap/Q01/SYS/exe/run/cleanipc 00 remove
```

Note the difference between sapstartASCS and sapstartPAS. There can be a cleanipc before starting the instance DVEBMGS00 in sapstartPAS but do not in sapstartASCS, or the lock table in shared memory would be deleted and the enqueue server would not get the lock table data from the enqueue replication server while failing over.

Switch the logical hosts with resource groups for testing reason. For example:

```
# clrg status
# clr status
# clrg switch -n ipas3 pas-rg
```

Logon to the host as user q01adm where the logical host is running, start and stop the instances with your wrapper script. Verify that the instance is started/stopped successfully. For example:

```
ipas3:q01adm % ./sapstartPAS
ipas3:q01adm % ./sapstopPAS
```

Switch the logical host to each zone in the cluster and verify that the SAP instances can be started/stopped correctly using the wrapper script.

16d) Enable HA for the Primary Application Server

Stop all the SAP instances, do not stop the database.

Log on as user root and register the resource types in the specific local zone. For example in the pas-zc:

```
# clrt register sapwebas
```

Create the primary application server resource

```
# clrs create -d -g pas-rg -t sapwebas \
-p failover mode=HARD \
-p sap_sid=Q01 \
-p sap_instance_number=00 \
-p sap_instance_name=DVEBMGS00 \
-p sap_user=q01adm \
-p resource_project_name=Q01 \
-p sap_instance_type=ABAP \
-p webas_startup_script=/export/home/q01adm/sapstartPAS \
-p webas_shutdown_script=/export/home/q01adm/sapstopPAS \
-p sap_logdir=/usr/sap/Q01/DVEBMGS00/work \
-p webas_use_pmf=true \
-p resource_dependencies=epas-lh \
abap-pas-rs
```

Bring the resources to Managed and Online States

Bring all the resources into managed and online state in the zone cluster.

```
# clrg online -eM +
```

Verify that all the instance processes are running.

Get the resource status from the global zone with command “clrg status”

Switch the resources and make sure that the processes are failed over to the correct node.

16e) Configure Oracle Solaris Cluster HA for SAP AAS as failover resources

The additional application servers use the same resource type as the primary application server.

Log on as superuser in one of the nodes in the cluster that hosts the SAP instances.

Create the wrapper scripts `/export/home/q01adm/sapstartD51` and `/export/home/q01adm/sapstopD51` for starting/stopping SAP instance D51. Verify that they are working on all the zones where the instance is going to switch to.

```
iapps1:q01adm 268% cat sapstartD51
kill -9 ` /usr/ucb/ps -auxww|grep Q01|grep D51|grep -v sapstart|grep -v
startsap|grep -v grep|awk '{print $2}' `
/usr/sap/Q01/SYS/exe/run/cleanipc 51 remove
/usr/sap/Q01/SYS/exe/run/startsap R3 D51 eapp1-lh
```

```
iapps1:q01adm 269% cat sapstopD51
/usr/sap/Q01/SYS/exe/run/stopsap R3 D51 eapp1-lh
kill -9 ` /usr/ucb/ps -auxww|grep Q01|grep D51|grep -v sapstop|grep -v stopsap|grep
-v grep|awk '{print $2}' `
/usr/sap/Q01/SYS/exe/run/cleanipc 51 remove
```

Create the resource D51-rs in the failover resource group D51-rg.

```
# clrs create -d -g D51-rg -t sapwebas \
-p sap_sid=Q01 \
-p sap_instance_number=51 \
-p sap_instance_name=D51 \
-p sap_user=q01adm \
-p resource_project_name=Q01 \
-p sap_instance_type=ABAP \
-p webas_startup_script=/export/q01adm/sapstartD51 \
-p webas_shutdown_script=/export/q01adm/sapstopD51 \
-p sap_logdir=/usr/sap/Q01/D51/work \
-p webas_use_pmf=true \
D51-rs
```

Manage the resource group and enable the resources to take the SAP application server instances online.

```
# clrg online -eM D51-rg
```

Repeat the steps above to create failover resources for all the other SAP application server instances D52 – D58.

16f) Operation and Trouble Shooting

Check the status of the SAP Application Server Instances

Log on host `apps-zc` as root and execute the command “`clrs status`” to get the status of the instances:

```
# ssh root@eapps1
Password:
Last login: Mon Apr 23 07:34:09 2012 from epas3
Oracle Corporation      SunOS 5.10      Generic Patch   January 2005
# bash
iapps1:/# clrs status
```

Start/Stop a single SAP Application Server Instance

Logon on host apps-zc as root and execute command “clrs disable <resource>” to stop the instance. Execute the command “clrs enable <resource>” to start the instance.

Get the status of the resources:

```
iapps1:/# clrs status
```

To shut down instance D57 on node1

```
iapps1:/# clrs disable D57-rs
```

To start instance D57 on node1

```
iapps1:/# clrs enable D57-rs
```

Get the resource status from the global zone

Get the resource status from the global zone with command “clrg status -Z <zone>”

```
etc4-01-appl:/# clrg status -Z all
```

If a resource group is in “Error_stop_failed” status, logon to the local zone and fix the problem. Then clear the flag “Stop_failed” of the resource, and restart the resources from the local zone. Use “clrs status” to check the status of the resources.

```
# clrs status
# clrs clear <resource>
# clrg online +
```

Alternatively, the flag from the global zone can be cleared:

```
etc4-01-appl:/# clrs status -Z scs-zc -g scs-rg
etc4-01-appl:/# clrs clear -Z scs-zc abapmsg-rs
etc4-01-appl:/# clrg online -Z scs-zc +
```

If a resource group is in “Error_start_failed” status, restart the resource group on the same node or switch it to another node. The flag will be cleared automatically.

To restart the resource group:

```
etc4-01-appl:/# clrg restart -Z scs-zc scs-rg
```

To switch the resource group:

```
etc4-01-appl:/# clrg switch -n iscs2 -Z scs-zc scs-rg
```

At this point all the SAP components have been installed and configured and verified functional in their respective zone clusters.

Final Zone Cluster Setup

Step 17. Finalize the Storage Configuration

After the central services are installed and configured under Oracle Solaris Cluster, complete the storage configuration with the following:

```
# clrg set -p RG_affinities+==+scalmnt-rg scs-rg
# clrg set -p RG_affinities+==+scalmnt-rg rep-rg
# clrs set -p Resource_dependencies_offline_restart+=sapmnt-fs-rs,usrsap-fs-
rs,trans-fs-rs abapeng-rs
# clrs set -p Resource_dependencies_offline_restart+=sapmnt-fs-rs,usrsap-fs-
rs,trans-fs-rs abapmsg-rs
# clrs set -p Resource_dependencies_offline_restart+=sapmnt-fs-rs,usrsap-fs-
rs,trans-fs-rs abaprepenq-rs
```

After the primary instance is installed and configured under Oracle Solaris Cluster, complete the storage configuration with the following:

```
# clrg set -p RG_affinities+==+scalmnt-rg pas-rg
# clrs set -p Resource_dependencies_offline_restart+=ora-fs-rs,sapmnt-fs-
rs,usrsap-fs-rs,trans-fs-rs abap-pas-rs
```

After the additional dialogue instances are installed and configured under Oracle Solaris Cluster, complete the storage configuration with the following:

```
# clrg set -p RG_affinities+==+scalmnt-rg D51-rg D52-rg D53-rg D54-rg D55-rg D56-
rg D57-rg D58-rg
# clrs set -p Resource_dependencies_offline_restart+=ora-fs-rs,sapmnt-fs-rs,trans-
fs-rs,usrsap-fs-rs -t SUNW.sapwebas +
```

Step 18. Configure the Oracle External Proxy resource

Configure the Oracle External Proxy resource in the SPARC SuperCluster zone cluster. This step is performed after the database for SAP has been configured as a RAC database running in the database domains, and that the connectivity to the database via InfiniBand has been configured.

First add the monitoring user and access privileges to the database in the DB domains, from one database node:

```
-bash-3.00$ sqlplus "/as sysdba"
SQL> create user hauser identified by hauser;
SQL> grant create session to hauser;
SQL> grant execute on dbms_lock to hauser;
SQL> grant select on v_$instance to hauser;
SQL> create profile hauser limit PASSWORD_LIFE_TIME UNLIMITED;
SQL> alter user hauser identified by hauser profile hauser;
SQL> exit
```

In the scs-zc zone cluster, create a `/var/opt/oracle/tnsnames.ora` file on each node `iscs1`, `iscs2`, `iscs3` and `iscs4`, as follows:

```

iscs1:/# cat /var/opt/oracle/tnsnames.ora
Q01 =
  (DESCRIPTION =
    (ADDRESS_LIST =
      (ADDRESS = (PROTOCOL = TCP) (HOST = etc4-01-ib-vip) (PORT = 1521))
      (ADDRESS = (PROTOCOL = TCP) (HOST = etc4-02-ib-vip) (PORT = 1521))
      (ADDRESS = (PROTOCOL = TCP) (HOST = etc4-03-ib-vip) (PORT = 1521))
      (ADDRESS = (PROTOCOL = TCP) (HOST = etc4-04-ib-vip) (PORT = 1521))
    )
    (CONNECT_DATA =
      (SERVER = DEDICATED)
      (SERVICE_NAME = q01)
    )
  )
)

```

Create an encrypted password file on iscs1, iscs2, iscs3 and iscs4, as follows:

```

iscs1:/# dd if=/dev/urandom of=/var/cluster/scoep_key bs=8 count=1

iscs1:/# echo hauser | /usr/sfw/bin/openssl enc -aes128 -e -pass
file:/var/cluster/scoep_key -out /opt/ORCLscoep/.oep-rs_passwd

```

Verify that the encrypted password can be decrypted.

```

iscs1:/# /usr/sfw/bin/openssl enc -aes128 -d -pass file:/var/cluster/scoep_key -in
/opt/ORCLscoep/.oep-rs_passwd
hauser

iscs1:/# chmod 400 /var/cluster/scoep_key
iscs1:/# chmod 400 /opt/ORCLscoep/.oep-rs_passwd

```

Create the Resource group and resource from one zone cluster node.

```

iscs1:/# clrt register -f /opt/ORCLscoep/etc/ORCL.oracle_external_proxy
ORCL.oracle_external_proxy
iscs1:/# clrg create -S oep-rg
iscs1:/# clrs create -g oep-rg -t ORCL.oracle_external_proxy \
-p service_name=q01 \
-p ons_nodes=etc4-01-ib-vip:6200,etc4-02-ib-vip:6200,etc4-03-ib-vip:6200,etc4-
04-ib-vip:6200 \
-p dbuser=hauser -d oep-rs

iscs1:/# clrg online -eM oep-rg
iscs1:/# clrs status -g oep-rg

=== Cluster Resources ===

Resource Name      Node Name      State      Status Message
-----
oep-rs             iscs1          Online     Online - Service q01 is UP
                   iscs2          Online     Online - Service q01 is UP
                   iscs3          Online     Online - Service q01 is UP
                   iscs4          Online     Online - Service q01 is UP

```

Step 19. Configure the cross-zone clusters dependencies

Configure the cross-zone clusters dependencies to coordinate availability between domains and zone clusters.

In the scs-zc zone cluster

```
# clrs set -p Resource_dependencies+=oep-rs abapenq-rs
# clrs set -p Resource_dependencies+=oep-rs abapmsg-rs
```

From the global zone:

```
# clrs set -Z pas-zc -p Resource_dependencies+=scs-zc:oep-rs,scs-zc:abapmsg-rs
abap-pas-rs

# for i in 51 52 53 54 55 56 57 58
do
set -x
clrs set -Z apps-zc -p Resource_dependencies+=scs-zc:oep-rs,scs-zc:abapmsg-rs
D"$i"-rs
set +x
done
```

Step 20. Configure CPU resource control for the zone clusters

In this example, the zone clusters for SCS and PAS would need just 0.5 T4 core (=4 threads) and the Apps would need 4 cores (=32 threads).

From the global zone of one node:

```
# clzc configure scs-zc
clzc:scs-zc> add dedicated-cpu
clzc:scs-zc:dedicated-cpu> set ncpus=4
clzc:scs-zc:dedicated-cpu> set importance=20
clzc:scs-zc:dedicated-cpu> end
clzc:scs-zc> exit
# clzc configure pas-zc
clzc:pas-zc> add dedicated-cpu
clzc:pas-zc:dedicated-cpu> set ncpus=4
clzc:pas-zc:dedicated-cpu> set importance=20
clzc:pas-zc:dedicated-cpu> end
clzc:pas-zc> exit
# clzc configure apps-zc
clzc:apps-zc> add dedicated-cpu
clzc:apps-zc:dedicated-cpu> set ncpus=32
clzc:apps-zc:dedicated-cpu> set importance=20
clzc:apps-zc:dedicated-cpu> end
clzc:apps-zc> exit

# clzc halt apps-zc pas-zc scs-zc
# clzc boot scs-zc pas-zc apps-zc
# poolstat
```

id	pool	size	pset used	load
7	SUNWtmp_apps-zc	32	0.00	0.39
0	pool_default	88	0.00	0.08
3	SUNWtmp_pas-zc	4	0.00	0.00
2	SUNWtmp_scs-zc	4	0.00	0.01

Step 21. Configure Policy-based Failover

During availability testing, we observed that overload situations could be created during major failures that impacted the performance of all SAP services, regardless of their level of criticality (See the Availability Test section in the Oracle Technical Whitepaper “How to Improve the Efficiency and Performance of an SAP Environment with the Oracle Optimized Solution for SAP”). During the most dramatic failure scenarios, the post-failure workloads showed severe

performance degradation caused too many application server instances with too many users running on each surviving node.

To remediate the performance degradation it was decided to limit and control the impact on the most business-critical applications by implementing, load-based, application-specific failover policies. The policies were configured as follows:

1. Based on previous testing, a policy was implemented limiting the number of SAP application server instances to a maximum of three per node.
2. A policy was configured that assigned a priority and load capacity to each application instances.

The failover policies were configured as follows:

- Highest priority level (30) applied to application instances D51, D52, and D53
- Medium priority level (20) applied to application instance D54
- Low priority level (10) applied to application instances D55, D56, D57, and D58

```
# clnode create-loadlimit -p limitname=cpu_load -p softlimit=24 -p hardlimit=28 +
# clrg set -p load_factors=cpu_load@8 -p priority=30 -p preemption_mode=Never D51-
rg D52-rg D53-rg
# clrg set -p load_factors=cpu_load@8 -p priority=20 -p preemption_mode=Has_cost
D54-rg
# clrg set -p load_factors=cpu_load@8 -p priority=10 -p preemption_mode=Has_cost
D55-rg D56-rg D57-rg D58-rg
```

References and Documentation

ORACLE WEB PAGES

The Oracle Optimized Solution for SAP	http://www.oracle.com/us/solutions/oos/sap/overview/index.html
Oracle Advanced Customer Support Services (ACS)	http://www.oracle.com/us/support/software/advanced-customer-services/index.html
Oracle Database and IT Infrastructure for SAP	http://www.oracle.com/sap
Oracle for SAP Resources	http://www.oracle.com/us/solutions/sap/database/oracle-sap-resources-303416.html
Oracle IT Infrastructure for SAP Resources	http://www.oracle.com/us/solutions/sap/infrastructure/sap-resources-352184.html
Oracle Engineered Systems	http://www.oracle.com/us/products/engineered-systems/index.html
Oracle SPARC Systems	http://www.oracle.com/us/products/servers-storage/servers/sparc-enterprise/overview/index.html
Oracle Storage and Tape Systems	http://www.oracle.com/us/products/storage/overview/index.html
Oracle Solaris	http://www.oracle.com/us/products/servers-storage/solaris/overview/index.html
Oracle Solaris Cluster	http://www.oracle.com/us/products/servers-storage/solaris/cluster/overview/index.html

SAP WEB PAGES

SAP on Oracle	http://scn.sap.com/community/oracle
Featured Content for SAP on Oracle	http://scn.sap.com/docs/DOC-23461
SAP on Oracle Solaris	http://scn.sap.com/community/oracle-solaris
Key SAP Notes for SAP on Oracle	http://scn.sap.com/docs/DOC-8664
Key SAP Notes for SAP on Oracle Solaris	http://scn.sap.com/docs/DOC-23511
SAP on Oracle Real Application Clusters - RACs	http://scn.sap.com/docs/DOC-8835
SAP on Oracle Installation and Upgrade	http://scn.sap.com/docs/DOC-7888
SAP on Oracle - Performance	http://scn.sap.com/docs/DOC-8000

WHITE PAPERS, ARTICLES, BEST PRACTICES

SAP on Oracle White Papers	http://scn.sap.com/docs/DOC-8752
Best Practices for Migrating SAP Environments	http://www.oracle.com/technetwork/articles/systems-hardware-architecture/sap-migration-163923.pdf
Configuring Sun Storage 7000 Unified Storage Systems for Oracle® Databases	http://www.oracle.com/technetwork/articles/systems-hardware-architecture/ss700-config-oracle-db-163902.pdf

Optimizing Storage in SAP with Oracle Database 11g Release 2	http://www.oracle.com/technetwork/database/focus-areas/performance/sapstorageoptimization-335322.pdf
High Availability with the Standalone Enqueue Server	http://help.sap.com/saphelp_nw04s/helpdata/en/6d/e3a03cc24efd1de10000000a114084/content.htm
SPARC SuperCluster T4-4 Platform Security Principles and Capabilities	http://www.oracle.com/us/products/servers-storage/servers/sparc-enterprise/supercluster/supercluster-t4-4/ssc-security-pac-1716580.pdf

DOCUMENTATION AND GUIDES

Sun Cluster Data Service for SAP Web Application Server Guide for Solaris OS	http://docs.oracle.com/cd/E19316-01/820-2568/index.html
Installing and Configuring HA for SAP	http://docs.oracle.com/cd/E19680-01/html/821-1536/behgdfff.html
Installing and Configuring HA for SAP Web Application Server	http://docs.oracle.com/cd/E19680-01/html/821-1538/installconfig-1.html
Oracle Solaris Cluster Concepts Guide	http://docs.oracle.com/cd/E19680-01/html/821-1254/index.html
Oracle Database Quick Installation Guide 11g Release 2 for Oracle Solaris on SPARC	http://docs.oracle.com/cd/E11882_01/install.112/e24349/toc.htm



Deployment Guide for Highly Available SAP on
Oracle SPARC SuperCluster
Original September 2012
Updated January 2013
Authors: Pierre Reynes ; Gia-Khanh Nguyen ;
Hans-Juergen Denecke ; Xirui Yang

Oracle Corporation
World Headquarters
500 Oracle Parkway
Redwood Shores, CA 94065
U.S.A.

Worldwide Inquiries:
Phone: +1.650.506.7000
Fax: +1.650.506.7200
oracle.com



Oracle is committed to developing practices and products that help protect the environment

Copyright © 2013, Oracle and/or its affiliates. All rights reserved. This document is provided for information purposes only and the contents hereof are subject to change without notice. This document is not warranted to be error-free, nor subject to any other warranties or conditions, whether expressed orally or implied in law, including implied warranties and conditions of merchantability or fitness for a particular purpose. We specifically disclaim any liability with respect to this document and no contractual obligations are formed either directly or indirectly by this document. This document may not be reproduced or transmitted in any form or by any means, electronic or mechanical, for any purpose, without our prior written permission.

Oracle and Java are registered trademarks of Oracle and/or its affiliates. Other names may be trademarks of their respective owners.

AMD, Opteron, the AMD logo, and the AMD Opteron logo are trademarks or registered trademarks of Advanced Micro Devices. Intel and Intel Xeon are trademarks or registered trademarks of Intel Corporation. All SPARC trademarks are used under license and are trademarks or registered trademarks of SPARC International, Inc. UNIX is a registered trademark licensed through X/Open Company, Ltd. 0110

SOFTWARE. HARDWARE. COMPLETE.