



An Oracle Deployment Guide
September 2011

Deploying a Converged Network Using Oracle CNAs and a Brocade FCoE Switch

Disclaimer

Information furnished in this manual is believed to be accurate and reliable. However, Oracle assumes no responsibility for its use, nor for any infringements of patents or other rights of third parties which may result from its use. Oracle reserves the right to change product specifications at any time without notice. Applications described in this document for any of these products are for illustrative purposes only. Oracle makes no representation or warranty that such applications are suitable for the specified use without further testing or modification. Oracle assumes no responsibility for any errors that may appear in this document.

TABLE OF CONTENTS

Documentation Conventions.....	4
Introduction	5
Intended Audience	6
Planning	7
Selecting a Test Architecture	7
Organizational Ownership Fibre Channel/Storage, Ethernet/Networking	7
Where and How to Deploy	7
Architecture	8
Process Summary	8
Reference Architecture Description	8
Architecture Overview	8
Equipment Details	9
Installation	9
Determine Configuration.....	10
Install the Converged Network Adapter Hardware	10
Install the Adapter Drivers	11
Windows and Linux	11
Solaris	11
Install SANsurfer Fibre Channel HBA Manager	11
Cabling	11
Configure Fibre Channel Switches and Zoning.....	11
Configure Storage	14
Verify Equipment Connectivity.....	14
Conclusion	20
Appendix A: FCoE and Enhanced Ethernet Related Materials	21
Appendix B: Hardware and Software.....	22
Sun Storage 10 GbE FCoE PCIe Converged Network Adapter	22
Oracle's Sun ZFS Storage Appliance	22

Brocade 8000 DCB/FCoE Switch	22
Appendix C: Oracle Converged Network Adapter Overview	23
Kit Contents.....	23
Converged Network Adapter Features and Specifications	23
Operating System and Technology Requirements.....	25
System Interoperability	25
Host Platform Support	26
Storage Support	26
Array Support	27
Disk System Support.....	27
Tape Storage Support.....	27
Switch Support	27
Software Support.....	28
Boot Support.....	28
Environmental Requirements.....	28
Appendix D: Data Center Bridging Technology.....	29
Data Center Bridging (DCB)	29
DCBX and ETS.....	29
Priority Flow Control	29
Fibre Channel over Ethernet (FCoE).....	30
iSCSI.....	30
Appendix E: References	31

Documentation Conventions

This guide uses the following documentation conventions:

- ***CAUTION!*** indicates the presence of a hazard that has the potential of causing damage to data or equipment.
- ***WARNING!!*** indicates the presence of a hazard that has the potential of causing personal injury.
- Text in **blue** font indicates a hyperlink (jump) to a figure, table, or section in this guide, and links to Web sites are shown in **underlined blue**.
- Text in **bold** font indicates user interface elements such as a menu items, buttons, check boxes, or column headings. For example:

Click the **Start** button, point to **Programs**, point to **Accessories**, and then click **Command Prompt**.

- Text in **Courier** font indicates a file name, directory path, or command line text. For example:

To return to the root directory from anywhere in the file structure: Type `cd /root` and press ENTER.

- Key names and key strokes are indicated with UPPERCASE:

Press CTRL+P.

Press the UP ARROW key.

- Text in *italics* indicates terms, emphasis, variables, or document titles. For example:

For a complete listing of license agreements, refer to the *Oracle Software End User License Agreement*.

- Topic titles between quotation marks identify related topics either within this manual or in the online help, which is also referred to as *the help system* throughout this document.

Introduction

In the *Unified Data Center Fabric Primer: FCoE and Data Center Bridging* publication, a converged network is defined as a unified data center fabric:

"A unified data center fabric is a networking fabric that combines traditional LAN and storage area network (SAN) traffic on the same physical network with the aim of reducing architecture complexity and enhancing data flow and access. To make this work, the traditional Ethernet network must be upgraded to become *lossless* and provide additional data center networking features and functions. In turn, the storage protocol must be altered to run on Ethernet."

Demartek, Dennis Martin, *Unified Data Center Fabric Primer: FCoE and Data Center Bridging*, SearchNetworking.com, 2010.

Lossless means that no Fibre Channel packets are dropped.

This document describes how to install a converged fabric. This configuration demonstrates lossless Ethernet and data center bridging (DCB), which includes priority flow control (PFC), enhanced transmission selection (ETS), and data center bridging Exchange protocol (DCBX) for a Fibre Channel and 10Gb Ethernet unified fabric.

Deploying an Oracle® converged fabric reduces the cost and complexity of maintaining multiple networks, allows administrators to manage more data and larger storage networks with the same or fewer resources, and controls rising power and cooling costs by eliminating redundant hardware. Additionally, implementing an Oracle converged fabric allows the IT staff to support data growth and data center sprawl.

With an Oracle converged fabric, standard TCP/IP and Fibre Channel traffic share the same high-speed 10 Gb/s Ethernet wire, resulting in cost savings through reduced adapter, switch, cabling, power, cooling, and management requirements. Fibre Channel over Ethernet (FCoE) has rapidly gained market acceptance because it delivers excellent performance, reduces data center total cost of ownership (TCO), and protects current data center investments. An Oracle converged fabric with FCoE preserves existing investments in Fibre Channel and Ethernet while providing Enhanced Ethernet for unified data networking. Implementing an Oracle converged fabric enables businesses to achieve up to a 150% performance improvement over 4Gb Fibre Channel, reduce capital expenditures by reducing server and media costs, and deliver up to a 33% space savings over a four-year period. The following figure illustrates the basic efficiency from consolidation.



FIGURE 1 ILLUSTRATION OF EFFICIENCY OF CONVERGING

Intended Audience

This guide is intended for system engineers and planners who want to provide converged networking products, solutions, and services to their customers. It is also intended for network planners and administrators who are implementing a converged network for their company. This guide describes how to install an Oracle converged network in preparation for production deployment.

The guide provides system engineers, architects, and end users with a step-by-step method to implement a unified fabric and measure performance of a pilot operation. This guide does not provide methods to measure performance under load or to contrast performance between various protocols, media types, or file systems. This guide is intended to assist in implementing a converged fabric using current storage and protocols.

This guide assumes the use of existing storage and Fibre Channel switches, and therefore, does not describe switch and storage configuration in detail. This guide also assumes a basic knowledge of Enhanced Ethernet and the associated standards. If you are not familiar with FCoE and Enhanced Ethernet, review the documents listed in “Appendix A: FCoE and Enhanced Ethernet Related Materials” on page 21.

Planning

Selecting a Test Architecture

When planning to install a converged network, it is important to choose both Fibre Channel and traditional Ethernet-based traffic flows. Combining a test SAN infrastructure and a test LAN infrastructure is often the easiest and most available option for a pilot project. Alternatively, a critical business application test system can closely simulate a production environment. The architecture you choose to start with must demonstrate that a converged network improves efficiency and performance in your environment. You will need to substitute your own equipment and modify the installation process accordingly.

Organizational Ownership Fibre Channel/Storage, Ethernet/Networking

A critical factor for successfully implementing a converged data center fabric is the stability of network and storage management practices. Cooperation between the system, network, and storage management teams is important in configuring the converged data center fabric.

Where and How to Deploy

A unified fabric has two components:

- 10Gb Ethernet switches that support Data Center Bridge (DCB) and FCoE—These switches support the connection of traditional Ethernet and Fibre Channel infrastructures. These switches are known as top-of-rack (TOR) switches, implementing DCB and encapsulating Fibre Channel frames into Ethernet frames for transport over 10Gb Ethernet media.
- 10Gb Converged Network Adapters that support both Ethernet LAN and Fibre Channel SAN over 10Gb Ethernet media—These adapters replace the NIC and Fibre Channel host bus adapter, and connect to a DCB-enabled 10Gb Ethernet switch.

Currently, a Converged Network Adapter must always be connected to a switch that has DCB. There are two types of switches that have DCB: a DCB switch and an FCoE switch. The DCB switch has enhanced Ethernet support, but does not have Fibre Channel forwarder (FCF) capabilities and does not support the conversion of Fibre Channel frames to FCoE frames. A DCB switch supports converging Ethernet-based protocols, but does not support Fibre Channel protocols. The DCB switch requires an external device to manage Fibre Channel and FCoE functions. An FCoE switch supports both DCB and Fibre Channel.

There are three ways to connect Fibre Channel storage to a unified fabric:

- Converged Network Adapter > FCoE switch > Fibre Channel switch > Fibre Channel storage

The adapter connects to the FCoE switch with Ethernet infrastructure, and the FCoE switch connects to storage through a Fibre Channel switch. This is the most common implementation in today's data centers because the Fibre Channel switch and SAN storage are typically already in place.

- Converged Network Adapter > DCB switch > FCF > Fibre Channel switch > Fibre Channel storage

The DCB switch requires an external device to provide the FCF function to the attached Fibre Channel storage. This approach is not as common because most data centers do not have an FCF device, and they will acquire an FCoE switch to connect to their Fibre Channel Infrastructure.

- Converged Network Adapter > FCoE switch > FCoE storage:

This implementation is not common because most data centers use Fibre Channel SAN storage. As more storage vendors deliver FCoE storage, more pilot projects will support direct Ethernet connection from the FCoE switch to FCoE-capable storage controllers.

In all cases, Ethernet LAN and iSCSI storage connect directly to Ethernet ports on the DCB or FCoE switch.

The reference architecture, shown in Figure 2, uses Fibre Channel SAN storage. For information about installing the reference architecture, see “Installation” on page 9.

Architecture

Process Summary

A converged network was installed in a validated Oracle environment. Screen shots and command line interface (CLI) images were captured to show the installation process.

Reference Architecture Description

Architecture Overview

Figure 2 illustrates the converged infrastructure that was installed. Fibre Channel storage traffic and LAN traffic, which shared the unified 10GbE bandwidth driven by Converged Network Adapters, was installed.

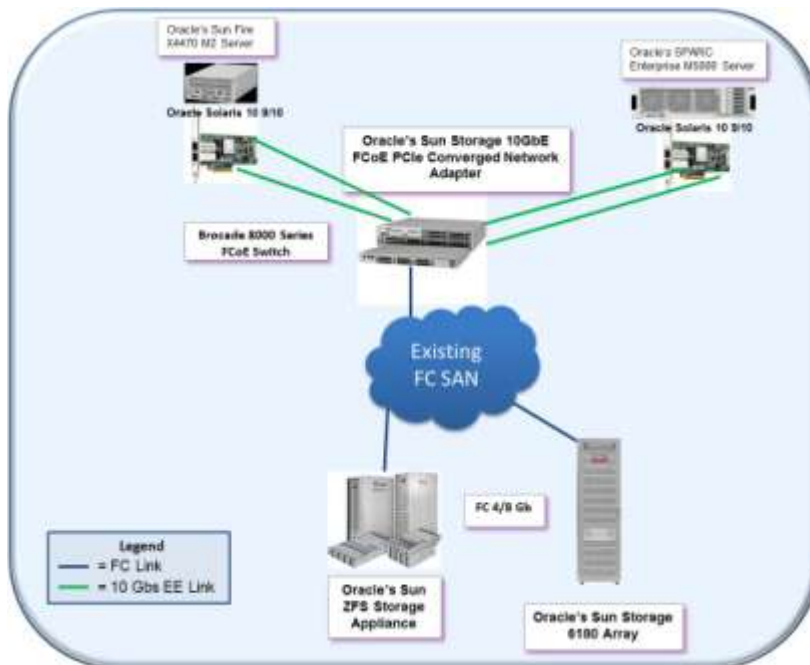

FIGURE 2 REFERENCE ARCHITECTURE DIAGRAM

Equipment Details

Table 1 lists the referenced architecture equipment.

Two Sun™ servers from Oracle were installed with Oracle Solaris 10 9/10. All servers used Oracle's Sun Storage 10 GbE FCoE PCIe Converged Network Adapter. One Sun ZFS Storage Appliance from Oracle and one Sun Storage 6000 Series Storage Array from Oracle provided the FC SAN storage.

TABLE 1 CONVERGED NETWORK INVENTORY

QUANTITY	PRODUCT	MODEL NUMBER
2	One Sun Fire X4470 M2 Server and one SPARC Enterprise M5000 (both with Oracle Solaris 10 9/10)	Such as Sun Fire X4270 M2 Server Sun Fire X4470 M2 Server Sun Fire X4800 Server SPARC Enterprise M5000 Server
2	Sun Storage 10GbE FCoE PCIe Converged Network Adapter	SG-(X)PCIEFCOE2-Q-SR (short range optics) SG-(X)PCIEFCOE2-Q-TA (twin-axial copper) SG-(X)EMFCOE2-Q-SR, (short range optics) SG-(X)EMFCOE2-Q-TA (twin-axial copper)
1	Brocade® 8000 FCoE switch	
1	Sun ZFS Storage Appliance	Sun ZFS-Storage 7000 Series
1	Sun Storage 6000 Series Array	Sun Storage 6180 Array

Installation

This section describes how to set up an FCoE environment. It assumes a general understanding of SAN administration concepts. The installation process consists of the following steps:

1. Determine the configuration.
2. Install CNAs.
3. Configure switches and zoning so that CNAs and storage can see each other.
4. Configure storage to assign LUNs to CNAs.
5. Verify equipment connectivity.

Determine the Configuration

Sun Storage 10 GbE FCoE PCIe Converged Network Adapters are supported on multiple hardware platforms and operating systems. Generally, the following specifications apply, but you should always check the Oracle Web site for current information. This configuration uses a subset of the following equipment:

- Server bus interface: PCIe® Gen1 x8 or PCIe Gen2 x4
- Hardware platforms: x86 or SPARC
- Storage—the following storage systems are in most data centers:
 - Fibre Channel
 - iSCSI
- FCoE configuration
- Switches—The following switches are typical in this configuration:
 - Fibre Channel
 - FCoE
 - Ethernet
- Cabling
 - Fiber optic cable (OM2/OM3) between servers, switches, and storage
 - Cat5e and Cat6 Ethernet for device management and 1GbE iSCSI storage

Install the Converged Network Adapter Hardware

Begin by identifying a server that meets Converged Network Adapter hardware requirements (PCI slot type, length, available slot) and install the adapters.

To install the adapter hardware:

1. Use a ground strap to avoid damaging the card or server.
2. Power off the computer and disconnect the power cable.
3. Remove the computer cover and find an empty PCIe x8 bus slot (Gen1) or PCIe x4 bus slot (Gen2).
4. Pull out the slot cover (if any) by removing the screw or releasing the lever.
5. Install the low-profile bracket, if required.
6. Grasp the adapter by the top edge, and then insert it firmly into the appropriate slot.
7. Refasten the adapter's retaining bracket using the existing screw or lever.
8. Close the computer cover.
9. Plug the appropriate Ethernet cable (either copper or optical) into the adapter. Optical models ship with optical transceivers installed. Go to the Oracle compatibility Web site for a listing of approved copper cables.
10. Plug in the power cable, and turn on the computer.

For detailed installation instructions, see the [Sun Storage 10GbE FCoE PCIe Converged Network Adapter Installation Guide](#).

Install the Adapter Drivers

Oracle Solaris, Microsoft Windows and Linux

To install the FCoE and Ethernet drivers for Solaris, Windows[®] and Linux[®]:

1. Navigate to http://driverdownloads.qlogic.com/QLogicDriverDownloads_UI/SunOEM.aspx?oemid=124.
2. At the bottom of the table **Enterprise 10Gb Fibre Channel over Ethernet Converged Network Adapter**, select your OS from the row labeled **Software for**:
 - a. For Oracle Solaris, download and install the latest QLC and Ethernet drivers for Oracle Solaris.
 - b. For Windows, download and install the latest NDIS (Ethernet) and STOR (FCoE) drivers.
 - c. For Linux, download and install the CNA driver for your distro.
3. Follow the included instructions for installing the downloaded driver.

Install SANsurfer Fibre Channel HBA Manager

To install the SANsurfer[®] Fibre Channel HBA Manager:

1. Navigate to http://driverdownloads.qlogic.com/QLogicDriverDownloads_UI/SunOEM.aspx?oemid=124.
2. At the bottom of the table “**Enterprise 10Gb Fibre Channel over Ethernet Converged Network Adapter**”, select your OS from the row labeled, “**Software for:**”
 - a. For Oracle Solaris, download and install the latest Oracle x86 or SPARC patches for the SANsurfer SCLI.
 - b. For Windows, download and install the latest SANsurfer
 - c. For Linux, download and install the latest SANsurfer for your distro.
3. Follow the included instructions for installing the downloaded software.

Cabling

To connect the Fibre Channel and Ethernet cables:

1. Connect the Fibre Channel cables from the servers to the Brocade 8000 FCoE switch.
2. Connect the Fibre Channel cables from the storage to the Brocade 8000. FCoE switch.
3. Connect any necessary Ethernet cables for device management and iSCSI storage.

Configure Fibre Channel Switches and Zoning

If you are connecting Fibre Channel devices, such as storage, through a Fibre Channel switch, then you must connect the Fibre Channel switch to a Fibre Channel port on the FCoE switch. In addition, set up a zoning configuration so that the servers can discover the disk LUNs you are mapping. For zoning instructions, see the Fibre Channel switch documentation.

In this procedure, you may need to adjust some of the parameters, such as VLAN IDs, Ethernet interfaces, and virtual Fibre Channel interfaces to suit your environment. In this example, the Brocade FCF uses NIC traffic on priority 2 and VLAN 2, and FCoE traffic on priority 3 and VLAN 1002.

To configure a Brocade 8000 FCoE Switch:

1. Login to switch and enter FCoE command shell.

```
BR8K-21 login: admin  
Password: *****  
BR8K-21:admin> cmsh           Use cmsh to enter FCoE command mode
```

2. Enter the configuration mode.

```
BR8K-21-cmsh# config t       Use configure terminal to enter config mode
```

3. Create and configure the VLAN interface for FCoE.

```
BR8K-21-cmsh (config) # int vlan 3           Create VLAN 3  
BR8K-21:admin (conf-if-vl-3) # fcf forward    Enable FCoE traffic on VLAN 3  
BR8K-21:admin (conf-if-vl-3) # exit         Exit VLAN 3 I/F
```

4. Create the VLAN classifier rules. These are used to enable FCoE and FIP protocols.

```
BR8K-21-cmsh (config) # vlan classifier rule 1 proto fcoe encap ethv2  
BR8K-21-cmsh (config) # vlan classifier rule 2 proto fip encap ethv2
```

5. Create the VLAN classifier group and add classifier rules. These are used to enable FCoE and FIP protocols.

```
BR8K-21-cmsh (config) # vlan classifier group 1 add rule 1  
BR8K-21-cmsh (config) # vlan classifier group 1 add rule 2
```

6. Create and configure CEE-MAP. CEE Map is used to configure Enhanced Transmission Selection (ETS) and Priority Flow Control (PFC).

```
BR8K-21-cmsh (config) # cee-map demo  
BR8K-21-cmsh (conf-ceemap) # priority-group-table 1 weight 50 pfc  
BR8K-21-cmsh (conf-ceemap) # priority-group-table 2 weight 50
```

NOTE:

- `pfc` enables priority flow control for this priority group, which will be our FCoE priority group.
- PFC may not be supported for non-FCoE traffic, depending on the vendor
- `weight` defines the percentage of bandwidth this traffic will get

7. Define Priority Group mapping for groups 0 – 7.

```
BR8K-21-cmsh (conf-ceemap) # priority-table 2 2 2 1 2 2 2 2
```

NOTE: COS: 0 1 2 **3** 4 5 6 7

NOTE: COS 3 is the default for FCoE. Don't try to change it, because the rest of the world is expecting it to be COS 3.

8. Configure LLDP/DCBX for FCoE.

```
BR8K-21-cmsh (config) #protocol lldp  
BR8K-21-cmsh (conf-lldp) # advertise dcbx-fcoe-app-tlv1  
BR8K-21-cmsh (conf-lldp) # advertise dcbx-fcoe-logical-link-tlv2
```

NOTE:

¹ Advertises the DCBX FCoE application TLV

² Advertises the DCBX FCoE logical link TLV

DCBX: Data Center Bridging Exchange protocol. Creates a lossless communication environment.

TLV: Type Length Value. Mandatory LLDP data structures within the Ethernet frame, including chassis ID, Port ID, time to live, and so on.

9. Configure CEE port for FCoE.

```
BR8K-21-cmsh (config) #int te 0/0  
BR8K-21-cmsh (conf-if-te-0/0) #switchport Enable L2 switching mode  
BR8K-21-cmsh (conf-if-te-0/0) #switchport mode converged3  
BR8K-21-cmsh (conf-if-te-0/0) #switchport converged allowed vlan add 3  
Enable VLAN 3 on this I/F  
BR8K-21-cmsh (conf-if-te-0/0) # vlan classifier activate group 1 vlan 34  
BR8K-21-cmsh (conf-if-te-0/0) # cee demo Assign CEE map to port  
BR8K-21-cmsh (conf-if-te-0/0) # no shut Enable the port
```

NOTE:

³ I/F could be untagged (access) in one VLAN and tagged (trunk) in another VLAN. Trunk allows multiple VLAN associations and tagged frames. Converged allows both.

⁴ Activate group 1 rule on this port for VLAN 3 (defined earlier)

10. Verify CNA is logged into the switch.

```
BR8K-21-cmsh (conf-if-te-0/0) #do fos switchshow Look for logged-in VN-Ports.  
BR8K-21-cmsh (conf-if-te-0/0) #do fos nsshow Look for expected FC/FCoE devices  
BR8K-21-cmsh (conf-if-te-0/0) #exit Exit port config  
BR8K-21-cmsh (config) #exit Exit config mode
```

11. Save your configuration.

```
BR8K-21-cmsh#copy run start  
BR8K-21-cmsh#exit Exit cmsh mode  
BR8K-21:admin> Return to FOS
```

Saving the configuration copies the running configuration to the startup configuration, which is preserved across reboots. The running configuration is a temporary copy and is lost during a reboot.

Configure Storage

Depending on your storage, you may connect directly to the FCoE switch through FCoE with native FCoE storage, or through other methods (Fibre Channel, iSCSI, NFS, CIFS). Consult your storage array documentation for instructions on how to enable your array and assign disk storage LUNs. The storage installed for this report was two 4 Gb Fibre Channel storage systems (a Sun ZFS Storage Appliance and a Sun Storage 6180 Array).

Verify Equipment Connectivity

When the LUNs have been created and all zoning is complete, use the management interface to add the WWNs of the Converged Network Adapter Fibre Channel initiators to your storage so that the servers can discover the LUNs.

1. The screen captures in Figure 3 show the LUN assignments for the ZFS Storage Appliance and the Oracle Sun Storage 6180 Array.

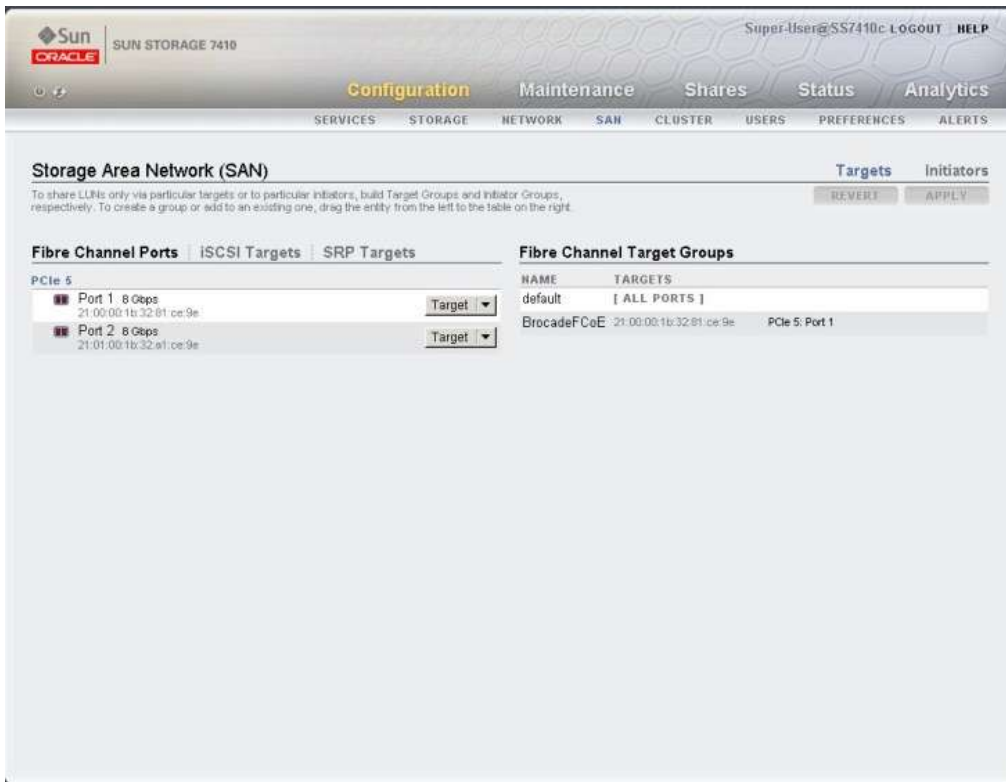

Sun ORACLE SUN STORAGE 7410 Super-User@SS7410c LOGOUT HELP

Configuration Maintenance **Shares** Status Analytics

SHARES PROJECTS SCHEMA

Projects All Projects

Usage 2.7% of 8.92T

Referenced data 250G
 Snapshot data 212M
 Total space 250G

Filesystems LUNs 2 Total

SHOW ALL LOCAL REPLICA

NAME	SIZE	GUID
default / FCoE-BrocadeM5000	110G	600144F0CDF7D7900004E385E050002
default / FCoE-BrocadeX4450	100G	600144F0CDF7D7900004E3850E40001

Sun ORACLE SUN STORAGE 7410 Super-User@SS7410c LOGOUT HELP

Configuration Maintenance Shares Status Analytics

SERVICES STORAGE NETWORK SAN CLUSTER USERS PREFERENCES ALERTS

Storage Area Network (SAN) Targets Initiators

To share LUNs only via particular targets or to particular initiators, build Target Groups and Initiator Groups, respectively. To create a group or add to an existing one, drag the entity from the left to the table on the right.

REVERT APPLY

Fibre Channel Initiators ISCSI Initiators SRP Initiators

Fibre Channel Initiator Groups

NAME	INITIATORS
default	[ALL INITIATORS]
M5000-1	21:00:00:c0:0d:14:60:cd M5000
X4450-1	21:00:00:c0:0d:14:60:c9 X4450



FIGURE 3 ZFS STORAGE APPLIANCE LUN ASSIGNMENT DISPLAY

2. Reboot the servers to discover the assigned LUNs.

On the SPARC Enterprise M5000 Server the following command is an intermediate check to ensure that the hardware is seeing the LUNs in a pre-boot environment. The following information is the LUN portion obtained from the SPARC Enterprise M5000 Server NVRAM display.

```
SPARC Enterprise M5000 Server, using Domain console
Copyright (c) 1998, 2010, Oracle and/or its affiliates. All rights
reserved.
Copyright (c) 2010, Oracle and/or its affiliates and Fujitsu Limited. All
rights reserved.
OpenBoot 4.24.15, 65536 MB memory installed, Serial #70949847.
Ethernet address 0:14:4f:3a:9b:d7, Host ID: 843a9bd7.
```

```
Aborting auto-boot sequence.
{0} ok show-devs
/pci@13,700000
:
:
:
/packages
/pci@12,600000/SUNW,qlc@0,3
/pci@12,600000/SUNW,qlc@0,2
/pci@12,600000/ethernet@0,1
/pci@12,600000/ethernet@0
/pci@12,600000/SUNW,qlc@0,3/fp@0,0
/pci@12,600000/SUNW,qlc@0,3/fp@0,0/disk
/pci@12,600000/SUNW,qlc@0,2/fp@0,0
/pci@12,600000/SUNW,qlc@0,2/fp@0,0/disk
:
:
:
/packages/SUNW,probe-error-handler
{0} ok
```

3. After booting Oracle Solaris on both systems, verify that the server operating system and the management application can discover the assigned LUNs. Verify the LUNs are present with the FC info HBA-port

command. Two approaches can be used. Native Oracle Solaris commands can be entered or the SANSurfer CLI can also be used.

The Oracle Solaris commands would be performed once on the Sun Fire server and once on the SPARC Enterprise M5000 Server.

```
SCX4450-BRM-03# fcinfo hba-port
```

```
HBA Port WWN: 210000c0dd1460c9
```

```
OS Device Name: /dev/cfg/c2
```

```
Manufacturer: QLogic Corp.
```

```
Model: 375-3681-01
```

```
Firmware Version: 05.04.03
```

```
FCode/BIOS Version: BIOS: 2.14; fcode: 3.10; EFI: 3.20;
```

```
Serial Number: 0402A00-1006527597
```

```
Driver Name: qlc
```

```
Driver Version: 20110321-3.05
```

```
Type: N-port
```

```
State: online
```

```
Supported Speeds: 10Gb
```

```
Current Speed: 10Gb
```

```
Node WWN: 200000c0dd1460c9
```

```
HBA Port WWN: 210000c0dd1460cb
```

```
OS Device Name: /dev/cfg/c3
```

```
Manufacturer: QLogic Corp.
```

```
Model: 375-3681-01
```

```
Firmware Version: 05.04.03
```

```
FCode/BIOS Version: BIOS: 2.14; fcode: 3.10; EFI: 3.20;
```

```
Serial Number: 0402A00-1006527597
```

```
Driver Name: qlc
```

```
Driver Version: 20110321-3.05
```

```
Type: unknown
```

```
State: offline
```

```
Supported Speeds: 10Gb
```

```
Current Speed: not established
```

```
Node WWN: 200000c0dd1460cb
```

```
SCX4450-BRM-03#
```

Alternatively, the following SANsurfer CLI commands can be used.

Scanning QLogic FC HBA(s) and device(s), please wait...

/

SANsurfer FC/CNA HBA CLI

v1.7.3 Build 37

Main Menu

- 1: General Information
- 2: HBA Information
- 3: HBA Parameters
- 4: Target/LUN List
- 5: Boot Device
- 6: Utilities
- 7: Beacon
- 8: Diagnostics
- 9: Statistics
- 10: Virtual
- 11: FCoE
- 12: Help
- 13: Exit

Enter Selection: **4**

SANsurfer FC/CNA HBA CLI

v1.7.3 Build 37

Target List Menu

HBA Model QLE8142-S

- 1: Port 1 (HBA 0 OS 0): WWPN: 21-00-00-C0-DD-14-60-C9 Online
- 2: Port 2 (HBA 1 OS 1): WWPN: 21-00-00-C0-DD-14-60-CB Link Down
- 3: All HBAs
- 4: Return to Previous Menu

Note: 0 to return to Main Menu

Enter Selection: **1**

SANsurfer FC/CNA HBA CLI

v1.7.3 Build 37

Target List Menu

HBA/OS Instance 0/0 (QLE8142-S Port 1) : Online

ENode MAC Addr: 00:C0:DD:14:60:C9

WWPN : 21-00-00-C0-DD-14-60-C9

Desc : QLE8142 SUN PCI Express to 10 GbE Dual Channel CNA

(FCoE)

- 1: Disk (Online)

```

Vendor                : SUN
Product ID            : SUN_6180
Product Rev           : 0760
Serial Number         : SQ02400384
Node Name             : 20-06-00-80-E5-18-48-B0
Port Name             : 20-16-00-80-E5-18-48-B0
Port ID               : 01-01-00

2: Disk (Online)
Vendor                : SUN
Product ID            : SUN_6180
Product Rev           : 0760
Serial Number         : SQ94600739
Node Name             : 20-06-00-80-E5-18-48-B0
Port Name             : 20-17-00-80-E5-18-48-B0
Port ID               : 01-02-00

3: Disk (Online)
Vendor                : SUN
Product ID            : Sun Storage 7410
Product Rev           : 1.0
Serial Number         :
Node Name             : 20-00-00-1B-32-81-CE-9E
Port Name             : 21-00-00-1B-32-81-CE-9E
Port ID               : 01-03-00

4: All Target(s)

5: Return to Previous Menu

```

4. Verify that you can access the LUNs with the format command.

```

SCX4450-BRM-03# format
Searching for disks...done

```

AVAILABLE DISK SELECTIONS:

```

0. c0t0d0 <DEFAULT cyl 17830 alt 2 hd 255 sec 63>
   /pci@0,0/pci8086,3607@4/pci108e,286@0/disk@0,0
1. c0t1d0 <DEFAULT cyl 17831 alt 2 hd 255 sec 63>
   /pci@0,0/pci8086,3607@4/pci108e,286@0/disk@1,0
2. c0t2d0 <DEFAULT cyl 17831 alt 2 hd 255 sec 63>
   /pci@0,0/pci8086,3607@4/pci108e,286@0/disk@2,0
3. c0t3d0 <DEFAULT cyl 17831 alt 2 hd 255 sec 63>
   /pci@0,0/pci8086,3607@4/pci108e,286@0/disk@3,0
4. c4t60080E500017E21600001BC54E37ECF1d0 <DEFAULT cyl 1303 alt 2 hd
255 sec 63>
   /scsi_vhci/disk@g60080e500017e21600001bc54e37ecf1
5. c4t600144F0CDCF7D7900004E385DE40001d0 <DEFAULT cyl 13052 alt 2 hd
255 sec 63>
   /scsi_vhci/disk@g600144f0cdf7d7900004e385de40001
Specify disk (enter its number):

```

```

SCX4450-BRM-03# luxadm -e port
/devices/pci@0,0/pci8086,3605@2/pci8086,3500@0/pci8086,3510@0/pci1077,183@0
,2/fp@0,0:devctl CONNECTED

```

```
/devices/pci@0,0/pci8086,3605@2/pci8086,3500@0/pci8086,3510@0/pci1077,183@0,3/fp@0,0:devctl NOT CONNECTED
SCX4450-BRM-03#
```

```
SCX4450-BRM-03# ./prtpicl | grep 1077
                pci1077,184 (obp-device, e6000001a8)
                pci1077,184 (obp-device, e6000001d0)
                pci1077,183 (obp-device, e6000001f8)
                pci1077,183 (obp-device, e600000256)
SCX4450-BRM-03#
```

Conclusion

This document summarizes how to plan for, manage, and implement an FCoE pilot. This step-by-step guide provides guidance on the implementation of a unified fabric. The reference architecture described in this guide was assembled from equipment that was available in the Oracle Solution Center located in Broomfield, Colorado. You will need to substitute your own equipment, and modify the installation and validation process based on your equipment and management tools.

Additional resources, a description of the equipment used, and DCB terms and definitions are available in the following appendixes.

Appendix A: FCoE and Enhanced Ethernet Related Materials

The following links provide more detailed information, and connect to the IEEE documents that define the Enhanced Ethernet functions:

- *P802.1Qbb (Draft 2.3): Priority-based Flow Control*
<http://www.ieee802.org/1/files/private/bb-drafts/d2/802-1bb-d2-3.pdf>
- *P802.1Qaz (Draft 2.5): Enhanced Transmission Selection*
<http://www.ieee802.org/1/files/private/az-drafts/d2/802-1az-d2-5.pdf>
- *P802.1Qaz (Draft 2.5): DCB Capability Exchange Protocol (DCBX)*
<http://www.ieee802.org/1/files/private/az-drafts/d2/802-1az-d2-5.pdf>
- *P802.1Qau (Draft 2.4): Congestion Notification*
<http://www.ieee802.org/1/files/private/au-drafts/d0/802-1au-d0-4.pdf>
- *P802.1Qbg and P802.1Qbh: Virtual Bridging*

The Ethernet Alliance has white papers that further describe Enhanced Ethernet:

http://www.ethernetalliance.org/library/ethernet_in_the_data_center/white_papers

Appendix B: Hardware and Software

Sun Storage 10 GbE FCoE PCIe Converged Network Adapter

The Sun Storage 10 GbE FCoE PCIe Converged Network Adapter is a single-chip, fully-offloaded FCoE initiator, operating in both virtual and non-virtual environments, running over an Enhanced Ethernet fabric. This converged network adapter initiator boosts system performance with 10Gbps speed and full hardware offload for FCoE protocol processing. Cutting-edge 10 Gbps bandwidth eliminates performance bottlenecks in the I/O path with a 10X data rate improvement over existing 1Gbps Ethernet solutions. In addition, full hardware offload for FCoE protocol processing reduces system CPU usage for I/O operations, which leads to faster application performance and greater consolidation in virtualized systems.

Sun ZFS Storage Appliance

Oracle's Sun ZFS Storage Appliance product line delivers leadership value for organizations using unified storage to implement cloud computing, virtualization, fixed-content serving, data-protection and storage-consolidation environments. The product line enables the rapid deployment of new revenue-producing applications and lowers expenses by reducing storage complexity and its associated administrative costs.

The Sun ZFS Storage Appliance product line combines industry-leading performance, density, and storage analytics with an innovative storage architecture and unparalleled ease of deployment and use.

Brocade 8000 DCB/FCoE Switch

The Brocade 8000 switch is a Layer 2, 32-port, 1U form factor top-of-rack switch with:

- Twenty-four 10 GbE DCB ports (see Figure 1) that support FCoE and provide line-rate, low-latency, lossless, deterministic connectivity based on Brocade 10 Gbps cut-through and non-blocking switching technology
- Eight 8 Gbps Fibre Channel ports with auto-sensing for 1, 2, 4, and 8 Gbps speeds

The Brocade 8000 switch provides flexible migration and deployment options with a DCB-only model that can be used as a top-of-rack switch for 10-GbE connectivity. This particular configuration provides a building block for future migration to FCoE. When the time is right, organizations simply enable the Fibre Channel ports and FCoE capabilities via an upgrade license to support converged server I/O.

The top-of-rack Brocade 8000 switch connects to server CNAs in server racks through DCB ports and connects to the storage infrastructure over the Fibre Channel ports. The CNAs encapsulate the Fibre Channel traffic destined for the storage networks as FCoE, and the IP traffic flows as 10 GbE frames to the 24 DCB ports on the Brocade 8000 switch. The switch then forwards traditional Ethernet-based IP traffic from the DCB ports onto the LAN, and it forwards the Fibre Channel data in Fibre Channel frames over the Fibre Channel ports to the SAN.

Appendix C: Converged Network Adapter Overview

This appendix provides a basic overview of the Sun Storage 10GbE FCoE PCIe Converged Network Adapter, which uses QLogic technology. This appendix also describes the various operating systems, storage, and infrastructure configurations that support the Converged Network Adapter, and lists the adapter's environmental requirements. Detailed information regarding the Sun Storage 10GbE PCIe Converged Network Adapter can be found at: <http://www.oracle.com/us/products/servers-storage/storage/storage-networking/sun-storage-10gbe-fcoe-pcie-cna-077975.html>.

This section contains the following topics:

- Kit Contents
- Converged Network Adapter Features and Specifications
- Operating System and Technology Requirements
- System Interoperability
- Environmental Requirements

Kit Contents

- Sun Storage 10GbE FCoE PCIe Converged Network Adapter
- Standard bracket
- *Accessing Documentation* document

Converged Network Adapter Features and Specifications

The Sun Storage 10GbE FCoE PCIe Converged Network Adapter is a standard low-profile, dual-port Converged Network Adapter that is available in two models:

- SG-(X)PCIEFCOE2-Q-SR—This model ships with two small form-factor pluggable plus (SFP+) short range (SR) optical modules and supports a maximum cabling distance of 300 meters over multimode fiber.
- SG-(X)PCIEFCOE2-Q-TA—This model is intended for use with SFP+ direct attach twin-axial copper cables, and supports a maximum cabling distance of 10 meters.

The following Express Modules are also available for the Sun Storage 10GbE FCoE PCIe Converged Network Adapter:

- SG-(X)EMFCOE2-Q-SR—This model ships with SFP+ short range optical modules and supports a maximum cabling distance of 300 meters over multimode fiber.
- SG-(X)EMFCOE2-Q-TA—This model is intended for use with SFP+ direct-attach twin-axial copper cables, and supports a maximum cabling distance of 10 meters.

CAUTION!—Do not replace any of the SFP+s connectors. Doing so will void the warranty or serviceability of the Converged Network Adapter.

Table 2 lists the features and specifications for this adapter.

TABLE 2 CONVERGED NETWORK ADAPTER FEATURES AND SPECIFICATIONS

FEATURE	DESCRIPTION
Form factor	Standard low-profile form factor
Connector types	SFP+ SR optics SFP+ direct-attach twin-axial copper
PCIe specification compliance	<i>PCI Express Card Version 2.0 Electromechanical Specification</i>
PCI training configurations	PCI Express Gen 2 x4 logical slot or PCI Express Gen 1 x8 logical slot PCIe hot-plug and hot swap functionality
Supported maximum power consumption	11 watts
Oracle Solaris Dynamic Reconfiguration (DR)	Supports Dynamic Reconfiguration, a software mechanism that allows resources to be attached (logically added) or detached (logically removed) from the Oracle Solaris operating environment control without incurring any system downtime
FCoE full offload in hardware requirement	Meets this requirement
Boot support (Ethernet and FCoE)	For all operating systems (see Table 3)
Receive side scaling (RSS)	Supported
MSI-X (message signaled interrupts)	Supported
Fibre Channel support	Support for dual-port FCoE compatible with: <ul style="list-style-type: none"> ▪ Fibre Channel Generic Services (FC-GS-3) ▪ Fibre Channel Tape and Medium Changers (FC-Tape) ▪ Fibre Channel Protocol for SCSI (FCP-3-SCSI) ▪ Fibre Channel Switch Fabric (FC-SW-4) ▪ Fabric Provided MAC Address (FPMA) support ▪ FCoE boot code for all supported operating systems

FEATURE	DESCRIPTION
Ethernet and NIC support	<p>Standard Ethernet and Enhanced Ethernet support for:</p> <ul style="list-style-type: none"> ▪ IEEE 802.1Q VLAN ▪ IEEE 802.1p ▪ IEEE 802.3x ▪ IEEE 802.1Qbb ▪ IEEE 802.1Qaz ▪ DCBX <p>Controller hardware support for:</p> <ul style="list-style-type: none"> ▪ Jumbo frames support for frame sizes of at least 9 Kbytes ▪ Hardware TCP/UDP checksum generation ▪ Hardware IPv4/IPv6 checksum offload ▪ Hardware Large Segmentation Offload ▪ Hardware Header and Data Split ▪ Full duplex operation ▪ Up to 128 MAC addresses ▪ Unicast and multicast address filtering ▪ VMware® NetQueue ▪ Packet filtering based on MAC address or VLAN tag ▪ Microsoft receive-side scaling (RSS) ▪ NIC teaming ▪ PCI hot-plug ▪ Preboot Execution Environment (PXE) boot ▪ FCode

Operating System and Technology Requirements

The Sun Storage 10GbE FCoE PCIe Converged Network Adapter requires the operating system (OS) and technology versions listed in Table 3. Please note that this guide shows Oracle Solaris OS support only. You can obtain the latest patches at: <http://support.oracle.com>.

TABLE 3 SUPPORTED OPERATING SYSTEM/TECHNOLOGY VERSIONS (MINIMUM)

OPERATING SYSTEM/TECHNOLOGY	SUPPORTED VERSIONS (MINIMUM)
Oracle Solaris 10 OS for the Oracle x86 (64-bit) platform	Oracle Solaris 10 10/09 with patches 143958-03 and 144487-03
Oracle Solaris 10 OS for the SPARC (64-bit) platform	Oracle Solaris 10 10/09 with patches 143957-03 and 144486-03

System Interoperability

This section provides information about platforms, storage systems, switches, and software that are compatible with the heterogeneous Fibre Channel and Ethernet network design of the Sun Storage 10GbE FCoE PCIe Converged Network Adapter. This section contains the following topics:

- Host Platform Support
- Storage Support

- Switch Support
- Software Support
- Boot Support

Host Platform Support

The adapter is supported by the platforms listed in Table 4. For up-to-date information, see your Oracle server release notes and Web pages.

TABLE 4 HOST PLATFORM SUPPORT

PLATFORM SUPPORTED	OS/TECHNOLOGY
Oracle SPARC Servers:	
Sun SPARC Enterprise M3000	Oracle Solaris
Sun SPARC Enterprise M4000	
Sun SPARC Enterprise M5000	
Sun SPARC Enterprise M8000	
Sun SPARC Enterprise M9000-32	
Sun SPARC Enterprise M9000-64	
Sun SPARC Enterprise T5120	
Sun SPARC Enterprise T5220	
Oracle x86 Servers:	
Sun Fire X2200 M2	Oracle Solaris, Linux, VMware, Virtual Machine, and Windows
Sun Fire X2250	
Sun Fire X2270	
Sun Fire X4140	
Sun Fire X4150	
Sun Fire X4170	
Sun Fire X4240	
Sun Fire X4250	
Sun Fire X4270	
Sun Fire X4275	
Sun Fire X4440	
Sun Fire X4450	
Sun Fire X4640	

Storage Support

This section lists the arrays, disk systems, and tape storage devices supported by the Sun Storage 10GbE FCoE PCIe Converged Network Adapter. This section provides the following topics:

- Array Support
- Disk System Support
- Tape Storage Support

Array Support

The Sun Storage 10GbE FCoE PCIe Converged Network Adapter supports connecting to, using a supported switch, the following arrays :

- Sun StorageTek 2540
- Sun StorageTek 6140
- Sun StorageTek 6180
- Sun StorageTek 6540
- Sun StorageTek 6580/6780 with 8Gb Fibre Channel host interface cards

Disk System Support

The Sun Storage 10GbE FCoE PCIe Converged Network Adapter supports connecting to, using a supported switch, the following disk system storage:

- Sun StorageTek 9980/9985/9985V System
- Sun StorageTek 9990/9990V System

Tape Storage Support

The Sun Storage 10GbE FCoE PCIe Converged Network Adapter supports connecting to, using a supported switch, the following tape storage devices:

- Sun StorageTek SL24 tape autoloader
- Sun StorageTek SL48 tape library
- Sun StorageTek SL500 modular library
- Sun StorageTek SL3000 modular library
- Sun StorageTek SL8500 modular library
- Sun StorageTek L1400 tape library
- Sun StorageTek T10000A and T10000B tape drives
- Sun StorageTek 9840C and 9840D tape drives
- Sun StorageTek LTO-5 tape drive
- IBM LTO3 and LTO4 tape drives
- Quantum DLT-S4 tape drive

Switch Support

The Sun Storage 10GbE FCoE PCIe Converged Network Adapter supports connecting to the following Fibre Channel over Ethernet (FCoE) switches:

CAUTION!—When operating with Oracle’s Solaris 10 10/09, logging into a Brocade Elara 8000 switch requires VLAN 1002 configuration for that port. This is not a requirement in later versions of the Oracle Solaris operating system.

Software Support

The Con Sun Storage 10GbE FCoE PCIe Converged Network Adapter supports the software utilities and applications listed in Table 5 and Table 6.

TABLE 5 SUPPORTED CONVERGED NETWORK ADAPTER UTILITIES

SOFTWARE	SUPPORTED OS
Converged Network Adapter firmware update utility	Oracle Solaris, Linux, VMware, and Windows
Converged Network Adapter configuration and management utility	Oracle Solaris, Linux, VMware, and Windows
Oracle Solaris <code>fcinfo</code> utility compatibility	Oracle Solaris

TABLE 6 OTHER SUPPORTED SOFTWARE APPLICATIONS

SOFTWARE	SUPPORTED OS
Veritas™ Storage Foundation (VxSF) 5.0	Oracle Solaris
Veritas NetBackup 6.5	Oracle Solaris
Sun StorageTek™ Enterprise Backup Software (EBS) 7.2/7.3/7.4	Oracle Solaris, Linux, and Windows
Support for native multipathing	Oracle Solaris, Linux, and Windows

Boot Support

The Converged Network Adapter supports the following minimum boot types:

- Oracle Solaris 10 x86 (Oracle Solaris 10 10/09)
- Oracle Solaris 10 SPARC (Oracle Solaris 10 10/09)
- Preboot Execution Environment (PXE) boot capable (for Oracle x86 systems)
- Linux (RHEL, SLES, and Oracle Linux)
- Oracle VM 2.2.1

Environmental Requirements

The Sun Storage 10GbE FCoE PCIe Converged Network Adapter environmental requirements are listed in Table 7.

TABLE 7 Sun Storage 10GbE FCOE PCIe Converged Network Adapter Environmental Requirements

SPECIFICATION	OPERATING	NON-OPERATING
Temperature	0C° to 55°C, noncondensing	–40°C to 70°C, noncondensing
Humidity	10% RH to 90% RH, noncondensing, 27°C max wet bulb	93% RH, noncondensing, 38°C max wet bulb
Altitude	3000m	12,000m

SPECIFICATION	OPERATING	NON-OPERATING
Vibration	0.20G in all axes, 5-500 Hz sine	1.0G in all axes, 5–500 Hz sine
Shock	5G, 11 ms half-sine	30G 11 ms half-sine

Appendix D: Data Center Bridging Technology

The following descriptions of Enhanced Ethernet were taken from *Ethernet: The Converged Network Ethernet Alliance Demonstration* which was presented at the Super Computing 2009 (SC09) conference and published by the Ethernet Alliance in November, 2009.

Data Center Bridging (DCB)

For Ethernet to carry LAN, SAN and IPC traffic together and achieve network convergence, some necessary enhancements are required. These enhancement protocols are summarized as data center bridging (DCB) protocols, also referred to as Enhanced Ethernet (EE), which are defined by the IEEE 802.1 data center bridging task group. A converged Ethernet network is built based on the following DCB protocols:

- DCBX and ETS
- Priority Flow Control
- Fibre Channel over Ethernet (FCoE)
- iSCSI

DCBX and ETS

Existing Ethernet standards cannot control and manage the allocation of network bandwidth to different network traffic sources and types (traffic differentiation). Neither can existing standards allow prioritizing of bandwidth usage across these sources and traffic types. Data center managers must over-provision network bandwidth for peak loads, accept customer complaints during these periods, or manage traffic on the source side by limiting the amount of non-priority traffic entering the network.

Overcoming these limitations is a key to enabling Ethernet as the foundation for true converged data center networks supporting LAN, storage, and interprocessor communications.

Enhanced Transmission Selection (ETS) protocol addresses the bandwidth allocation issues among various traffic classes to maximize bandwidth usage. The IEEE 802.1Qaz standard specifies the protocol to support allocation of bandwidth among priority groups. ETS allows each node to control bandwidth per priority group. When the actual load in a priority group does not use its allocated bandwidth, ETS allows other priority groups to use the available bandwidth. The bandwidth-allocation priorities allow the sharing of bandwidth between traffic loads, while satisfying the strict priority mechanisms already defined in IEEE 802.1Q that require minimum latency.

Bandwidth allocation is achieved as part of a negotiation process with link peers—this is called DCB Capability eXchange protocol (DCBX). It provides a mechanism for Ethernet devices (bridges, end stations) to detect the DCB capability of a peer device. It also allows configuration and distribution of ETS parameters from one node to another.

ETS and DCBX simplify the management of DCB nodes significantly, especially when deployed end-to-end in a converged data center. The DCBX protocol uses Link Layer Discovery Protocol (LLDP) defined by IEEE 802.1AB to exchange and discover DCB capabilities.

Priority Flow Control

A fundamental requirement for a high performance storage network is guaranteed data delivery. This requirement must be satisfied to transport critical storage data on a converged Ethernet network with minimum latency. Another critical enhancement to conventional Ethernet is lossless Ethernet. IEEE 802.3X PAUSE defines how to pause link traffic at a congestion point to avoid packet drop. IEEE 802.1Qbb defines Priority Flow Control (PFC), which is based on IEEE 802.3X PAUSE and provides greater control of traffic flow. PFC eliminates lost frames caused by congestion. PFC enables the pausing of less sensitive data classes, while not affecting traditional LAN protocols operating through different priority classes.

Figure 4 shows how PFC works in a converged traffic scenario.

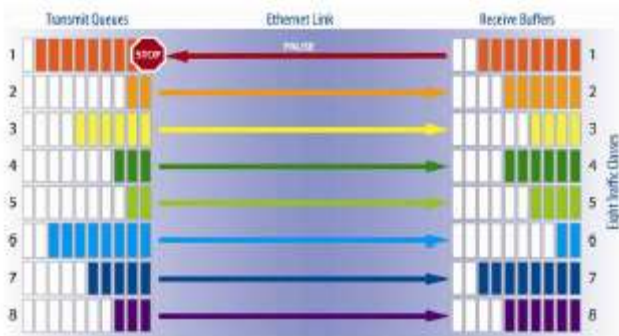

FIGURE 4 PRIORITY FLOW CONTROL

Fibre Channel over Ethernet (FCoE)

FCoE is an ANSI T11 standard for the encapsulation of a complete Fibre Channel frame into an Ethernet frame. The resulting Ethernet frame is transported over Enhanced Ethernet networks, as shown in Figure 5. Compared to other mapping technologies, FCoE has the least mapping overhead and maintains the same constructs as native Fibre Channel, thus operating with native Fibre Channel management software. FCoE is based on lossless Ethernet to enable buffer-to-buffer credit management and flow control of Fibre Channel packets.

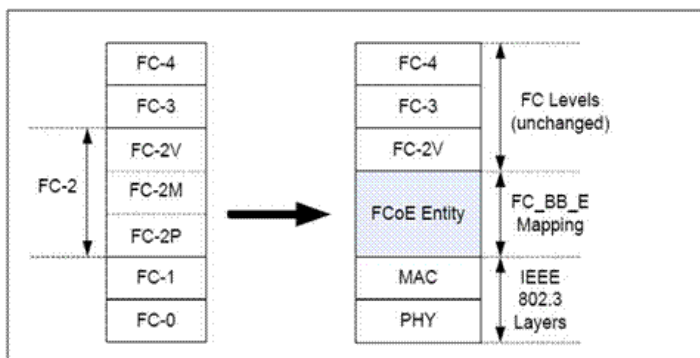

FIGURE 5 FCOE MAPPING ILLUSTRATION (SOURCE FC-BB-5 REV 2.0)

iSCSI

The Internet Small Computer Systems Interface (iSCSI) is a SCSI mass storage transport that operates between the Transport Control Protocol (TCP) and the SCSI Protocol Layers. The iSCSI protocol is defined in RFC 3720 [iSCSI], which was finalized by the Internet Engineering Task Force (IETF) in April 2004. A TCP/IP connection ties the iSCSI initiator and target session components together. Network portals identified by their IP address and TCP port numbers define the endpoints of a connection. iSCSI is, by nature, a lossless storage network because inherent in the iSCSI design is recovery from dropped packets on over-subscribed, heavy network traffic patterns. iSCSI relies on TCP/IP (or SCTP) for the retransmission of dropped Ethernet frames.

Appendix E: References

- *Unified Data Center Fabric Primer: FCoE and Data Center Bridging*, Martin, D. (2010). SearchNetworking.com, retrieved from http://searchnetworking.techtarget.com/tip/0,289483,sid7_gci1378613,00.html
- *Ethernet: The Converged Network Ethernet Alliance Demonstration at SC'09*, Ethernet Alliance. (2009), retrieved from http://www.ethernetalliance.org/files/static_page_files/281AD8C4-1D09-3519-AD7AD835AD525E36/SC09%20white%20paper.pdf
- *Unified Fabric: Data Center Bridging and FCoE Implementation*, Martin, D. (2010). SearchNetworking.com, retrieved from http://searchnetworking.techtarget.com/tip/0,289483,sid7_gci1379716_mem1,00.html?ShortReg=1&mboxConv=searchNetworking_RegActivate_Submit&



Deploying a Converged Network Using Oracle
CNAs and a Brocade FCoE Switch

September 2011

Author: Michael Wojnar

Oracle Corporation
World Headquarters
500 Oracle Parkway
Redwood Shores, CA 94065
U.S.A.

Worldwide Inquiries:
Phone: +1.650.506.7000
Fax: +1.650.506.7200

oracle.com



Oracle is committed to developing practices and products that help protect the environment

Copyright © 2011, Oracle and/or its affiliates. All rights reserved. This document is provided for information purposes only and the contents hereof are subject to change without notice. This document is not warranted to be error-free, nor subject to any other warranties or conditions, whether expressed orally or implied in law, including implied warranties and conditions of merchantability or fitness for a particular purpose. We specifically disclaim any liability with respect to this document and no contractual obligations are formed either directly or indirectly by this document. This document may not be reproduced or transmitted in any form or by any means, electronic or mechanical, for any purpose, without our prior written permission.

Oracle and Java are registered trademarks of Oracle and/or its affiliates. Other names may be trademarks of their respective owners.

Intel and Intel Xeon are trademarks or registered trademarks of Intel Corporation. All SPARC trademarks are used under license and are trademarks or registered trademarks of SPARC International, Inc. AMD, Opteron, the AMD logo, and the AMD Opteron logo are trademarks or registered trademarks of Advanced Micro Devices. UNIX is a registered trademark licensed through X/Open Company, Ltd. 0611

Hardware and Software, Engineered to Work Together