

ORACLE®

LINUX

FIPS 140-2 Non-Proprietary Security Policy

Oracle Linux OpenSSL Cryptographic Module

FIPS 140-2 Level 1 Validation

Software Versions: R6-1.0.0 and R7-2.0.0

Date: September 12th, 2017



Title: Oracle Linux OpenSSL Cryptographic Module Security Policy

Date: September 12th, 2017

Author: Atsec Information Security

Contributing Authors:

Oracle Linux Engineering

Oracle Security Evaluations – Global Product Security

Oracle Corporation

World Headquarters

500 Oracle Parkway

Redwood Shores, CA 94065

U.S.A.

Worldwide Inquiries:

Phone: +1.650.506.7000

Fax: +1.650.506.7200

oracle.com



Oracle is committed to developing practices and products that help protect the environment

Copyright © 2017, Oracle and/or its affiliates. All rights reserved. This document is provided for information purposes only and the contents hereof are subject to change without notice. This document is not warranted to be error-free, nor subject to any other warranties or conditions, whether expressed orally or implied in law, including implied warranties and conditions of merchantability or fitness for a particular purpose. Oracle specifically disclaim any liability with respect to this document and no contractual obligations are formed either directly or indirectly by this document. This document may reproduced or distributed whole and intact including this copyright notice.

Oracle and Java are registered trademarks of Oracle and/or its affiliates. Other names may be trademarks of their respective owners.

Hardware and Software, Engineered to Work Together



TABLE OF CONTENTS

Section	Title	Page
1. Introduction		1
1.1	Overview	1
1.2	Document Organization	2
2. Oracle Linux OpenSSL Cryptographic Module		3
2.1	Functional Overview	3
2.2	FIPS 140-2 Validation Scope	3
3. Cryptographic Module Specification		4
3.1	Definition of the Cryptographic Module	4
3.2	Definition of the Physical Cryptographic Boundary	5
3.3	Approved or Allowed Security Functions	6
3.4	Non-Approved But Allowed Security Functions	9
3.5	Non-Approved Security Functions	10
4. Module Ports and Interfaces		11
5. Physical Security		11
6. Operational Environment		12
6.1	Tested Environments	12
6.2	Vendor Affirmed Environments	12
6.3	Operational Environment Policy	16
7. Roles, Services and Authentication		17
7.1	Roles	17
7.2	FIPS Approved Operator Services and Descriptions	17
7.3	Non-FIPS Approved Services and Descriptions	18
7.4	Operator Authentication	19
8. Key and CSP Management		20
8.1	Random Number Generation	20
8.2	Key Generation	21
8.3	Key/CSP Storage	21
8.4	Key/CSP Zeroization	21
8.5	Key Establishment	21
9. Self-Tests		22
9.1	Power-Up Self-Tests	22
9.2	Conditional Self-Tests	22
9.3	On-Demand self-tests	23
10. Crypto-Officer and User Guidance		24
10.1	Crypto-Officer Guidance	24
10.2	User Guidance	25
10.2.1	TLS and Diffie-Hellman	25
10.2.2	Random Number Generator	25
10.2.3	AES GCM IV	25
10.2.4	Triple-DES Keys	25
10.3	Handling Self-Test Errors	25
11. Mitigation of Other Attacks		27
Acronyms, Terms and Abbreviations		28
References		29

List of Tables

Table 1: FIPS 140-2 Security Requirements	3
Table 2: FIPS Approved or Allowed Security Functions.....	9
Table 3: Non-Approved but Allowed Security Functions	10
Table 4: Non-Approved Disallowed Functions.....	10
Table 5: Mapping of FIPS 140 Logical Interfaces	11
Table 6: Tested Operating Environment.....	12
Table 7: Vendor Affirmed Operating Environment	20
Table 8: FIPS Approved Operator Services and Descriptions	22
Table 9: Non-FIPS Approved Operator Services and Descriptions.....	22
Table 10: CSP Table	24
Table 11: Power-On Self-Tests	26
Table 12: Conditional Self-Tests	27
Table 13: Acronyms.....	32
Table 14: References.....	33

List of Figures

Figure 1: Oracle Linux OpenSSL Logical Cryptographic Boundary	5
Figure 2: Oracle Linux OpenSSL Hardware Block Diagram	5

1. Introduction

1.1 Overview

Oracle Linux is a set of cryptographic libraries, services, and user level cryptographic applications that are validated at FIPS 140-2 level 1, providing a secure foundation for vendor use in developing dependent services, applications, and even purpose built appliances that may be FIPS 140-2 validated.

This section is informative to the reader to reference other cryptographic services of Oracle Linux. Only the software listed in section 3.1 is subject to the FIPS 140-2 validation. The CMVP makes no statement as to the correct operation of the module or the security strengths of the generated keys when supported if the specific operational environment is not listed on the validation certificate.

The FIPS 140-2 validation is performed at Security Level 1, on software only modules that do not make any claims about the hardware enclosure. This allows vendors to develop their own modules using these basic cryptographic modules and validate the new modules at a higher FIPS 140-2 security level.

The following cryptographic modules are included in Oracle Linux:

- OpenSSL– a software module supporting FIPS 140-2-approved cryptographic algorithms for general use by vendors
- OpenSSH-Server – supplies cryptographic support for the SSH protocol
- OpenSSH-Client – supplies cryptographic support for the SSH protocol
- NSS Cryptographic Module – supplies cryptographic support for TLS, PKCS #5, PKCS #7, PKCS #11 (version 2.20), PKCS #12, S/MIME, X.509 v3 certificates, and other security standards supporting FIPS 140-2 validated cryptographic algorithms
- Oracle Linux with the Unbreakable Enterprise Kernel – a software only cryptographic module that is an optimized kernel with a wide range of advanced features and improvements for enterprise workloads. It is the kernel installed and booted by default.
- Kernel Crypto API – a software only cryptographic module that provides general-purpose cryptographic services to the remainder of the Red Hat compatible Linux kernel
- Gnu TLS – general purpose cryptographic module to support TLS and DTLS network protocols
- Libgcrypt – supplies general cryptographic support for the Oracle Linux user space
- Libreswan (Oracle Linux 7 only) – provides the IKE protocol version 2 key agreement services required for IPsec
- Openswan (Oracle Linux 6 only) – provides the IKE protocol version 1 key agreement services required for IPsec implemented within Oracle’s Corente VPN

This Security Policy describes the features and design of the Oracle Linux OpenSSL Cryptographic Module using the terminology contained in the FIPS 140-2 specification. FIPS 140-2, Security Requirements for Cryptographic Module specifies the security requirements that will be satisfied by a cryptographic module utilized within a security system protecting sensitive but unclassified information. The NIST/CSE Cryptographic Module Validation Program (CMVP) validates cryptographic module to FIPS 140-2. Validated products are accepted by the Federal agencies of both the USA and Canada for the protection of sensitive or designated information.



1.2 Document Organization

The Security Policy document is one document in a FIPS 140-2 Submission Package. In addition to this document, the Submission Package contains:

- Oracle Linux OpenSSL Cryptographic Module Non-Proprietary Security Policy
- Other supporting documentation as additional references

With the exception of this Non-Proprietary Security Policy, the FIPS 140-2 Validation Documentation is proprietary to Oracle and is releasable only under appropriate non-disclosure agreements. For access to these documents, please contact Oracle.

2. Oracle Linux OpenSSL Cryptographic Module

2.1 Functional Overview

The Oracle Linux OpenSSL Cryptographic Module (hereafter referred to as the “Module”) is a software module supporting FIPS 140-2 Approved cryptographic algorithms within Oracle Linux. The code base of the Module is formed in a combination of standard OpenSSL shared Library, OpenSSL FIPS Object Module, and development work by Oracle Linux engineering. There are two versions of the module R6-1.0.0 running on Oracle Linux 6.9 and R7-2.0.0 running on Oracle Linux 7.3. The Oracle Linux OpenSSL Module is distributed with an open-source distribution. The Module provides a C language application program interface (API) for use by other processes that require cryptographic functionality.

Oracle Linux OpenSSL supports following three types of cryptographic implementations. The implementations available for an algorithm are listed in Table 2 and they can be selected based on the environment variable OPENSSL_ia32cap. Please refer to its man page for the details.

- a) OpenSSL in Native C Programming Language;
- b) AES-NI hardware acceleration for X86 processors;
- c) Assembler implementation.

2.2 FIPS 140-2 Validation Scope

The following table shows the security level for each of the eleven sections of the validation. See Table 1 below.

Security Requirements Section	Level
Cryptographic Module Specification	1
Cryptographic Module Ports and Interfaces	1
Roles and Services and Authentication	1
Finite State Machine Model	1
Physical Security	N/A
Operational Environment	1
Cryptographic Key Management	1
EMI/EMC	1
Self-Tests	1
Design Assurance	3
Mitigation of Other Attacks	1

Table 1: FIPS 140-2 Security Requirements

3. Cryptographic Module Specification

3.1 Definition of the Cryptographic Module

The Oracle Linux OpenSSL Module is defined as a multi-chip standalone module as defined by the requirements within FIPS PUB 140-2. The logical cryptographic boundary of the module consists of shared library files and their integrity check HMAC files, which are delivered through the Oracle Linux Yum Server as listed below:

The module version R7-2.0.0 running on Oracle Linux 7.3 has RPM file with version openssl-1.0.1e-60.0.1.el7_3.1.x86_64.rpm, which contains the following files:

- /usr/lib64/.libcrypto.so.1.0.1e.hmac (64 bits)
- /usr/lib64/.libssl.so.1.0.1e.hmac (64 bits)
- /usr/lib64/libcrypto.so.1.0.1e (64 bits)
- /usr/lib64/libssl.so.1.0.1e (64 bits)

The module instantiation is provided by the dracut-fips package with the version of the RPM file of dracut-fips-033-463.0.2.el7.x86_64.

The AES-NI configuration of kernel is provided by the Dracut-fips package with the version of the RPM file of dracut-fips-aesni-033-463.0.2.el7.x86_64

The module version R6-1.0.0 running on Oracle Linux 6.9 has RPM file with version openssl-1.0.1e-57.0.1.el6.x86_64.rpm, which contains the following files:

- /usr/lib64/.libcrypto.so.1.0.1e.hmac (64 bits)
- /usr/lib64/.libssl.so.1.0.1e.hmac (64 bits)
- /usr/lib64/libcrypto.so.1.0.1e (64 bits)
- /usr/lib64/libssl.so.1.0.1e (64 bits)

The module instantiation is provided by the dracut-fips package with the version of the RPM file of dracut-fips-004-409.0.3.el6_8.2.noarch.

The AES-NI configuration of the kernel is provided by the Dracut-fips package with the version of the RPM file of dracut-fips-aesni-004-409.0.3.el6_8.2.noarch

The Oracle OpenSSL package includes the binary files, integrity check HMAC files, Man Pages and the OpenSSL engines provided by the standard OpenSSL shared library. The OpenSSL engines and their shared object files are not part of the Module, and therefore they must not be used when operating the Module.

The Module shall be instantiated by the dracut-fips package with the RPM file version specified above. The dracut-fips RPM package is only used for the installation and instantiation of the Module. This code is not active when the Module is operational and does not provide any services to users interacting with the Module. Therefore the dracut-fips RPM package is outside the Modules' logical boundary.

Figure 1 shows the logical block diagram of the module executing in memory on the host system.

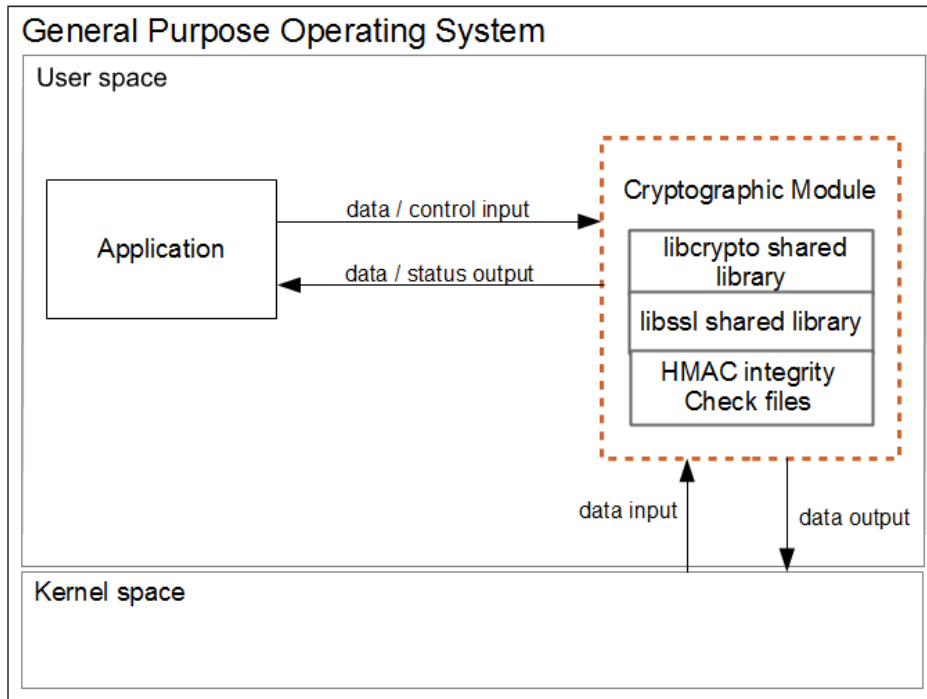

Figure 1: Oracle Linux OpenSSL Logical Cryptographic Boundary

3.2 Definition of the Physical Cryptographic Boundary

The physical cryptographic boundary of the module is defined as the hard enclosure of the host system on which it runs. See figure 2 below. No components are excluded from the requirements of FIPS PUB 140-2.

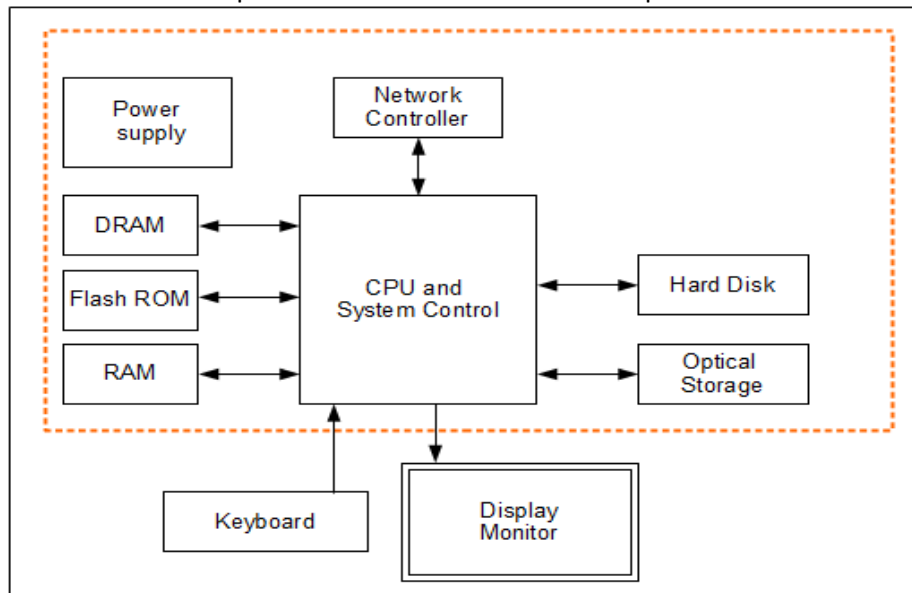

Figure 2: Oracle Linux OpenSSL Hardware Block Diagram

3.3 Approved or Allowed Security Functions

The Oracle Linux OpenSSL Cryptographic Module contains the following FIPS Approved Algorithms listed in Table 2. Certificate Numbers listed in column 'OL7' corresponds to module version R7-2.0.0 and the ones listed in column 'OL6' corresponds to module version R6-1.0.0.

Once the module is operational, the mode of operation is implicitly assumed depending on the services/security function invoked. By default the module enters Approved mode after the power-up tests succeed. In Approved mode, only approved or allowed security functions can be used as specified in table 2 and 3 and services listed in table 8.

Approved or Allowed Security Functions		OL7	OL6
Symmetric Algorithms			
AES	<p>AES-NI Implementation : ECB; CBC; CFB1;CFB8; CFB128; OFB (e/d; 128 , 192 , 256); CTR (int only; 128 , 192 , 256)</p> <p>CCM (KS: 128 , 192 , 256) (Assoc. Data Len Range: 0 - 0 , 2¹⁶) (Payload Length Range: 0 - 32 (Nonce Length(s): 7 8 9 10 11 12 13 (Tag Length(s): 4 6 8 10 12 14 16)</p> <p>CMAC (Generation/Verification) (KS: 128; Block Size(s): Full / Partial ; Msg Len(s) Min: 0 Max: 2¹⁶ ; Tag Len(s) Min: 0 Max: 16) (KS: 192; Block Size(s): Full / Partial ; Msg Len(s) Min: 0 Max: 2¹⁶ ; Tag Len(s) Min: 0 Max: 16) (KS: 256; Block Size(s): Full / Partial ; Msg Len(s) Min: 0 Max: 2¹⁶ ; Tag Len(s) Min: 0 Max: 16)</p> <p>GCM (KS: AES_128(e/d) Tag Length(s): 128 120 112 104 96 64 32) (KS: AES_192(e/d) Tag Length(s): 128 120 112 104 96 64 32) (KS: AES_256(e/d) Tag Length(s): 128 120 112 104 96 64 32) IV Generated: (Internal (using Section 8.2.1)) ; PT Lengths Tested: (0 , 128 , 1024 , 120 , 248) ; AAD Lengths tested: (0 , 128 , 1024 , 120 , 248) ; 96BitIV_Supported ; OtherIVLen_Supported GMAC_Supported KW (AE , AD , AES-128 , AES-192 , AES-256 , FWD , 128 , 256 , 192 , 320 , 4096) KWP¹ (AE , AD , AES-128 , AES-192 , 256 , FWD , 8 , 72 , 32 , 96 , 808)</p>	4538	4537
	<p>VPAES SSSE3 Implementation: ECB; CBC; CFB1;CFB8; CFB128; OFB (e/d; 128 , 192 , 256); CTR (int only; 128 , 192 , 256)</p> <p>CCM (KS: 128 , 192 , 256) (Assoc. Data Len Range: 0 - 0 , 2¹⁶) (Payload Length Range: 0 - 32 (Nonce Length(s): 7 8 9 10 11 12 13 (Tag Length(s): 4 6 8 10 12 14 16)</p> <p>CMAC (Generation/Verification) (KS: 128; Block Size(s): Full / Partial ; Msg Len(s) Min: 0 Max: 2¹⁶ ; Tag Len(s) Min: 0 Max: 16) (KS: 192; Block Size(s): Full / Partial ; Msg Len(s) Min: 0 Max: 2¹⁶ ; Tag Len(s) Min: 0 Max: 16) (KS: 256; Block Size(s): Full / Partial ; Msg Len(s) Min: 0 Max: 2¹⁶ ; Tag Len(s) Min: 0 Max: 16)</p> <p>GCM (KS: AES_128(e/d) Tag Length(s): 128 120 112 104 96 64 32) (KS: AES_192(e/d) Tag Length(s): 128 120 112 104 96 64 32) (KS: AES_256(e/d) Tag Length(s): 128 120 112 104 96 64 32)</p>	4534	4533

¹ KWP is only present on module version R7-2.0.0

Approved or Allowed Security Functions		OL7	OL6
	<p>IV Generated: (Internal (using Section 8.2.1)) ; PT Lengths Tested: (0 , 128 , 1024 , 120 , 248) ; AAD Lengths tested: (0 , 128 , 1024 , 120 , 248) ; 96BitIV_Supported ; OtherIVLen_Supported GMAC_Supported KW (AE , AD , AES-128 , AES-192 , AES-256 , FWD , 128 , 256 , 192 , 320 , 4096) KWP¹ (AE , AD , AES-128 , AES-192 , 256 , FWD , 8 , 72 , 32 , 96 , 808)</p>		
	<p><u>AES – Straight Assembler Implementation:</u> ECB; CBC; CFB1;CFB8; CFB128; OFB (e/d; 128 , 192 , 256) ; CTR (int only; 128 , 192 , 256)</p> <p>CCM (KS: 128 , 192 , 256) (Assoc. Data Len Range: 0 - 0 , 2¹⁶) (Payload Length Range: 0 - 32 (Nonce Length(s): 7 8 9 10 11 12 13 (Tag Length(s): 4 6 8 10 12 14 16)</p> <p>CMAC (Generation/Verification) (KS: 128; Block Size(s): Full / Partial ; Msg Len(s) Min: 0 Max: 2¹⁶ ; Tag Len(s) Min: 0 Max: 16) (KS: 192; Block Size(s): Full / Partial ; Msg Len(s) Min: 0 Max: 2¹⁶ ; Tag Len(s) Min: 0 Max: 16) (KS: 256; Block Size(s): Full / Partial ; Msg Len(s) Min: 0 Max: 2¹⁶ ; Tag Len(s) Min: 0 Max: 16)</p> <p>GCM (KS: AES_128(e/d) Tag Length(s): 128 120 112 104 96 64 32) (KS: AES_192(e/d) Tag Length(s): 128 120 112 104 96 64 32) (KS: AES_256(e/d) Tag Length(s): 128 120 112 104 96 64 32) IV Generated: (Internal (using Section 8.2.1)) ; PT Lengths Tested: (0 , 128 , 1024 , 120 , 248) ; AAD Lengths tested: (0 , 128 , 1024 , 120 , 248) ; 96BitIV_Supported ; OtherIVLen_Supported GMAC_Supported KW (AE , AD , AES-128 , AES-192 , AES-256 , FWD , 128 , 256 , 192 , 320 , 4096) KWP² (AE , AD , AES-128 , AES-192 , 256 , FWD , 8 , 72 , 32 , 96 , 808)</p>	4536	4535
Triple DES	<p><u>C Implementation:</u> TECB(KO 1 e/d ,) ; TCBC(KO 1 e/d ,) ; TCFB1(KO 1 e/d ,) ; TCFB8(KO 1 e/d ,) ; TCFB64(KO 1 e/d ,) ; TOFB(KO 1 e/d ,) ; CTR (int only CMAC (KS: 3-Key; Generation/Verification; Block Size(s): Full / Partial ; Msg Len(s) Min: 0 Max: 2¹⁶ ; Tag Len(s) Min: 0 Max: 8)</p>	2415	2414
Secure Hash Standard (SHS)			
SHS	<p><u>SHA1 AVX, SHA2 assembler Implementation:</u> SHA-1 (BYTE-only) SHA-224 (BYTE-only) SHA-256 (BYTE-only) SHA-384 (BYTE-only) SHA-512 (BYTE-only)</p>	3719	3718
	<p><u>Assembler Implementation:</u> SHA-1 (BYTE-only)</p>	3717	3716
	<p><u>SSSE3 Implementation:</u> SHA-1 (BYTE-only)</p>	3715	3714
Data Authentication Code			
HMAC	<u>using SHA1 AVX, SHA2 assembler Implementation:</u>	2996	2995

² KWP is only present on module version R7-2.0.0

Approved or Allowed Security Functions		OL7	OL6
	HMAC-SHA1 (Key Sizes Ranges Tested: KS<BS KS=BS KS>BS) HMAC-SHA224 (Key Size Ranges Tested: KS<BS KS=BS KS>BS) HMAC-SHA256 (Key Size Ranges Tested: KS<BS KS=BS KS>BS) HMAC-SHA384 (Key Size Ranges Tested: KS<BS KS=BS KS>BS) HMAC-SHA512 (Key Size Ranges Tested: KS<BS KS=BS KS>BS)		
	<u>Using SHA1 assembler Implementation:</u> HMAC-SHA1 (Key Size Ranges Tested: KS<BS KS=BS KS>BS)	2994	2993
	<u>using SHA1 SSSE3 Implementation:</u> HMAC-SHA1 (Key Size Ranges Tested: KS<BS KS=BS KS>BS)	2992	2991
Asymmetric Algorithms			
RSA2	<u>C Implementation:</u> FIPS186-2: ALG[ANSIX9.31]: SIG(gen); 4096 SHS: SHA-256, SHA-384, SHA-512 ALG[RSASSA-PKCS1_V1_5]: SIG(gen) 4096 , SHS: SHA-224Val, SHA-256, SHA-384 , SHA-512 ALG[RSASSA-PSS]: SIG(gen); 4096 , SHS: SHA-224 , SHA-256, SHA-384 , SHA-512 FIPS186-4: 186-4KEY(gen): FIPS186-4_Random_e PGM(ProbRandom: (2048 , 3072) PPTT:(C.2) ALG[ANSIX9.31] Sig(Gen): (2048 SHA(256 , 384 , 512)) (3072 SHA(256 , 384 , 512)) Sig(Ver): (1024 SHA(1 , 256 , 384 , 512)) (2048 SHA(1 , 256 , 384 , 512)) (3072 SHA(1 , 256 , 384 , 512)) ALG[RSASSA-PKCS1_V1_5] SIG(gen) (2048 SHA(224 , 256 , 384 , 512)) (3072 SHA(224 , 256 , 384 , 512)) SIG(Ver) (1024 SHA(1 , 224 , 256 , 384 , 512)) (2048 SHA(1 , 224 , 256 , 384 , 512)) (3072 SHA(1 , 224 , 256 , 384 , 512)) [RSASSA-PSS]: Sig(Gen): (2048 SHA(224 , 256 , 384 , 512)) (3072 SHA(224 , 256 , 384 , 512)) Sig(Ver): (1024 SHA(1 , 224 , 256 , 384 , 512)) (2048 SHA(1 , 224 , 256 , 384 , 512)) (3072 SHA(1 , 224 , 256 , 384 , 512))	2469	2468
DSA2	<u>C Implementation:</u> FIPS186-4: PQG(gen)PARMS TESTED: [(2048,224)SHA(224 , 256 , 384 , 512); (2048,256)SHA(256 , 384 , 512); (3072,256) SHA(256 , 384 , 512)] PQG(ver)PARMS TESTED: [(1024,160) SHA(1 , 224 , 256 , 384 , 512); (2048,224) SHA(224 , 256 , 384 , 512); (2048,256) SHA(256 , 384 , 512); (3072,256) SHA(256 , 384 , 512)] KeyPairGen: [(2048,224) ; (2048,256) ; (3072,256)] SIG(gen)PARMS TESTED: [(2048,224) SHA(224 , 256 , 384 , 512); (2048,256) SHA(224 , 256 , 384 , 512); (3072,256) SHA(224 , 256 , 384 , 512);] SIG(ver)PARMS TESTED: [(1024,160) SHA(1 , 224 , 256 , 384 , 512); (2048,224) SHA(1 , 224 , 256 , 384 , 512); (2048,256) SHA(1 , 224 , 256 , 384 , 512); (3072,256) SHA(1 , 224 , 256 , 384 , 512)]	1209	1208
ECDSA	<u>C Implementation:</u> FIPS186-4: PKG: CURVES(P-224 P-256 P-384 P-521 Testing Candidates) PKV: CURVES(P-224 P-256 P-384 P-521)	1105	1104

Approved or Allowed Security Functions		OL7	OL6
	<p>SigGen: CURVES(P-224: (SHA-224, 256, 384, 512) P-256: (SHA-224, 256, 384, 512) P-384: (SHA-224, 256, 384, 512) P-521: (SHA-224, 256, 384, 512)</p> <p>SigVer: CURVES(P-192: (SHA-1, 224, 256, 384, 512) P-224: (SHA-1, 224, 256, 384, 512) P-256: (SHA-1, 224, 256, 384, 512) P-384: (SHA-1, 224, 256, 384, 512) P-521: (SHA-1, 224, 256, 384, 512))</p>		
Random Number Generation			
DRBG	<p>C Implementation using AESNI, SHA1 AVX, SHA2 ASM:</p> <p>Hash_Based DRBG: Prediction Resistance Tested: Enabled and Not Enabled (SHA-1 , SHA-224 , SHA-256 , SHA-384 , SHA-512)</p> <p>HMAC_Based DRBG: Prediction Resistance Tested: Enabled and Not Enabled (SHA-1 , SHA-224 , SHA-256 , SHA-384 , SHA-512)</p> <p>CTR_DRBG: Prediction Resistance Tested: Enabled and Not Enabled; BlockCipher_Use_df: (AES-128 , AES-192 , AES-256) BlockCipher_No_df: (AES-128 , AES-192 , AES-256)</p>	1495	1494
	<p>Using AES and SHA1 assembler:</p> <p>Hash_Based DRBG: Prediction Resistance Tested: Enabled and Not Enabled (SHA-1)</p> <p>HMAC_Based DRBG: Prediction Resistance Tested: Enabled and Not Enabled (SHA-1)</p> <p>CTR_DRBG: Prediction Resistance Tested: Enabled and Not Enabled; BlockCipher_Use_df: (AES-128 , AES-192 , AES-256)</p> <p>BlockCipher_No_df: (AES-128 , AES-192 , AES-256)</p>	1493	1492
	<p>Using VPAES and SHA1 SSSE3:</p> <p>Hash_Based DRBG: Prediction Resistance Tested: Enabled and Not Enabled (SHA-1)</p> <p>HMAC_Based DRBG: Prediction Resistance Tested: Enabled and Not Enabled (SHA-1)</p> <p>CTR_DRBG: Prediction Resistance Tested: Enabled and Not Enabled; BlockCipher_Use_df: (AES-128 , AES-192 , AES-256)</p> <p>BlockCipher_No_df: (AES-128 , AES-192 , AES-256)</p>	1491	1490
Key Establishment (All of NIST SP 800-56A Except KDF)			
Diffie-Hellman	<p>C Implementation:</p> <p>FFC: (FUNCTIONS INCLUDED IN IMPLEMENTATION: DPG DPV KPG Key Regeneration)</p> <p>SCHEMES: Ephem: (KARole: Initiator / Responder) FB FC DSA</p>	CVL 1217	CVL 1216
EC Diffie-Hellman	<p>C Implementation:</p> <p>ECC: (FUNCTIONS INCLUDED IN IMPLEMENTATION: DPG DPV KPG Full Validation Key Regeneration)</p> <p>SCHEMES: EphemUnified: (KARole: Initiator / Responder) EB: P-224 EC: P-256 ED: P-384 EE: P-521</p>		
Key Derivation (NIST SP 800-135 Section 4.2 in TLS 1.0, 1.1, and 1.2)			
TLS	<p>C Implementation:</p> <p>(TLS1.0/1.1, TLS 1.2 (SHA 256, 384)</p>	CVL 1218	CVL 1215

Table 2: FIPS Approved or Allowed Security Functions

3.4 Non-Approved But Allowed Security Functions

The following are considered non-Approved but allowed security functions provided by the Module:

Algorithm	Usage
RSA Key Wrapping	Key wrapping, key establishment methodology provides between 112 and 256 bits of encryption strength, non-compliant less than 112 bits.
Diffie-Hellman	Key agreement, key establishment methodology provides between 112 and 256 bits of encryption strength, non-compliant less than 112 bits.
EC Diffie-Hellman	Key agreement, key establishment methodology provides between 112 and 256 bits of encryption strength, non-compliant less than 112 bits.
NDRNG	Used for seeding NIST SP 800-90A DRBG.
MD5	Message digest used in TLS only

Table 3: Non-Approved but Allowed Security Functions

3.5 Non-Approved Security Functions

Security functions listed in the table below, make use of non-approved cryptographic algorithms. Use of any of these algorithms and services in Table 9 will put the module in the non-Approved mode implicitly. The services associated with these algorithms are specified in section 7.2.

Algorithm	Usage
ANSI X9.31 RNG	Random Number Generation
AES XTS	Encryption/Decryption (CAVS tested but does not meet IG A.9)
Camellia	Encryption/Decryption
CAST	Encryption/Decryption
DES	Encryption/Decryption
Diffie-Hellman	Key agreement using keys less than 2048 bits
DSA	Parameter /Key generation/Signature generation with keys not listed in Table 2
EC Diffie-Hellman	Key agreement using NIST curve P-192
ECDSA	Key generation/Signature generation with NIST curve P-192
IDEA	Encryption/Decryption
J-PAKE	Password Authenticated Key Exchange
MD2	Hash Function
MD4	Hash Function
MDC2	Hash Function
RC2	Encryption/Decryption
RC4	Encryption/Decryption
RC5	Encryption/Decryption
RIPEMD	Hash Function
RSA	Key generation/Signature generation: keys less than 2048 bits
SHA-1	Signature generation
Whirlpool	Hash Function

Table 4: Non-Approved Disallowed Functions

4. Module Ports and Interfaces

The module interfaces can be categorized as follows:

- Data Input Interface
- Data Output Interface
- Control Input interface
- Status Output Interface

The module can be accessed by utilizing the API function it provides. Table 5 below, shows the mapping of interfaces as per FIPS 140-2 Standard.

FIPS 140 Interface	Module Interfaces
Data Input	API Input Parameters
Data Output	API Output Parameters
Control Input	API Function Calls
Status Output	API Return Values, error message

Table 5: Mapping of FIPS 140 Logical Interfaces

5. Physical Security

The Module is comprised of software only and thus does not claim any physical security.

6. Operational Environment

6.1 Tested Environments

The Modules were tested on the following environments with and without PAA i.e. AES-NI:

Module Version	Operating Environment	Processor	Hardware
R7-2.0.0	Oracle Linux 7.3 64 bit	Intel(R) Xeon(R) CPU E5-2699 v4	Oracle Server X6-2
R6-1.0.0	Oracle Linux 6.9 64 bit	Intel(R) Xeon(R) CPU E5-2699 v4	Oracle Server X6-2

Table 6: Tested Operating Environment

6.2 Vendor Affirmed Environments

The following platforms have not been tested as part of the FIPS 140-2 level 1 certification however Oracle “vendor affirms” that these platforms are equivalent to the tested and validated platforms. Additionally, Oracle affirms that the module will function the same way and provide the same security services on any of the systems listed below.

Operating Environment	Processor	Hardware
Oracle Linux 7.3 64-bit	Intel® Xeon® E5-2600/E5-2600 v2	Cisco UCS B200 M3
Oracle Linux 6.9 64-bit and Oracle Linux 7.3 64-bit	Intel® Xeon® E5-2600 v3 & v4	Cisco UCS B200 M4
Oracle Linux 7.3 64-bit	Intel® Xeon® E5-2400/E5-2400 v2	Cisco UCS B22 M3
Oracle Linux 7.3 64-bit	Intel® Xeon® E7-2800/E7-8800	Cisco UCS B230 M2
Oracle Linux 6.9 64-bit and Oracle Linux 7.3 64-bit	Intel® Xeon® E7-2800/E7-8800 v3	Cisco UCS B260 M4
Oracle Linux 6.9 64-bit and Oracle Linux 7.3 64-bit	Intel® Xeon® E5-4600/E5-4600 v2	Cisco UCS B420 M3
Oracle Linux 6.9 64-bit and Oracle Linux 7.3 64-bit	Intel® Xeon® E5-4600 v3 & v4	Cisco UCS B420 M4
Oracle Linux 7.3 64-bit	Intel® Xeon® E7-2800/E7-8800	Cisco UCS B440 M2
Oracle Linux 6.9 64-bit and Oracle Linux 7.3 64-bit	Intel® Xeon® E7-2800 v2/E7-4800 v2/E7-8800 v2/E7-4800 v3/E7-8800 v3	Cisco UCS B460 M4
Oracle Linux 6.9 64-bit and Oracle Linux 7.3 64-bit	Intel® Xeon® E5-2400/E5-2400 v2	Cisco UCS C22 M3
Oracle Linux 6.9 64-bit and Oracle Linux 7.3 64-bit	Intel® Xeon® E5-2600/E5-2600 v2	Cisco UCS C220 M3
Oracle Linux 6.9 64-bit and Oracle Linux 7.3 64-bit	Intel® Xeon® E5-2600 v3 & v4	Cisco UCS C220 M4
Oracle Linux 6.9 64-bit and Oracle Linux 7.3 64-bit	Intel® Xeon® E5-2400/E5-2400 v2	Cisco UCS C24 M3
Oracle Linux 6.9 64-bit and Oracle Linux 7.3 64-bit	Intel® Xeon® E5-2600/E5-2600 v2	Cisco UCS C240 M3
Oracle Linux 6.9 64-bit and Oracle Linux 7.3 64-bit	Intel® Xeon® E5-2600 v3 & v4	Cisco UCS C240 M4
Oracle Linux 6.9 64-bit and Oracle Linux 7.3 64-bit	Intel® Xeon® E7-2800 v2/E7-4800 v2, v3 & v4/E7-8800 v2 & v4	Cisco UCS C460 M4
Oracle Linux 6.9 64-bit and Oracle Linux 7.3 64-bit	Intel® Xeon® E5-2600 v3	Dell PowerEdge FC630
Oracle Linux 6.9 64-bit and Oracle Linux 7.3 64-bit	Intel® Xeon® E5-4600 v3	Dell PowerEdge FC830
Oracle Linux 6.9 64-bit and Oracle Linux 7.3 64-bit	Intel® Xeon® E5-2600 v3	Dell PowerEdge M630 Blade
Oracle Linux 6.9 64-bit and Oracle Linux 7.3 64-bit	Intel® Xeon® E5-4600 v4	Dell PowerEdge M830 Blade
Oracle Linux 6.9 64-bit and Oracle Linux 7.3 64-bit	Intel® Xeon® E5-2600 v3	Dell PowerEdge R630



Operating Environment	Processor	Hardware
Oracle Linux 6.9 64-bit and Oracle Linux 7.3 64-bit	Intel® Xeon® E5-2600 v3	Dell PowerEdge R730
Oracle Linux 6.9 64-bit and Oracle Linux 7.3 64-bit	Intel® Xeon® E5-2600 v3	Dell PowerEdge R730xd
Oracle Linux 6.9 64-bit and Oracle Linux 7.3 64-bit	Intel® Xeon® E7-4800 v4	Dell PowerEdge R930
Oracle Linux 6.9 64-bit and Oracle Linux 7.3 64-bit	Intel® Xeon® E5-2600 v3	Dell PowerEdge T630
Oracle Linux 6.9 64-bit and Oracle Linux 7.3 64-bit	Intel® Xeon® E7-4800 v2/E7-8800 v2	Fujitsu PRIMEQUEST 2400E
Oracle Linux 6.9 64-bit and Oracle Linux 7.3 64-bit	Intel® Xeon® E7-8800 v3	Fujitsu PRIMEQUEST 2400E2
Oracle Linux 6.9 64-bit and Oracle Linux 7.3 64-bit	Intel® Xeon® E7-8800 v4	Fujitsu PRIMEQUEST 2400E3
Oracle Linux 6.9 64-bit and Oracle Linux 7.3 64-bit	Intel® Xeon® E7-4800 v2	Fujitsu PRIMEQUEST2400L
Oracle Linux 6.9 64-bit and Oracle Linux 7.3 64-bit	Intel® Xeon® E7-8800 v3	Fujitsu PRIMEQUEST2400L2
Oracle Linux 6.9 64-bit and Oracle Linux 7.3 64-bit	Intel® Xeon® E7-8800 v4	Fujitsu PRIMEQUEST 2400L3
Oracle Linux 6.9 64-bit and Oracle Linux 7.3 64-bit	Intel® Xeon® E7-4800 v2	Fujitsu PRIMEQUEST 2400S
Oracle Linux 6.9 64-bit and Oracle Linux 7.3 64-bit	Intel® Xeon® E7-4800 v2	Fujitsu PRIMEQUEST 2400S Lite
Oracle Linux 6.9 64-bit and Oracle Linux 7.3 64-bit	Intel® Xeon® E7-8800 v3	Fujitsu PRIMEQUEST 2400S2
Oracle Linux 6.9 64-bit and Oracle Linux 7.3 64-bit	Intel® Xeon® E7-8800 v3	Fujitsu PRIMEQUEST 2400S2 Lite
Oracle Linux 6.9 64-bit and Oracle Linux 7.3 64-bit	Intel® Xeon® E7-8800 v4	Fujitsu PRIMEQUEST 2400S3
Oracle Linux 6.9 64-bit and Oracle Linux 7.3 64-bit	Intel® Xeon® E7-8800 v4	Fujitsu PRIMEQUEST 2400S3 Lite
Oracle Linux 6.9 64-bit and Oracle Linux 7.3 64-bit	Intel® Xeon® E7-8800 v2	Fujitsu PRIMEQUEST 2800B
Oracle Linux 6.9 64-bit and Oracle Linux 7.3 64-bit	Intel® Xeon® E7-8800 v3	Fujitsu PRIMEQUEST 2800B2
Oracle Linux 6.9 64-bit and Oracle Linux 7.3 64-bit	Intel® Xeon® E7-8800 v4	Fujitsu PRIMEQUEST 2800B3
Oracle Linux 6.9 64-bit and Oracle Linux 7.3 64-bit	Intel® Xeon® E7-8800 v2	Fujitsu PRIMEQUEST 2800E
Oracle Linux 6.9 64-bit and Oracle Linux 7.3 64-bit	Intel® Xeon® E7-8800 v3	Fujitsu PRIMEQUEST 2800E2
Oracle Linux 6.9 64-bit and Oracle Linux 7.3 64-bit	Intel® Xeon® E7-8800 v4	Fujitsu PRIMEQUEST 2800E3
Oracle Linux 6.9 64-bit and Oracle Linux 7.3 64-bit	Intel® Xeon® E7-8800 v2	Fujitsu PRIMEQUEST 2800L
Oracle Linux 6.9 64-bit and Oracle Linux 7.3 64-bit	Intel® Xeon® E7-8800 v3	Fujitsu PRIMEQUEST 2800L2
Oracle Linux 6.9 64-bit and Oracle Linux 7.3 64-bit	Intel® Xeon® E7-8800 v4	Fujitsu PRIMEQUEST 2800L3
Oracle Linux 6.9 64-bit and Oracle Linux 7.3 64-bit	Intel® Xeon® E5-2600 v3	Fujitsu PRIMERGY BX2580 M1
Oracle Linux 6.9 64-bit and Oracle Linux 7.3 64-bit	Intel® Xeon® E5-2600 v4	Fujitsu PRIMERGY BX2580 M2
Oracle Linux 6.9 64-bit and Oracle Linux 7.3 64-bit	Intel® Xeon® E5-2600 v3	Fujitsu PRIMERGY RX2530 M1
Oracle Linux 6.9 64-bit and Oracle Linux 7.3 64-bit	Intel® Xeon® E5-2600 v4	Fujitsu PRIMERGY RX2530 M2
Oracle Linux 6.9 64-bit and Oracle Linux 7.3 64-bit	Intel® Xeon® E5-2600 v3	Fujitsu PRIMERGY RX2540 M1
Oracle Linux 6.9 64-bit and Oracle Linux 7.3 64-bit	Intel® Xeon® E5-2600 v4	Fujitsu PRIMERGY RX2540 M2
Oracle Linux 7.3 64-bit	Intel® Xeon® E7-4800 v2/E7-8800 v2	Fujitsu PRIMERGY RX4770 M1
Oracle Linux 6.9 64-bit and Oracle Linux 7.3 64-bit	Intel® Xeon® E7-4800 v3/E7-8800 v3	Fujitsu PRIMERGY RX4770 M2
Oracle Linux 6.9 64-bit and Oracle Linux 7.3 64-bit	Intel® Xeon® E7-4800 v4/E7-8800 v4	Fujitsu PRIMERGY RX4770 M3
Oracle Linux 6.9 64-bit	Intel® Xeon® E5-2600 v3	Hitachi BladeSymphony BS2500 HCOA1
Oracle Linux 6.9 64-bit	Intel® Xeon® E5-2600 v4	Hitachi BladeSymphony BS2500 HE0A2
Oracle Linux 6.9 64-bit	Intel® Xeon® E7-4800 v3/E7-8800 v3	Hitachi BladeSymphony BS2500 HE0E2
Oracle Linux 6.9 64-bit	Intel® Xeon® E5-2600 v3	Hitachi BladeSymphony BS500 BS520H B3
Oracle Linux 6.9 64-bit	Intel® Xeon® E7-4800 v3/E7-8800 v3	Hitachi BladeSymphony BS500 BS520X B2

Operating Environment	Processor	Hardware
Oracle Linux 6.9 64-bit	Intel® Xeon® E5-2600 v3	Hitachi Compute Blade 2500 CB520H B3
Oracle Linux 6.9 64-bit and Oracle Linux 7.3 64-bit	Intel® Xeon® E5-2600 v4	Hitachi Compute Blade 2500 CB520H B4
Oracle Linux 6.9 64-bit and Oracle Linux 7.3 64-bit	Intel® Xeon® E7-8800 v2	Hitachi Compute Blade 2500 CB520X B2
Oracle Linux 6.9 64-bit and Oracle Linux 7.3 64-bit	Intel® Xeon® E7-8800 v3	Hitachi Compute Blade 2500 CB520X B3
Oracle Linux 6.9 64-bit	Intel® Xeon® E5-2600 v3	Hitachi Compute Blade 500 CB520H B3
Oracle Linux 7.3 64-bit	Intel® Xeon® E5-2600 v4	Hitachi Compute Blade 500 CB520H B4
Oracle Linux 6.9 64-bit and Oracle Linux 7.3 64-bit	Intel® Xeon® E7-8800 v2	Hitachi Compute Blade 500 CB520X B2
Oracle Linux 6.9 64-bit	Intel® Xeon® E5-2600 v4	Hitachi HA8000 RS210 AN2
Oracle Linux 6.9 64-bit	Intel® Xeon® E5-2600 v4	Hitachi HA8000 RS220 AN2
Oracle Linux 6.9 64-bit and Oracle Linux 7.3 64-bit	Intel® Xeon® E5-2600 v4	Hitachi QuantaGrid D51B-2U
Oracle Linux 6.9 64-bit and Oracle Linux 7.3 64-bit	Intel® Xeon® E5-2600 v3 & v4	Hitachi QuantaPlex T41S-2U
Oracle Linux 7.3 64-bit	Intel® Xeon® E7-4800 v4/E7-8800 v4	HPE Integrity MC990 X
Oracle Linux 6.9 64-bit and Oracle Linux 7.3 64-bit	Intel® Xeon® E5-2600 v2	HPE ProLiant BL460c Gen8
Oracle Linux 6.9 64-bit and Oracle Linux 7.3 64-bit	Intel® Xeon® E5-2600 v3	HPE ProLiant BL460c Gen9
Oracle Linux 6.9 64-bit	AMD Opteron 6300-series	HPE ProLiant BL465c Gen8
Oracle Linux 6.9 64-bit	Intel® Xeon® E5-4600 v2	HPE ProLiant BL660c Gen8
Oracle Linux 6.9 64-bit and Oracle Linux 7.3 64-bit	Intel® Xeon® E5-4600 v3	HPE ProLiant BL660c Gen9
Oracle Linux 6.9 64-bit	Intel® Xeon® E5-2600 v3 & v4	HPE ProLiant DL120 Gen9
Oracle Linux 7.3 64-bit	Intel® Xeon® E5-2600 v3 & v4	HPE ProLiant DL160 Gen9
Oracle Linux 6.9 64-bit and Oracle Linux 7.3 64-bit	Intel® Xeon® E5-2600 v3 & v4	HPE ProLiant DL180 Gen9
Oracle Linux 6.9 64-bit and Oracle Linux 7.3 64-bit	Intel® Pentium® G2120 & Intel® Xeon® E3-1200 v2	HPE ProLiant DL320e Gen8
Oracle Linux 6.9 64-bit and Oracle Linux 7.3 64-bit	Intel® Pentium® G3200-series/G3420, Core i3-4100-series/Intel® Xeon® E3-12 v3	HPE ProLiant DL320e Gen8 v2
Oracle Linux 6.9 64-bit and Oracle Linux 7.3 64-bit	Intel® Xeon® E5-2600 v3 & v4	HPE ProLiant DL360 Gen9
Oracle Linux 6.9 64-bit and Oracle Linux 7.3 64-bit	Intel® Xeon® E5-2400/E5-2400 v2	HPE ProLiant DL360e Gen8
Oracle Linux 6.9 64-bit and Oracle Linux 7.3 64-bit	Intel® Xeon® E5-2600 v3 & v4	HPE ProLiant DL360p Gen8
Oracle Linux 6.9 64-bit and Oracle Linux 7.3 64-bit	Intel® Xeon® E5-2600 v3 & v4	HPE ProLiant DL380 Gen9
Oracle Linux 6.9 64-bit and Oracle Linux 7.3 64-bit	Intel® Xeon® E5-2400/E5-2400 v2	HPE ProLiant DL380e Gen8
Oracle Linux 6.9 64-bit	Intel® Xeon® E5-2600/E5-2600 v2	HPE ProLiant DL380p Gen8
Oracle Linux 7.3 64-bit	Intel® Xeon® E5-4600/E5-4600 v2	HPE ProLiant DL560 Gen8
Oracle Linux 6.9 64-bit and Oracle Linux 7.3 64-bit	Intel® Xeon® E5-4600 v3 & v4	HPE ProLiant DL560 Gen9
Oracle Linux 6.9 64-bit and Oracle Linux 7.3 64-bit	Intel® Xeon® E7-4800 v2/E7-8800 v2	HPE ProLiant DL580 Gen8
Oracle Linux 6.9 64-bit and Oracle Linux 7.3 64-bit	Intel® Xeon® E7-4800 v3/E7-8800 v3	HPE ProLiant DL580 Gen9
Oracle Linux 6.9 64-bit	Intel® Xeon® X7560, X6550, E6540, E7520	HPE ProLiant DL980 G7
Oracle Linux 6.9 64-bit and Oracle Linux 7.3 64-bit	Intel® Xeon® E5-2600 v3 & v4	HPE ProLiant ML350 Gen9



Operating Environment	Processor	Hardware
Oracle Linux 6.9 64-bit	Intel® Xeon® E5-2600 v3	HPE ProLiant XL450 Gen9 (Apollo 4500)
Oracle Linux 6.9 64-bit and Oracle Linux 7.3 64-bit	Intel® Xeon® E5-2600 v4	HPE Synergy 480 Gen9 Compute Module
Oracle Linux 6.9 64-bit and Oracle Linux 7.3 64-bit	Intel® Xeon® E7-4800 v4/E7-8800 v4	HPE Synergy 620 Gen9 Compute Module
Oracle Linux 6.9 64-bit and Oracle Linux 7.3 64-bit	Intel® Xeon® E7-4800 v4/E7-8800 v4	HPE Synergy 680 Gen9 Compute Module
Oracle Linux 6.9 64-bit and Oracle Linux 7.3 64-bit	Intel® Xeon® E5-2600 v3	Inspur Yingxin NF5180M4
Oracle Linux 6.9 64-bit	Intel® Xeon® E5-2600 v3 & v4	Inspur Yingxin NF5240M4
Oracle Linux 6.9 64-bit	Intel® Xeon® E5-2600 v2	Inspur Yingxin NF5270M3
Oracle Linux 6.9 64-bit and Oracle Linux 7.3 64-bit	Intel® Xeon® E5-2600 v3 & v4	Inspur Yingxin NF5280M4
Oracle Linux 6.9 64-bit and Oracle Linux 7.3 64-bit	Intel® Xeon® E7-4800 v3 & v4/E7-8800 v3 & v4	Inspur Yingxin NX8480M4
Oracle Linux 6.9 64-bit	Intel® Xeon® E5-2600 v4	Lenovo System x3650 M5
Oracle Linux 6.9 64-bit	Intel® Xeon® E7-4800 v4/E7-8800 v4	Lenovo System x3850 X6
Oracle Linux 7.3 64-bit	Intel® Xeon® E7-4800 v4/E7-8800 v4	NEC Express 5800/A1040d
Oracle Linux 7.3 64-bit	Intel® Xeon® E7-4800 v4/E7-8800 v4	NEC Express 5800/A2010d
Oracle Linux 7.3 64-bit	Intel® Xeon® E7-4800 v4/E7-8800 v4	NEC Express 5800/A2020d
Oracle Linux 7.3 64-bit	Intel® Xeon® E7-4800 v4/E7-8800 v4	NEC Express 5800/A2040d
Oracle Linux 6.9 64-bit	Intel® Xeon® E5-4800 v4/E7-8800 v4	NEC Express 5800/R120g-1M
Oracle Linux 6.9 64-bit	Intel® Xeon® E5-2600 v4	NEC Express 5800/R120g-2M
Oracle Linux 7.3 64-bit	Intel® Xeon® E7-4800 v4/E7-8800 v4	NEC NX7700x/A4010M-4
Oracle Linux 7.3 64-bit	Intel® Xeon® E7-4800 v4/E7-8800 v4	NEC NX7700x/A4012L-1
Oracle Linux 7.3 64-bit	Intel® Xeon® E7-4800 v4/E7-8800 v4	NEC NX7700x/A4012L-2
Oracle Linux 7.3 64-bit	Intel® Xeon® E7-4800 v3/E7-8800 v3	NEC NX7700x/A4012M-4
Oracle Linux 6.9 64-bit and Oracle Linux 7.3 64-bit	Intel® Xeon® E5-2600 v3	Oracle Netra Server X5-2
Oracle Linux 6.9 64-bit and Oracle Linux 7.3 64-bit	Intel® Xeon® E5-2600 v3	Oracle Server X5-2
Oracle Linux 7.3 64-bit	Intel® Xeon® E5-2600 v3	Oracle Server X5-2L
Oracle Linux 7.3 64-bit	Intel® Xeon® E7-8800 v3	Oracle Server X5-4
Oracle Linux 7.3 64-bit	Intel® Xeon® E7-8800 v3	Oracle Server X5-8
Oracle Linux 6.9 64-bit and Oracle Linux 7.3 64-bit	Intel® Xeon® E5-2600 v4	Oracle Server X6-2L
Oracle Linux 6.9 64-bit and Oracle Linux 7.3 64-bit	Intel® Xeon® E5-2600 v4	Oracle Server X6-2M
Oracle Linux 7.3 64-bit	Intel® Xeon® x7500-series	Oracle Sun Fire X4470
Oracle Linux 7.3 64-bit	Intel® Xeon® x7500-series	Oracle Sun Fire X4800
Oracle Linux 7.3 64-bit	Intel® Xeon® E7-8800	Oracle Sun Server X2-8
Oracle Linux 7.3 64-bit	Intel® Xeon® E7-4800	Oracle Sun Server X2-4
Oracle Linux 6.9 64-bit and Oracle Linux 7.3 64-bit	Intel® Xeon® E5-2600	Oracle Sun Server X3-2
Oracle Linux 6.9 64-bit and Oracle Linux 7.3 64-bit	Intel® Xeon® E5-2600	Oracle Sun Server X3-2L
Oracle Linux 6.9 64-bit and Oracle Linux 7.3 64-bit	Intel® Xeon® E5-2600 v2	Oracle Sun Server X4-2
Oracle Linux 6.9 64-bit and Oracle Linux 7.3 64-bit	Intel® Xeon® E5-2600 v2	Oracle Sun Server X4-2L
Oracle Linux 7.3 64-bit	Intel® Xeon® E7-8800 v2	Oracle Sun Server X4-4
Oracle Linux 7.3 64-bit	Intel® Xeon® E7-8800 v2	Oracle Sun Server X4-8
Oracle Linux 7.3 64-bit	Intel® Xeon® E7-8800 v3 & v4	SGI UV 300RL

Operating Environment	Processor	Hardware
Oracle Linux 7.3 64-bit	Intel® Xeon® E7-4800 v4/ E7-8800 v3 & v4	SGI UV 300
Oracle Linux 7.3 64-bit	AMD Opteron™ 6000	Sugon CB85-G10
Oracle Linux 7.3 64-bit	Intel® Xeon® E5-2600 v3 & v4	Sugon CB85-G10
Oracle Linux 7.3 64-bit	Intel® Xeon® E7-4800 v2	Sugon CB80-G20
Oracle Linux 7.3 64-bit	Intel® Xeon® E7-4800 v4	Sugon CB85-G10
Oracle Linux 7.3 64-bit	AMD Opteron™ 6300	Sugon CB85-G10
Oracle Linux 7.3 64-bit	Intel® Xeon® E5-2600 v3	Sugon I610-G20
Oracle Linux 7.3 64-bit	Intel® Xeon® E5-2600 v3	Sugon I620-G20
Oracle Linux 7.3 64-bit	Intel® Xeon® E7-4800 v3 & v4	Sugon I840-G20
Oracle Linux 7.3 64-bit	Intel® Xeon® E7-4800 v2	Sugon I840-G25
Oracle Linux 7.3 64-bit	Intel® Xeon® E7-4800 v2 & v3/E7-8800 v2 & v3	Sugon I980-G20
Oracle Linux 7.3 64-bit	Intel® Xeon® E5-2600 v3 & v4	Sugon TC4600T

Table 7: Vendor Affirmed Operating Environment

CMVP makes no statement as to the correct operation of the module or the security strengths of the generated keys when so ported if the specific operational environment is not listed on the validation certificate.

6.3 Operational Environment Policy

The operating system is restricted to a single operator mode of operation (i.e., concurrent operators are explicitly excluded).

The application that makes calls to the Modules is the single user of the Modules, even when the application is serving multiple clients.

During module operation, the ptrace(2) system call, the debugger (gdb(1)), and strace(1) shall not be used. In addition, other tracing mechanisms offered by the Linux environment, such as Dtrace, ftrace or systemtap, shall not be used.



7. Roles, Services and Authentication

7.1 Roles

The Oracle Linux OpenSSL Cryptographic Module supports 2 roles as required by FIPS PUB 140-2. These roles are a Crypto Officer Role and a User Role. Both roles are implicitly assumed by the entity accessing services implemented by the Module. The module does not support authentication mechanisms.

7.2 FIPS Approved Operator Services and Descriptions

The below table provides a full description of FIPS Approved services provided by the module and lists the roles allowed to invoke each service. In the table below, the “U” represents a User Role, and “CO” denotes a Crypto Officer role.

U	CO	Service Name	Service Description	Keys and CSP(s)	Access Type(s)
X		Symmetric Encryption/Decryption	Encrypts or decrypts a block of data using 3-Key Triple-DES or AES	AES or 3-Key Triple-DES Key	R, W, X
X		Asymmetric Key Generation	Generate RSA, DSA/ Diffie-Hellman, ECDSA/ EC Diffie-Hellman asymmetric keys	RSA, DSA/ Diffie-Hellman, ECDSA/EC Diffie-Hellman keys	R, W, X
X		Digital Signature Generation and Verification	Sign and verify operations	RSA, DSA, and ECDSA keys	R, W, X
X		TLS Network Protocol	Provide data encryption and authentication over TLS network protocol	AES, Triple-DES, and HMAC keys.	R, W, X
X		TLS Key Agreement	Negotiate a TLS key agreement secure channel	AES or Triple-DES key, RSA, DSA or ECDSA private key, HMAC Key, shared secret, Diffie-Hellman and EC Diffie-Hellman Private keys	R, W, X
X		Asymmetric Encryption/Decryption	Encrypts or decrypts using Approved RSA key size	RSA key pair	R, W, X
X		Certificate Management Handling	Management of key properties within certificates.	RSA, DSA, and ECDSA private keys	R, W, X
X		Keyed Hash (HMAC)	Sign and or authenticate data using HMAC-SHA	HMAC Key	R, W, X
X		Keyed Hash (CMAC)	Encrypt and sign data using CMAC.	AES or 3-Key Triple-DES Key	R, W, X
X		Hash (SHS)	Hash a block of data.	None	R, W, X
X		Random Number Generation	Generate random numbers based on the NIST SP 800-90A Standard	Entropy input string and internal State	R, W, X
X		Show Status	Show status of the module state	None	X

U	CO	Service Name	Service Description	Keys and CSP(s)	Access Type(s)
X		Self-Test	Initiate power-on self-tests	None	R, X
X		Zeroize	Zeroize all critical security parameters	All keys and CSP's	Z
	X	Module Installation	Installation of the module	None	R, W

R – Read, W – Write, X – Execute, Z - Zeroize

Table 8: FIPS Approved Services and Descriptions

7.3 Non-FIPS Approved Services and Descriptions

The following table lists the non-Approved services available in non-FIPS mode.

U	CO	Service Name	Service Description	Keys and CSP(s)	Access Type(s)
X		Asymmetric Encryption/Decryption	Encrypts or decrypts using non-Approved RSA key size	RSA key pair	R, W, X
X		Symmetric Encryption/Decryption	Encrypts or decrypts using non-Approved algorithms	AES XTS, Camellia, CAST, DES, IDEA, RC2, RC4, RC5 keys	R, W, X
X		Digital Signature Generation and Verification	Sign or verify operations with non-Approved RSA or DSA key lengths	RSA key < 2048 DSA keys not listed in Table 2 Signature Generation with SHA-1	R, W, X
X		TLS Key Agreement	Negotiate a TLS key agreement secure channel with non-Approved key sizes	RSA/ Diffie-Hellman key < 2048 EC Diffie-Hellman with P-192	R, W, X
X		Asymmetric Key Generation	Generation of non-Approved RSA and DSA keys	RSA key < 2048 DSA keys not listed in Table 2	R, W, X
X		Random Number Generation	Generation of random numbers using the ANSI X9.31 PRNG	seed, seed key	R, W, X
X		Hash	Hashing using non-Approved hash functions that include MD2, MD4, MD5, MDC2, RIPEMD, Whirlpool	None	R, W, X
X		J-PAKE Key Agreement	Password authenticated key agreement using J-PAKE	J-PAKE key pair	R, W, X

Table 9: Non-FIPS Approved Services and Descriptions



7.4 Operator Authentication

The module does not support operator authentication mechanisms.

8. Key and CSP Management

The following keys, cryptographic key components and other critical security parameters are contained in the module.

CSP Name	Generation/Input	Use
AES Key (128, 192, 256 bits)	The Key is passed into the module via API input parameter	Encrypt/Decrypt operations Used to generate and verify MAC's with AES as part of the CMAC algorithm.
Triple-DES Keys (192 bits)		Used for Encrypt/Decrypt operations. Used for generating and verifying MAC's with Triple-DES as part of the CMAC algorithm.
HMAC Key (≥ 112 bits)		HMAC keys used to generate and verify MAC's on data.
RSA Key pair (2048, 3072, 4096 bits)	Keys are generated using FIPS 186-4 and the random value used in the key generation is generated using SP800-90A DRBG	RSA public/private keys used to sign and verify data. RSA private key used for key decryption as part of key wrapping.
DSA/ Diffie-Hellman Key pair (2048 , 3072, 4096 bits)		DSA public/private keys used to sign and verify data. Diffie-Hellman key pair used as part of the key agreement protocol.
ECDSA/ EC Diffie-Hellman Key pair (P-224,P-256, P-384, P-521)		ECDSA public/private keys used to sign and verify data. EC Diffie-Hellman key pair used as part of the key agreement protocol.
Shared secret	Generated during the Diffie-Hellman or EC Diffie-Hellman key agreement.	Used to derive the required keys by applying key derivation function.
Entropy input string	Obtained from NDRNG	Entropy input strings used as part of the DRBG process.
DRBG Internal stated (V,C , Key value)	During DRBG initialization.	V and key are used as part of HMAC and CTR DRBG process. V and C are used as part of HASH DRBG process.

Table 10: CSP Table

8.1 Random Number Generation

The Module provides an SP800-90A-compliant DRBG for the creation of key components of asymmetric keys, and random number generation.

The Module uses NDRNG from /dev/urandom as a source of entropy for seeding the DRBG. The NDRNG is provided by the operational environment (i.e., Linux RNG), which is within the module's physical boundary but outside of the module's logical boundary. The NDRNG provides at least 130 bits of entropy to the DRBG.

The module generates cryptographic keys whose strengths are modified by available entropy.

The Module performs continuous random number generator test (CRNGT) on the output of SP800-90A DRBG to ensure that consecutive random numbers do not repeat. The underlying operating system performs the continuous test on the NDRNG.

8.2 Key Generation

For generating RSA, DSA/DH and ECDSA/ECDH keys, the module implements asymmetric key generation services compliant with [FIPS186-4], and using DRBG compliant with [SP800-90A]. A seed (i.e. the random value) used in asymmetric key generation is obtained from [SP800-90A] DRBG. The module does not implement symmetric key generation. In accordance with FIPS 140-2 IG D.12, the cryptographic module performs Cryptographic Key Generation (CKG) for asymmetric keys as per SP800-133 (vendor affirmed).

The module does not support manual key entry or intermediate key generation output. In addition, the module does not produce key output outside its physical boundary. The keys can be entered or output from the module in plaintext form via API parameters, to and from the calling application only.

8.3 Key/CSP Storage

Public and private keys are provided to the Module by the calling process, and are destroyed when released by the appropriate API function calls. The Module does not perform persistent storage of keys.

8.4 Key/CSP Zeroization

The application is responsible for calling the appropriate destruction functions from the OpenSSL API. The destruction functions then overwrite the memory occupied by keys with zeros and deallocates the memory with the free() call. In case of abnormal termination, or swap in/out of a physical memory page of a process, the keys in physical memory are overwritten by the Linux kernel before the physical memory is allocated to another process.

8.5 Key Establishment

The module provides Diffie-Hellman and EC Diffie-Hellman key agreement schemes. These key agreement schemes are also used as part of the TLS protocol key exchange. The module also provides AES and RSA key wrapping. RSA key wrapping is also used as part of the TLS protocol key exchange.

The AES key wrapping provides between 128 and 256 bits of encryption strength. The security strength for RSA, Diffie-Hellman and EC Diffie-Hellman key agreement schemes is listed in Table 3.

9. Self-Tests

FIPS 140-2 requires that the Module performs self-tests to ensure the integrity of the Module, and the correctness of the cryptographic functionality at start up. In addition, conditional tests are required during operational stage of the module. All of these tests are listed and described in this section. See section 10.3 for descriptions of possible self-test errors and recovery procedure.

9.1 Power-Up Self-Tests

The Module performs power-up self-tests automatically during loading of the module by making use of default entry point (DEP) and no operator intervention is required. The module is not available for use until successful completion of power-up self-tests. Hence input, output, or any cryptographic functions cannot be performed while the Module is executing self-tests. The integrity of the module binary is verified using a HMAC SHA-256. The HMAC value is computed at build time and stored in the hmac file. The value is recalculated at runtime and compared against the stored value. If the comparison succeeds, then the remaining power-up self-test (consisting of the algorithm-specific Known Answer Tests) are performed. On successful completion of the power-up tests, the module becomes operational and crypto services are available. If any of the tests fails module transitions to error state and subsequent calls to the Module will fail - thus no further cryptographic operations will be possible.

Algorithm	Test
AES	KAT, encryption and decryption are tested separately.
Triple-DES	KAT, encryption and decryption are tested separately.
DSA	PCT, sign and verify.
RSA	KAT, signature generation and verification are tested separately.
ECDSA	PCT, sign and verify
Diffie-Hellman	Primitive "Z" Computation KAT
EC Diffie-Hellman	Primitive "Z" Computation KAT
SP 800-90A CTR_DRBG	KAT
SP 800-90A Hash_DRBG	KAT
SP 800-90A HMAC_DRBG	KAT
HMAC	(SHA-1, SHA-224, SHA-256, SHA-384, SHA-512) KAT
SHA	(1, 256, 512) KAT
CMAC	KAT
Module Integrity	HMAC-SHA-256

Table 11: Power-On Self-Tests

9.2 Conditional Self-Tests

Conditional tests are performed during operational state of the module when the respective crypto functions are used. If any of the conditional tests fails, module transitions to error state.

Algorithm	Test
DSA Key generation	Pairwise Consistency Test: signature generation and verification
ECDSA Key generation	Pairwise Consistency Test: signature generation and verification
RSA Key generation	Pairwise Consistency Test: signature generation and verification, encryption and decryption
DRBG NIST SP 800-90A	Continuous Random Number Generator Test

Table 12: Conditional Self-Tests

9.3 On-Demand self-tests

The module provides the Self-Test service to perform self-tests on demand. On demand self-tests can be invoked by powering-off and reloading the module. This service performs the same cryptographic algorithm tests executed during power-up. During the execution of the on-demand self-tests, crypto services are not available and no data output or input is possible

10. Crypto-Officer and User Guidance

This section provides guidance for the Cryptographic Officer and the User to maintain proper use of the module per FIPS 140-2 requirements.

10.1 Crypto-Officer Guidance

The RPM files containing the FIPS validated OpenSSL Module referenced in section 3 must be installed according to this guidance.

For proper operation of the in-module integrity verification, the prelink has to be disabled. This can be done by setting `PRELINKING=no` in the `/etc/sysconfig/prelink` configuration file. If the libraries were already prelinked, the prelink should be undone on all the system files using the `'prelink -u -a'` command.

To configure the operating environment to support FIPS perform the following steps:

1. Install the dracut-fips package:
yum install dracut-fips
2. Recreate the INITRAMFS image:
dracut -f

After regenerating the `initramfs`, the Crypto Officer has to append the following string to the kernel command line by changing the setting in the boot loader:

```
fips=1
```

If `/boot` or `/boot/efi` resides on a separate partition, the kernel parameter `boot=<partition of /boot or /boot/efi>` must be supplied. The partition can be identified with the command:

```
"df /boot"
```

or

```
"df /boot/efi"
```

For example:

```
$ df /boot
```

<u>Filesystem</u>	<u>1K-blocks</u>	<u>Used</u>	<u>Available</u>	<u>Use%</u>	<u>Mounted on</u>
/dev/sda1	233191	30454	190296	14%	/boot

The partition of `/boot` is located on `/dev/sda1` in this example. Therefore, the following string needs to be appended to the kernel command line:

```
"boot=/dev/sda1"
```

Reboot to apply these settings. After the reboot the file `/proc/sys/crypto/fips_enabled` will contain 1. If the file does not exist or does not contain "1", the operating environment is not configured to support FIPS and the module will not operate as a FIPS validated module.

After performing the above configuration, the Crypto Officer should proceed for module installation. The RPM package of the Module can be installed by standard tools recommended for the installation of Oracle packages on an Oracle Linux system (for example, yum, RPM, and the RHN remote management tool). The integrity of the RPM is automatically verified during the installation of the Module and the Crypto Officer shall not install the RPM file if the Oracle Linux Yum Server indicates an integrity error. The RPM files listed in section 3 are signed by Oracle and

during installation; Yum performs signature verification which ensures a secure delivery of the cryptographic module. If the RPM packages are downloaded manually, then the CO should run 'rpm -K <rpm-file-name>' command after importing the builder's GPG key to verify the package signature. In addition, the CO can also verify the hash of the RPM package to confirm a proper download.

10.2 User Guidance

In order to run the module in FIPS mode, only the FIPS approved or allowed services listed in table 8 or the validated or allowed cryptographic algorithms/security functions listed in Table 2 and 3 should be used. The function calls FIPS_mode_set(0), ENGINE_register_* and ENGINE_set_default_* are prohibited while running the module.

10.2.1 TLS and Diffie-Hellman

The TLS protocol implementation provides both, the server and the client sides. As required by SP800-131A, Diffie-Hellman with keys smaller than 2048 bits must not be used any longer. The TLS protocol lacks the support to negotiate the used Diffie-Hellman key sizes. To ensure full support for all TLS protocol versions, the TLS client implementation of the cryptographic Module accepts Diffie-Hellman key sizes smaller than 2048 bits offered by the TLS server.

The TLS server implementation of the cryptographic Module allows the application to set the Diffie-Hellman key size. The server side must always set the DH parameters with the API call of SSL_CTX_set_tmp_dh(ctx, dh)

For complying with the requirement to not allow Diffie-Hellman key sizes smaller than 2048 bits, the Crypto Officer must ensure that:

- in case the Module are used as TLS server, the Diffie-Hellman parameters (dh argument) of the aforementioned API call must be 2048 bits or larger;
- in case the Module are used as TLS client, the TLS server must be configured to only offer Diffie-Hellman keys of 2048 bits or larger.

10.2.2 Random Number Generator

The OpenSSL API call of RAND_cleanup must not be used. This call will clean up the internal DRBG state. This call also replaces the DRBG instance with the non-FIPS Approved SSLeay Deterministic Random Number Generator when using the RAND_* API calls.

10.2.3 AES GCM IV

In case the Modules' power is lost and then restored, the key used for the AES GCM encryption/decryption shall be re-distributed. The AES GCM IV generation is in compliance with the [RFC5288] and shall be used for the TLS protocol version 1.2 to be compliant with [FIPS IG] IG A.5, scenario 1.

10.2.4 Triple-DES Keys

According to IG A.13, the same Triple-DES key shall not be used to encrypt more than 2²⁸ 64-bit blocks of data.

10.3 Handling Self-Test Errors

The Module transition to error state when any of self-tests or conditional tests fails. The application must be restarted to recover from these errors. Following are the error messages specific to self-test failure:

FIPS_R_FINGERPRINT_DOES_NOT_MATCH – The integrity verification check failed

FIPS_R_SELFTEST_FAILED – a known answer test failed

FIPS_R_TEST_FAILURE – a known answer test failed (RSA); pairwise consistency test failed (DSA)

FIPS_R_PAIRWISE_TEST_FAILED – a pairwise consistency test failed during EC/DSA or RSA key generation

FIPS_R_DRBG_STUCK – the DRBG generated two same consecutive values



These errors are reported through the regular ERR interface of the Module and can be queried by functions such as `ERR_get_error()`. See the OpenSSL manual page for the function description.

When the Module is in error state, output is inhibited and no crypto operations are available. Any calls to the crypto functions in error state will return error message: 'FATAL FIPS SELFTEST FAILURE' on `stderr` and the application is terminated with the `abort()` call.

The only way to recover from the error state is to reload the module and restart the application. If failures persist, the Module must be reinstalled.

11. Mitigation of Other Attacks

RSA is vulnerable to timing attacks. In a setup where attackers can measure the time of RSA decryption or signature operations, blinding must be used to protect the RSA operation from that attack. The API function of `RSA_blinding_on` turns blinding on for key `rsa` and generates a random blinding factor. The random number generator must be seeded prior to calling `RSA_blinding_on`. Weak Triple-DES keys are detected as follows:

```

/* Weak and semi weak keys as taken from
 * %A D.W. Davies
 * %A W.L. Price
 * %T Security for Computer Networks
 * %I John Wiley & Sons
 * %D 1984
 * Many thanks to smb@ulysses.att.com (Steven Bellovin) for the reference
 * (and actual cblock values).
 */
#define NUM_WEAK_KEY 16
static const DES_cblock weak_keys[NUM_WEAK_KEY]={
/* weak keys */
{0x01,0x01,0x01,0x01,0x01,0x01,0x01,0x01},
{0xFE,0xFE,0xFE,0xFE,0xFE,0xFE,0xFE,0xFE},
{0x1F,0x1F,0x1F,0x1F,0x0E,0x0E,0x0E,0x0E},
{0xE0,0xE0,0xE0,0xE0,0xF1,0xF1,0xF1,0xF1},
/* semi-weak keys */
{0x01,0xFE,0x01,0xFE,0x01,0xFE,0x01,0xFE},
{0xFE,0x01,0xFE,0x01,0xFE,0x01,0xFE,0x01},
{0x1F,0xE0,0x1F,0xE0,0x0E,0xF1,0x0E,0xF1},
{0xE0,0x1F,0xE0,0x1F,0xF1,0x0E,0xF1,0x0E},
{0x01,0xE0,0x01,0xE0,0x01,0xF1,0x01,0xF1},
{0xE0,0x01,0xE0,0x01,0xF1,0x01,0xF1,0x01},
{0x1F,0xFE,0x1F,0xFE,0x0E,0xFE,0x0E,0xFE},
{0xFE,0x1F,0xFE,0x1F,0xFE,0x0E,0xFE,0x0E},
{0x01,0x1F,0x01,0x1F,0x01,0x0E,0x01,0x0E},
{0x1F,0x01,0x1F,0x01,0x0E,0x01,0x0E,0x01},
{0xE0,0xFE,0xE0,0xFE,0xF1,0xFE,0xF1,0xFE},
{0xFE,0xE0,0xFE,0xE0,0xFE,0xF1,0xFE,0xF1}};

```

Please note that there is no weak key detection by default. The caller can explicitly set the `DES_check_key` to 1 or call `DES_check_key_parity()` and/or `DES_is_weak_key()` functions on its own.

Acronyms, Terms and Abbreviations

Term	Definition
AES	Advanced Encryption Standard
AVX	Advanced Vector Extensions
CAVP	Cryptographic Algorithm Validation Program
CMVP	Cryptographic Module Validation Program
CSE	Communications Security Establishment
CSP	Critical Security Parameter
DH	Diffie-Hellman
DHE	Diffie-Hellman Ephemeral
DRBG	Deterministic Random Bit Generator
ECDH	Elliptic Curve Diffie-Hellman
ECDSA	Elliptic Curve Digital Signature Algorithm
EDC	Error Detection Code
HMAC	(Keyed) Hash Message Authentication Code
IKE	Internet Key Exchange
KAT	Known Answer Test
KDF	Key Derivation Function
NDRNG	Non-Deterministic Random Number generator
NIST	National Institute of Standards and Technology
PAA	Processor Algorithm Acceleration
POST	Power On Self Test
PR	Prediction Resistance
PSS	Probabilistic Signature Scheme
PUB	Publication
SHA	Secure Hash Algorithm
SSSE3	Supplemental Streaming SIMD Extensions 3
VPAES	AES with Vector Permutations
TLS	Transport Layer Security

Table 13: Acronyms

References

The FIPS 140-2 standard, and information on the CMVP, can be found at <http://csrc.nist.gov/groups/STM/cmvp/index.html>. More information describing the module can be found on the Oracle web site at www.oracle.com.

This Security Policy contains non-proprietary information. All other documentation submitted for FIPS 140-2 conformance testing and validation is “Oracle - Proprietary” and is releasable only under appropriate non-disclosure agreements.

Document	Author	Title
FIPS PUB 140-2	NIST	FIPS PUB 140-2: Security Requirements for Cryptographic Modules
FIPS IG	NIST	Implementation Guidance for FIPS PUB 140-2 and the Cryptographic Module Validation Program
FIPS PUB 140-2 Annex A	NIST	FIPS 140-2 Annex A: Approved Security Functions
FIPS PUB 140-2 Annex B	NIST	FIPS 140-2 Annex B: Approved Protection Profiles
FIPS PUB 140-2 Annex C	NIST	FIPS 140-2 Annex C: Approved Random Number Generators
FIPS PUB 140-2 Annex D	NIST	FIPS 140-2 Annex D: Approved Key Establishment Techniques
DTR for FIPS PUB 140-2	NIST	Derived Test Requirements (DTR) for FIPS PUB 140-2, Security Requirements for Cryptographic Modules
NIST SP 800-67	NIST	Recommendation for the Triple Data Encryption Algorithm TDEA Block Cipher
FIPS PUB 197	NIST	Advanced Encryption Standard
FIPS PUB 198-1	NIST	The Keyed Hash Message Authentication Code (HMAC)
FIPS PUB 186-4	NIST	Digital Signature Standard (DSS)
FIPS PUB 180-4	NIST	Secure Hash Standard (SHS)
NIST SP 800-131A	NIST	Recommendation for the Transitioning of Cryptographic Algorithms and Key Sizes
PKCS#1	RSA Laboratories	PKCS#1 v2.1: RSA Cryptographic Standard
RFC 5288	https://tools.ietf.org/html/rfc5288	AES Galois Counter Mode (GCM) Cipher Suites for TLS

Table 14: References